

E²T QUASAR 2 Flare Monitors
M8100-EXP • M8100-EXP Advanced



MANUAL

Confidential Information

The material contained herein consists of information that is the property of LumaSense Technologies, an Advanced Energy Company, and intended solely for use by the purchaser of the equipment described in this manual.

All specifications are subject to change without notice. Changes are made periodically to the information in this publication, and these changes will be incorporated in new editions.

LumaSense Technologies prohibits the duplication of any portion of this manual or the use thereof for any purpose other than the operation or maintenance of the equipment described in this manual, without the express written permission of LumaSense Technologies or Advanced Energy Industries, Inc.

Any unauthorized use of this manual or its contents is strictly prohibited.

Copyright

© 2018 LumaSense Technologies, Inc. All Rights Reserved. LumaSense Technologies, Inc., a subsidiary of Advanced Energy Industries, Inc.

Trademarks

E²T is a trademark of LumaSense Technologies.

All other trademarks are trademarks, registered trademarks, and/or service marks of their respective holders.

Service Centers

LumaSense Technologies, Inc.

North America

Sales & Service

3301 Leonard Court
Santa Clara, CA, 95054
Ph: +1 800 631 0176
Ph: +1 408 727 1600
Fax: +1 408 727 1677

LumaSense Sensor GmbH

Other Than North America

Sales & Support

Lübecker Straße 53-63
39124 Magdeburg
Germany
Ph: +49 (0) 391 544183 0

Global and Regional Centers

Our Headquarters

LumaSense Technologies, Inc.
Santa Clara, CA, USA
Ph: +1 800 631 0176
Fax: +1 408 727 1677

Americas, Australia, & Other Asia

LumaSense Technologies, Inc.
Santa Clara, CA, USA
Ph: +1 800 631 0176
Fax: +1 408 727 1677

Europe, Middle East, Africa

LumaSense Technologies GmbH
Frankfurt, Germany
Ph: +49 (0) 69 97373 0
Fax: +49 (0) 69 97373 167

France

LumaSense Technologies Sarl
Erstein, France
Ph: +33 3 8898 9801
Fax: +33 3 8898 9732

India

LumaSense Technologies, India
Mumbai, India
Ph: + 91 22 67419203
Fax: + 91 22 67419201

China

LumaSense Technologies, China
Shanghai, China
Ph: +86 133 1182 7766
Ph: +86 21 5899 7915

E-mail info@lumasenseinc.com
 support@lumasenseinc.com
 eusupport@lumasenseinc.com

Website <http://www.lumasenseinc.com>

Part No 3 915 091-EN
Rev. B
November 2018

Contents

1	General	11
1.1	Information about the user manual	11
1.1.1	Legend	11
1.1.2	Terminology	11
1.2	Safety	11
1.2.1	Explosion Proof Housing	12
1.3	Limit of Liability and Warranty	12
1.4	Unpacking and Inspection	13
1.5	Service Request, Repair, or Support	13
1.6	Shipments to LumaSense for Repair	14
1.7	Disposal / Decommissioning	14
2	Introduction	15
2.1	System Overview	15
2.2	System Features	16
2.3	Principle of Operation	16
2.3.1	Alarm Setpoint	17
2.3.2	Relay Contacts	17
2.4	Signal Path	17
2.5	Quick Installation Procedure	17
3	Mechanical Installation	21
3.1	Getting Started	21
3.2	Sight Assessment	21
3.2.1	Mounting Options	22
3.3	Ambient Temperature Limits	22
3.4	Viewport Air Purge Requirements	22
3.5	Target Size and Focusing Range	23
4	Electrical Installation	25
4.1	Electrical Installation Guidelines	25
4.1.1	Specific Conditions of Use	25
4.1.2	Conduit/Connections	25
4.1.3	Over-Current Protection/Service Switch	25
4.2	Power Connections	26
4.2.1	Service Markings	26
4.2.2	Protective Ground Connection	26
4.2.3	Cover Attachment	26
4.2.4	Powering with 24 Volts DC	27
4.2.5	Powering with 115 Volts AC	27
4.2.6	Powering with 220/230 Volts AC	27
4.3	Fusing	28
4.3.1	Mains	28
4.4	Connection for mA Output	28
4.4.1	Connection for switching mA Output	28
4.4.2	Connection for continuous mA Output ~ (Advanced Model Only)	28

4.5	Connecting the Setpoint Relay	28
5	Operating the QUASAR 2 M8100-EXP	29
5.1	Start-Up Operation Checklist, Pilot Monitor (PM)	31
5.1.1	Getting Started	31
5.1.2	Initial Control Settings.....	31
5.1.3	Delay and Decay Setting	31
5.1.4	System Gain/Climate Compensation.....	31
5.1.5	LED Indicators	32
5.1.6	Relay Contacts.....	32
5.1.7	Milliamp Output (+mA / -mA).....	32
6	Troubleshooting	33
6.1	Problem Isolation Checkout Procedure	33
6.1.1	Sight Path and Optical Alignment.....	33
6.1.2	Power Input.....	33
6.1.3	Power Fuse	33
6.1.4	Instrument Loops	33
7	Maintenance	35
7.1	General Maintenance	35
7.2	Cleaning the Optics	35
8	Safety Assurances and Precautions	37
8.1	Hazardous Environment Safety.....	37
8.1.1	Specific Conditions of Use (ATEX & IECEx).....	37
8.1.2	Specific Conditions of Use (USA & Canada)	38
8.2	Electrical Service Protection	38
8.2.1	Over-Current Protection / Service Switch	38
8.2.2	Protective Ground Connection	38
9	Specifications	39
9.1	Specifications	39
9.2	Reference Numbers	40
	Appendix A: Area Classification/Protection Concepts	43
	Declaration of Conformity/Certificates	43
	Appendix B: Engineering Drawings	57
	Index	63

1 General

1.1 Information about the user manual

This manual provides important information that can be used as a work of reference for installing, operating, maintaining, aligning, and/or troubleshooting your LumaSense Instrument. It is important that you carefully read the information contained in this manual and follow all safety procedures before you install or operate the system. To avoid handling errors, keep this manual in a location where it will be readily accessible.

1.1.1 Legend

 **Note:** Indicates tips and useful information in this manual. All notes should be read to effectively operate the instrument.

 **Caution:** Denotes information critical to avoiding instrument damage or a severe impact to processing. **When this symbol is found on the instrument it indicates a potential hazard. Consult the documentation before proceeding with any actions.**

 **Warning:** Denotes information critical to avoiding personal injury, such as when an electrical hazard is present. **When this symbol is found on the instrument it indicates a potential hazard. Consult the documentation before proceeding with any actions).**

 Protective Earth Ground connection.

 **Caution Must be Followed:** reference supplied documents.

 **Electric Shock Hazard:** disconnect service before opening.

 Voltage Alternating current (VAC).

 Voltage Direct Current (VDC).

1.1.2 Terminology

The terminology used in this manual corresponds to the VDI- / VDE-directives 3511, Part 4.

1.2 Safety

This manual provides important information on safely installing and operating your LumaSense Instrument. Several sections of this manual provide safety warnings to avert danger. These safety warnings are specified with a warning symbol. You must read and understand the contents of this manual before operating the instrument even if you have used similar instruments or have already been trained by the manufacturer.

It is also important to continually pay attention to all labels and markings on the instrument and to keep the labels and markings in a permanent readable condition.

See Chapter 8 Safety Assurances and Precautions for more information.

1.2.1 Explosion Proof Housing

The housing is designed to meet the explosion-proof requirements of the National Fire Protection Association (NFPA) Article 500 for hazardous locations.

To ensure safe operating conditions, it is recommended that you review the certification and area classifications that pertain to this system:

Reference

- Appendix A, Area Classification/Protection Concepts



Warning: Service personnel shall be qualified to install and service electrical equipment designed for areas classified as hazardous. At no time should the cover be removed unless power is switched off first. When it is necessary to service the instrument with the power applied, ensure proper safe environmental conditions exist and that such maintenance is authorized and pursuant to safe conditions.

See Chapter 8, Safety Assurances and Precautions, for more information.

1.3 Limit of Liability and Warranty

All general information and notes for handling, maintenance and cleaning of this instrument are offered according to the best of our knowledge and experience.

LumaSense Technologies is not liable for any damages that arise from the use of any examples or processes mentioned in this manual or in case the content of this document should be incomplete or incorrect. LumaSense Technologies reserves the right to revise this document and to make changes from time to time in the content hereof without obligation to notify any person or persons of such revisions or changes.

All instruments from LumaSense Technologies have a regionally effective warranty period. Please check our website at <http://info.lumasenseinc.com/warranty> for up-to-date warranty information. This warranty covers manufacturing defects and faults, which arise during operation, only if they are the result of defects caused by LumaSense Technologies.

1.4 Unpacking and Inspection

Before unpacking the instrument, locate the packing invoice on the outside of the carton. The invoice lists every item that was included in your shipment. Each LumaSense QUASAR 2 M8100-EXP instrument is configured to the default settings (Refer to Chapter 9, for a complete list). After you have installed the instrument and reviewed the contents of this manual, you will need to configure the instrument to match your application.

When unpacking and inspecting your system, you need to do the following:

- Check all materials in the container against the enclosed packing list.
- LumaSense Technologies cannot be responsible for shortages against the packing list unless a claim is immediately filed with the carrier. The customer must complete final claim and negotiations with the carrier.
- Carefully unpack and inspect all components for visible damage.
- Save all packing materials, including the carrier's identification codes, until you have inspected all components and find that there is no obvious or hidden damage.
- Before shipment, each instrument is assembled, calibrated, and tested at the LumaSense Factory. If you note any damage or suspect damage, immediately contact the carrier and LumaSense Technologies, Inc.

Once you have determined the unit you received is the unit you ordered and it is in acceptable condition, the unit is ready for installation. Be sure to reference Chapter 8, Safety Assurances and Precautions, before you begin installation

1.5 Service Request, Repair, or Support

Contact LumaSense Technologies Technical Support in case of a malfunction or service request. Provide clearly stated details of the problem as well as the instrument model number and serial number. Upon receipt of this information, Technical Support will attempt to locate the fault and, if possible, solve the problem over the telephone.

If Technical Support concludes that the instrument must be returned to LumaSense Technologies for repair, they will issue a Return Material Authorization (RMA) number.

Return the instrument upon receipt of the RMA number, transportation prepaid. Clearly indicate the assigned RMA number on the shipping package exterior. Refer to Section 1.6, Shipments to LumaSense for Repair, for shipping instructions.

Technical Support can be contacted by telephone or email:

Santa Clara, California (U.S., Mexico, and Canada)

- Telephone (408) 727-1600 or 1-800-631-0176
- Email support@lumasenseinc.com

Frankfurt, Germany

- Telephone: +49 (0) 69 97373 0
- Email: eusupport@lumasenseinc.com

For customers requiring language assistance, please contact your local office or representative to facilitate support and repair.

1.6 Shipments to LumaSense for Repair

All RMA shipments of LumaSense Technologies instruments are to be prepaid and insured by way of preferred carrier. For overseas customers, ship units air-freight, priority one.

The instrument must be shipped in the original packing container or its equivalent. LumaSense Technologies is not responsible for freight damage to instruments that are improperly packed.

Contact us to obtain an RMA number (if Technical Support has not already assigned one). Clearly indicate the assigned RMA number on the shipping package exterior.

Customers in **North America** should send RMA Shipments to:

Santa Clara, California

LumaSense Technologies, Inc.
3301 Leonard Court
Santa Clara, CA 95054 USA
Telephone: 1-800-631-0176

Email: support@lumasenseinc.com

All other customers should send RMA Shipments to:

Magdeburg, Germany

LumaSense Sensor GmbH
Luebecker Strasse 53 - 63
39124 Magdeburg , Germany
Telephone: +49 (0) 391 544183 0

Email: eusupport@lumasenseinc.com

1.7 Disposal / Decommissioning



Inoperable QUASAR 2 instruments must be disposed of in compliance with local regulations for electro or electronic material.

2 Introduction

2.1 System Overview

The E²T QUASAR 2 instruments provide continuous monitoring and detection of pilot flame and flared gases from flares. Two models are available: QUASAR 2 M8100-EXP and QUASAR 2 M8100-EXP Advanced. The base system provides basic flare pilot monitoring capabilities. The advanced system includes an intensity mA output, which allows the programming of multiple Setpoints to indicate pilot flame detection and flaring status signals from the same unit.

The Setpoint feature of the advanced unit can also be used for staged flares and will provide feedback on the staged flare status. Additional add-on features are available for a configurable product to meet a wide range of client flare types, monitoring requirements and budget.

The heart of the LumaSense QUASAR 2 M8100-EXP Flare Monitoring System is the non-contact infrared Electro-Optical package, which can be removed from the explosion proof housing for repairs or replacement, while leaving all wiring and alignment of the system intact (see Figure 1).

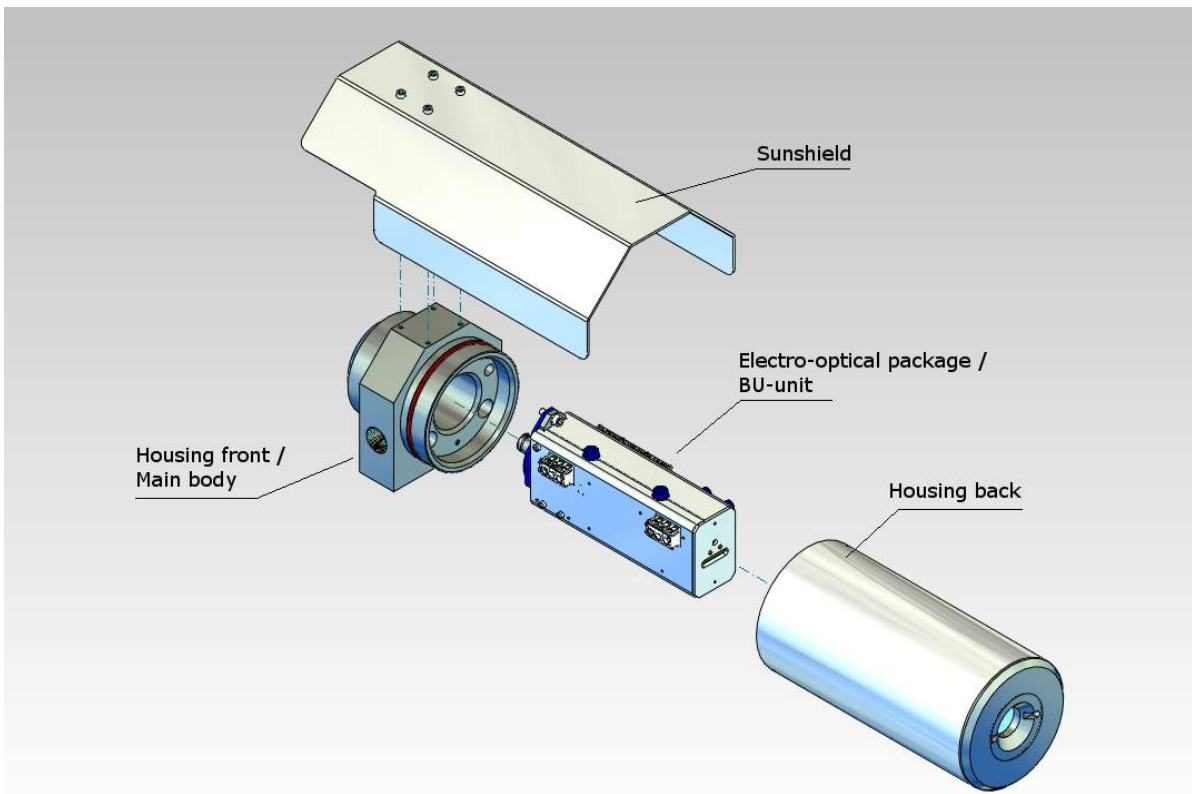

Figure 1: QUASAR 2 M8100-EXP Housing and Electro-Optical Package

A high-resolution optical system and selection of various spot sizes enables the QUASAR 2 to be positioned as far as 1/4 mile (400 m) from the stack being monitored. Alignment on the target is accomplished through the targeting port and signal intensity LED bar displays amplitude in combination with a stable M-4 heavy duty swivel mount.



Figure 2: QUASAR 2 M8100-EXP

Custom electronics adapt to target movement, varying luminosity, and most climate conditions. The alarm delay circuit can be adjusted for a specific location or application, eliminating false alarms from temporary loss of signal due to intermittent flames, adverse weather, and wind.

2.2 System Features

Features of the QUASAR 2 M8100-EXP Flare Monitoring System are as follows:

- Explosion-proof designed housing.
- Safety Integrity Level (SIL) 1, upgradeable to SIL 2 by combining two units.
- 4 or 20 mA switched output (4 mA = Flame and 20 mA = No Flame)
- Additional 4-20 mA continuous output for Pilot and flaring detection. Requires DCS mA Setpoint programming for low mA Setpoint for Pilot detection or high Setpoint for flaring. (Advanced model only).
- On-board ALARM Setpoint with normally open N.O. and normally closed N.C. relay outputs. This Alarm Setpoint can be adjusted from 2 seconds to 2 minutes delay.
- An Electro-Optical package that is easy to remove from the explosion-proof housing, minimizing downtime and increasing reliability (see Figure 1).
- LED signal intensity indicator bar
- Flame detection status indication lights.

2.3 Principle of Operation

All objects above absolute zero emit infrared energy. The amount of energy emitted is proportional to the body's temperature. The QUASAR 2 M8100-EXP collects this energy by means of a focusing optical system concentrating the energy from a body onto a sensitive infrared detector. Specialized amplification circuitry converts the signal received by the detector into a DC level to activate relay and mA outputs for monitoring. The QUASAR 2 M8100-EXP utilizes amplitude correction circuitry which, when initially set, will automatically correct for diminishing radiation amplitude due to varying and/or adverse weather conditions.

2.3.1 Alarm Setpoint

If the instrument detects a loss of signal fault, an adjustable delay timing circuit starts a countdown to activate a “loss of signal” alarm. This delay circuit allows for loss of signal due to wind or adverse conditions for a time period of two seconds to two minutes. This allows the monitor to reacquire the flame before an alarm signal is sent, limiting false alarms due to weather conditions. The alarm provides status by LED and Relay contacts.

2.3.2 Relay Contacts

Denoted by their non-energized states, Normal Open (N.O.) and Normal Closed (N.C.) contacts are common to a single Relay Common (Com), also known as “single pole double throw” contacts.

4-20mA Outputs

4 or 20mA circuit outputs 4mA or 20mA depending on a preset signal level. Standard output provides 4mA with a flame present, 20mA without a flame present. This is a switched output.

4-20mA Output (Advanced Model Only)

The QUASAR 2 M8100-EXP Advanced features an additional continuous analog output, whose signal is proportional to the flame intensity. By using DCS Setpoints, a low mA Setpoint can be programmed for pilot detection and a high-level mA Setpoint can be programmed for flaring. This method can also be used for staged flare applications by setting mA level Setpoints for the different flare stages.

2.4 Signal Path

Infrared (IR) energy is focused onto the detector via a high quality optical system. By virtue of select, application-specific IR filters, the desired IR energy is allowed to pass and be amplified by the detector. Filters are located on the detector.

The detector signal is further filtered and provides the input to subsequent; relay driver, time delay, status LEDs and 4-20mA output control circuits.

2.5 Quick Installation Procedure

This quick installation procedure may be used as a checklist if you are familiar with the equipment. For complete instruction and safety precautions, refer to the appropriate sections of this manual:

- Appendix B: Engineering Drawing App 1 and 2, Service Connections
- Chapter 3 Mechanical Installation
- Chapter 4 Electrical Installation
- Chapter 8 Safety Assurances and Precautions



Warning: Service personnel shall be qualified to install, and service electrical equipment designed for areas classified as hazardous. At no time should the cover be removed unless power is switched off first. When it is necessary to service the instrument with the power applied, ensure proper safe environmental conditions exist and that such maintenance is authorized and pursuant to safe conditions.

See Chapter 8 Safety Assurances and Precautions, for more information.

Connecting Power Supply

The Quasar 2 can be powered by either a voltage of 115 VAC, 230 VAC, or alternatively with a voltage of 24 VDC through the separate AC or DC power terminal strips. **Only one of the three power supply possibilities must be connected! Connection of more than one power source will damage the system.**

All electrical connections are made through terminal strips located on the terminal strips on the power input side of the housing (wire range 14 – 22 AWG (0.4mm² - 2mm²)). Connect wires as shown in Figure 3. Wires should be routed to the unit through the 3/4" NPT threaded conduit port located on the left side of the housing. Connect AC Power 115/230 VAC 50/60 Hz or DC Power 24 VDC, as indicated. The appropriate packing glands should be used per EXP requirements.

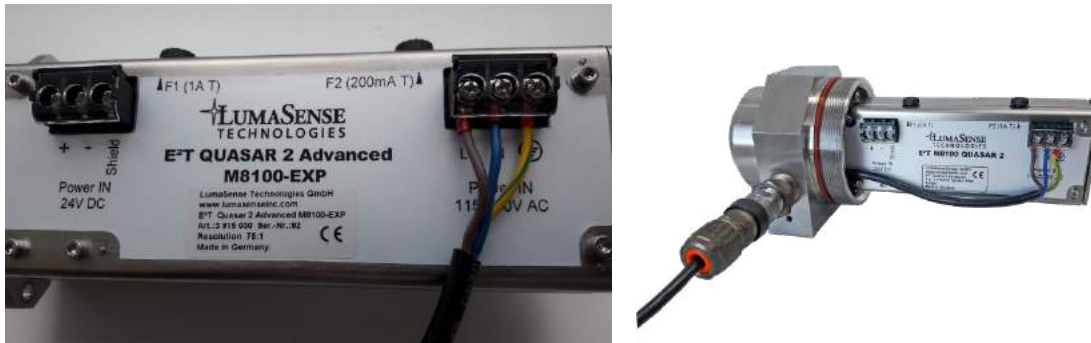

Figure 3: QUASAR 2/QUASAR 2 Advanced EIO-Package (left side view)

Connecting Alarm Signal Output and Instrumentation current outputs

All electrical connections are made through terminal strips located on the signal output side of the housing with the system adjustment knobs using (wire range 14 – 22 AWG (0.4mm² - 2mm²)). Wires should be routed to the unit through the 3/4" NPT threaded conduit port located on the right side of the housing. The appropriate packing glands should be used per EXP requirements.

Connect lines for the relay to the terminal as shown in Figure 4. Connect the 4-20 mA current output to the terminal for switched and/or continuous output as shown in Figure 4.

Positive mA to mA (+)
Negative mA to mA (-)

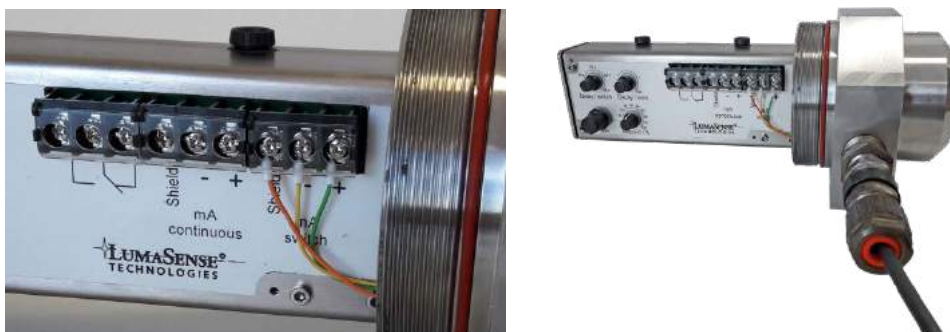

Figure 4: QUASAR 2 Advanced EIO-Package (Output side view).
The standard version is missing the continuous output, the rest is identical.

Installation / Start-up

1. Remove cover.
2. Aim the Quasar 2 properly on flame.
3. Connect power as described (See Fig. 3).
4. Initial Pot settings: (See Fig. 2)
5.
 - a. Setpoint pot set for approximately 50%
 - b. Gain Pot full clockwise
 - c. Delay Pot full counterclockwise
 - d. Decay Pot full counterclockwise
6. Gain adjustment



Align the Quasar on flare tip using the sighting port and adjust for maximum output on the intensity led bar.

The green "flame detect" LED should illuminate. If the intensity falls below Setpoint reading, the red "Flame off" LED should illuminate after the delay has timed out.



7. Delay setting for switched analog output.

Once the instrument is aimed at the pilot flame, adjust the Delay Pot full clockwise for maximum delay (approximately 2.0 minutes).

Adjust the Delay Pot full counterclockwise for minimum delay (approximately 2 seconds). Determine duration of delay by covering lens and measuring elapsed time until the red light illuminates. Most used delay time is 45 seconds to conform to governmental record requirements of recording pilot status every minute.

8. Decay setting for the continuous analog output
9. Adjust Decay Pot until getting a continuous output signal.
10. After adjustment check mA output 4 mA / 20 mA
11. Reattach cover

To ensure consistent document formatting, this page was intentionally left blank.

3 Mechanical Installation

3.1 Getting Started

Each LumaSense E²T QUASAR 2 M8100-EXP instrument is configured as per customer's request. The packing slip order number matches that of the instrument's serial number. It is recommended to confirm that the instrument's configuration meets expectation, by reviewing packing slip details.

Once you have determined the unit you received is the unit you ordered, and it is in acceptable condition, the unit is ready for installation. It would be a good idea to spend a few minutes "getting to know" your QUASAR 2 M8100-EXP.

Reference: Chapter 8 Safety Assurances and Precautions.

3.2 Sight Assessment

Care must be taken during installation to ensure that the sun will not be seen through the optical sight path in any season or time of day. This requires that the instrument be located on a true north-south axis $\pm 45^\circ$. In the northern hemisphere, the monitor preferably should be looking toward true north, while in the southern hemisphere it should be aimed toward true south. Contact LumaSense for exceptions to these standard installation parameters. A solar analysis can be made of your location to determine suns annual locations for your location.

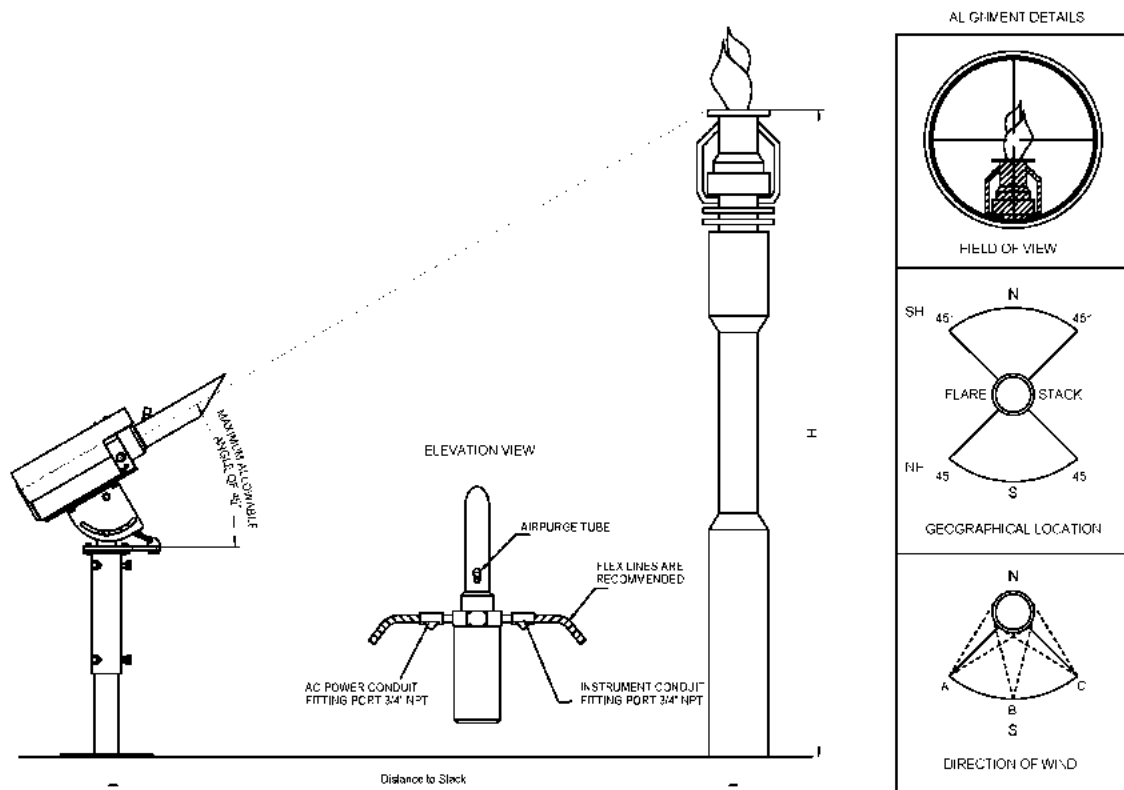

Figure 5: Installation Diagram

3.2.1 Mounting Options

For stable mounting, alignment, and focusing on the target, a heavy duty adjustable swivel mount Model M-4 with reliable position locking and adjusting capability is recommended for reliable performance and positive position locking of Quasar 2 on targeted flare tip. (LumaSense's M-4 Heavy Duty Swivel Mount).

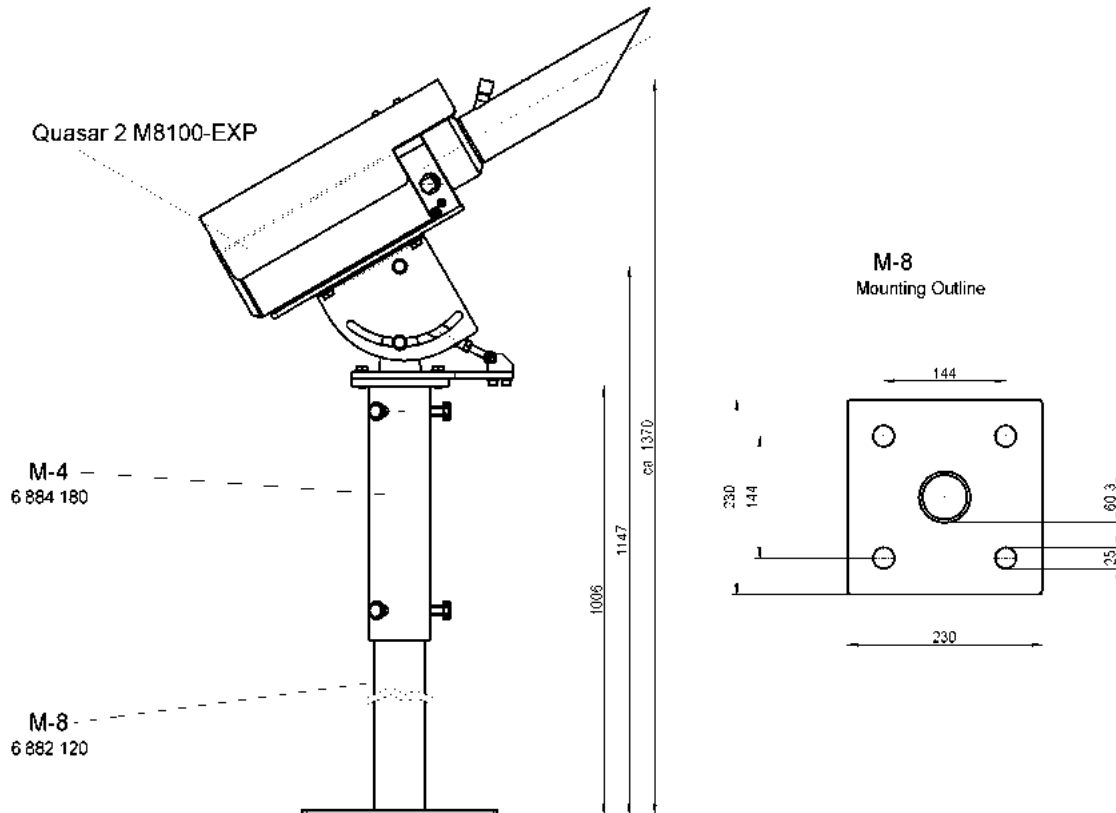

Figure 6: Pedestal Mounting Concept

The M-4 Heavy Duty Swivel Mount can be secured on a pedestal base model M-8 using a telescoping steel pipe with a bolt down plate to secure the M-8 to a foundation. (See Figure 6) As an alternative, the M-4 Heavy Duty Swivel Mount can be installed on a client supplied mount that provides a 2-inch schedule 40 pipe mount.

3.3 Ambient Temperature Limits

The ambient operating temperature limits of the QUASAR 2 M8100-EXP are -40 °F (-40 °C) to 140 °F (60 °C). If the ambient temperature is expected to be below -40 °F (-40 °C), additional thermal jacket protection for the instrument is required.

3.4 Viewport Air Purge Requirements

A source of sustained dry instrument air with a flow rate through a regulator or needle valve capable of sustaining 28l/min flow rate from a 1.4bar or greater supply is required to keep the lens clean. If air is not available, a preventative maintenance schedule should be created that allows for the front window of the system to be cleaned on a regular timeframe.

3.5 Target Size and Focusing Range

The target size of the QUASAR 2 M8100-EXP is a function of the distance from the lens to the object under observation and the optical resolution set at the factory. The target area is aligned using the targeting port to aim the system and led intensity bar for the highest signal amplitude. The systems target size is determined by distance to the target divided by the resolution.

$$\text{Target Size} = \frac{D}{R}$$

Resolution
37.5
75
100
150
300

Where D = the distance from the lens to the target
R = the appropriate value from the above table.

The resolution of the optics is application-specific and determined at time of order.

To ensure consistent document formatting, this page was intentionally left blank.

4 Electrical Installation

4.1 Electrical Installation Guidelines

Be sure to reference Appendix B Engineering Drawing App1 and App2, Service Connections during this procedure.

4.1.1 Specific Conditions of Use

1. Contact manufacturer for flame path joint design information.
2. The cable glands, cable sealing device or blanking plugs for the unused entries (as applicable) shall be suitably certified with a minimum Ex rating of Ex db IIB
Ta = -40 °C to 60 °C Gb.
3. In order to maintain an IP66 rating for the equipment, the cable glands shall be suitably certified with a minimum rating of IP66.
4. To reduce the risk due to electrostatic discharge, the user shall regularly clean the enclosures with a damp cloth to limit dust layers on the enclosure sides

4.1.2 Conduit/Connections

Power and signal wires are fed through the 3/4-inch NPT conduit holes in the side of the housing. All wires exiting the enclosure must run through properly installed explosion-proof packing gland fittings to maintain the explosion-proof rating. Only a qualified service person should perform operations on this instrument.



Warning: For



II 2 G, Ex db IIB T4 applications, this seal must be directly at the enclosure entry.

LumaSense does not provide the explosion-proof packing gland fittings required for installations since client standards vary as to the brand or type of explosion-proof packing gland fittings required for installations. Additionally, states and countries have different standards, making it very difficult for LumaSense to stock the proper fittings.

Flexible conduit of sufficient length must be used from the housing explosion-proof packing gland fittings to the hard conduit or junction box to enable movement of the unit on the pedestal.

All power and signal connections are made on infrared electro-optical package inside the explosion-proof enclosure. Power is connected to left side of the instrument. Output signals are connected to terminal on the right side of the instrument (See Figures 3 and 4).

See Chapter 8.2 Electrical Service Protection, for more information.

4.1.3 Over-Current Protection/Service Switch

It is necessary to incorporate an external over-current protection device appropriate to the instrument's service and to include a disconnect switch located near the instrument. The service disconnect should be clearly marked as pertaining to this instrument.

4.2 Power Connections

Connect the input power as described in this chapter. Confirm service type and check that the instrument service markings correspond to expectations. When wiring, follow local code regulations. Secure power input conductors together after connection to terminal blocks to prevent an accidental hazardous live condition in the event a terminal screw becomes loose. Sleeve or tie wrapping is acceptable. Check to ensure power is not accidentally connected to the 24VDC low voltage terminal block.

4.2.1 Service Markings

Input Power service (i.e. 115VAC, 230VAC, 24VDC) and Fusing type are factory set and marked on the Terminal Output PCB (See Figure 7).

4.2.2 Protective Ground Connection



Connect the protective Earth conductor to the terminal lug located inside the housing as indicated by the symbol.

4.2.3 Cover Attachment



Warning: At no time should the cover be removed, unless power is switched off first. When it is necessary to service the instrument with the power applied, ensure that proper safe environmental conditions exist and that such maintenance is authorized and pursuant to safe conditions.

Reference Chapter 8, Safety Assurances and Precautions, during this procedure.



Figure 7: Input Terminals of the E²T QUASAR 2 M8100-EXP.

Note: The standard model does only feature the 24VDC input.

4.2.4 Powering with 24 Volts DC



Note: Voltage/fusing are factory set. Use a wire gauge appropriate to service installation. See Chapter 9 for Power and Fuse Requirements and Appendix B, Service Connections, Drawing App1 and App2.

To connect 24VDC:

- +24Vdc to terminal labeled PowerIN 24VDC +
- 24V Return to terminal labeled PowerIN 24VDC -
- Ground to Safety Ground stud

4.2.5 Powering with 115 Volts AC



Note: Voltage/fusing are factory set. Use a wire gauge appropriate to service installation. See Chapter 9 for Power and Fuse Requirements and Appendix B, Service Connections, Drawing App1 and App2.

To connect 115 VAC to Terminal Power IN 115/230V AC:

- AC Hot to terminal labeled L1
- AC Neutral to terminal labeled N
- AC Ground to Safety Ground stud

4.2.6 Powering with 220/230 Volts AC



Note: Voltage/fusing are factory set. Use a wire gauge appropriate to service installation. See Chapter 9 for Power and Fuse Requirements and Appendix B, Service Connections, Drawing App1 and App2.

North American Connection, as follows:

- AC Hot1 to terminal labeled L1
- AC Hot2 to terminal labeled N
- AC Ground to Safety Ground stud

European Connection, as follows:

- AC L1 to terminal labeled L1
- AC N to terminal labeled N
- AC Ground to Safety Ground stud

4.3 Fusing

4.3.1 Mains

Two fuses, F1 and F2, can be accessed via the black fuse holders on top of the Electro-optical package. F1 is used for all power configurations.

- F2 is used only in 220/230VAC applications.



Note: Refer to Chapter 9 Specifications for fuse requirements. Also see Appendix B, Service Connections, Drawing App1 and App2.

4.4 Connection for mA Output

4.4.1 Connection for switching mA Output

The mA current loop is a self-powered output for recorders or controllers requiring current loop feedback. The QUASAR 2 M8100-EXP supplies its own 4-20mA current to a load. The 4-20mA output is isolated from the Power ground. Loads up to a maximum of 500 ohms may be connected in SERIES. Once connected, voltage measured between mA outputs and Chassis GND (common mode) should not to exceed 15VDC.

A shield is recommended, however do not connect the shield to the instrument's GND, connect it only to the Chassis GND.



Caution: Refer to Chapter 8 Safety Assurances and Precautions before connecting the 4-20mA loop to the terminal.

Connect the mA lines to the corresponding (mA-) and (mA+) switching output.

- Positive mA to mA+
- Negative mA to mA-

4.4.2 Connection for continuous mA Output ~ (Advanced Model Only)



Caution: Refer to Chapter 8 Safety Assurances and Precautions before connecting the 4-20mA loop to the terminal.

Connect the mA lines to the corresponding (mA-) and (mA+) continuous output.

- Positive mA to mA+
- Negative mA to mA-

4.5 Connecting the Setpoint Relay

The Setpoint relay provides a dry contact closure with a normally open and normally closed output. The relay is rated 1 amp resistive to 250 VAC max.

Connect the relay to terminal as follows:

- Relay COMMON to COM
- Relay NORMALLY OPEN to N.O.
- Relay NORMALLY CLOSED to N.C.

5 Operating the QUASAR 2 M8100-EXP

This section covers the start-up procedures for operating the **Flare Monitor**. After the unit has been installed in accordance with Chapters 3 and 4. To provide insight into the logic behind the procedure, some background on the field operation of the instrument is provided.

The Flare Monitor is designed to continuously monitor the presence of a pilot flame under varied environmental and changing weather conditions. It reports the presence of a pilot flame via the switched mA output with a 4mA or 20mA current output; low current signal 4mA when Flame is detected, and high level 20mA current (alarm) when No Flame is detected. An additional relay switch is triggered for No Flame alarm. Both the mA and Relay status is subject to the delay setting of the system.

Setup of the Flare Monitor for pilot detection for the best performance during adverse weather conditions (cloudy/windy) is achieved by setting system to its highest gain. The delay setting should be set for 45 sec or higher to reduce or eliminate false alarms during windy conditions. Most governmental recording requirements require a record of pilot status every minute. A delay setting of 45 sec will allow for the system update prior to the 1 min recording while limiting false alarms being sent to the control room.

Field experience has proven that dense fog, heavy snow, and severe sandstorms absorb infrared energy, so closer placement of the instrument may be necessary if setup cannot accommodate these conditions.



Note: Refer to Figure 8: Instrument Aiming Concepts and Figure 9: Opto-Electronics Module for the following start-up procedure.

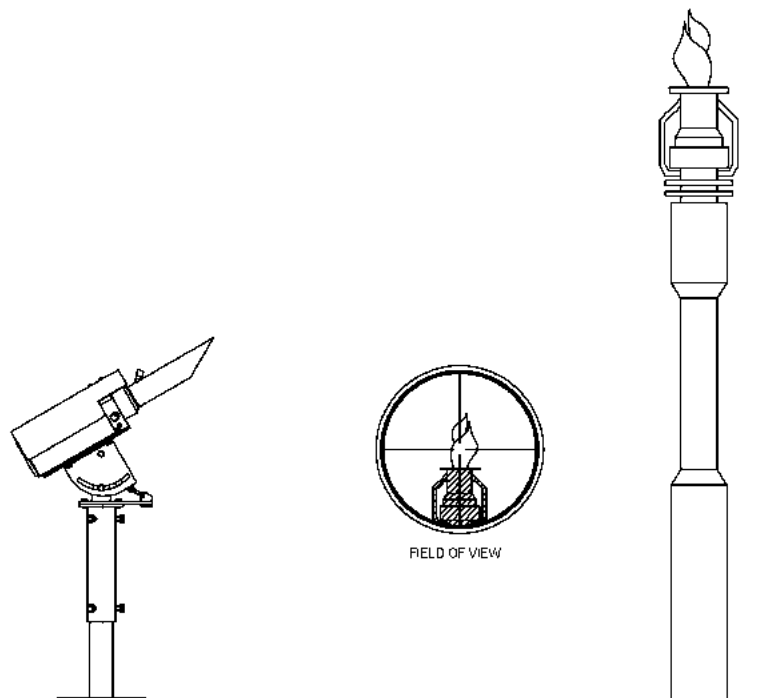

Figure 8: Instrument Aiming Concept

- 1) 24VDC Input
- 2) Fuses
- 3) 115/230 VAC Input
- 4) Delay Setting (switched output only)
- 5) Decay Setting (continuous output only)
- 6) Relay Outputs
- 7) Continuous Output
- 8) Switched Output
- 9) Amplifier Gain
- 10) Setpoint
- 11) Sight Through Optics
- 12) LED Indicator (on/off)
- 13) LED Intensity Bar

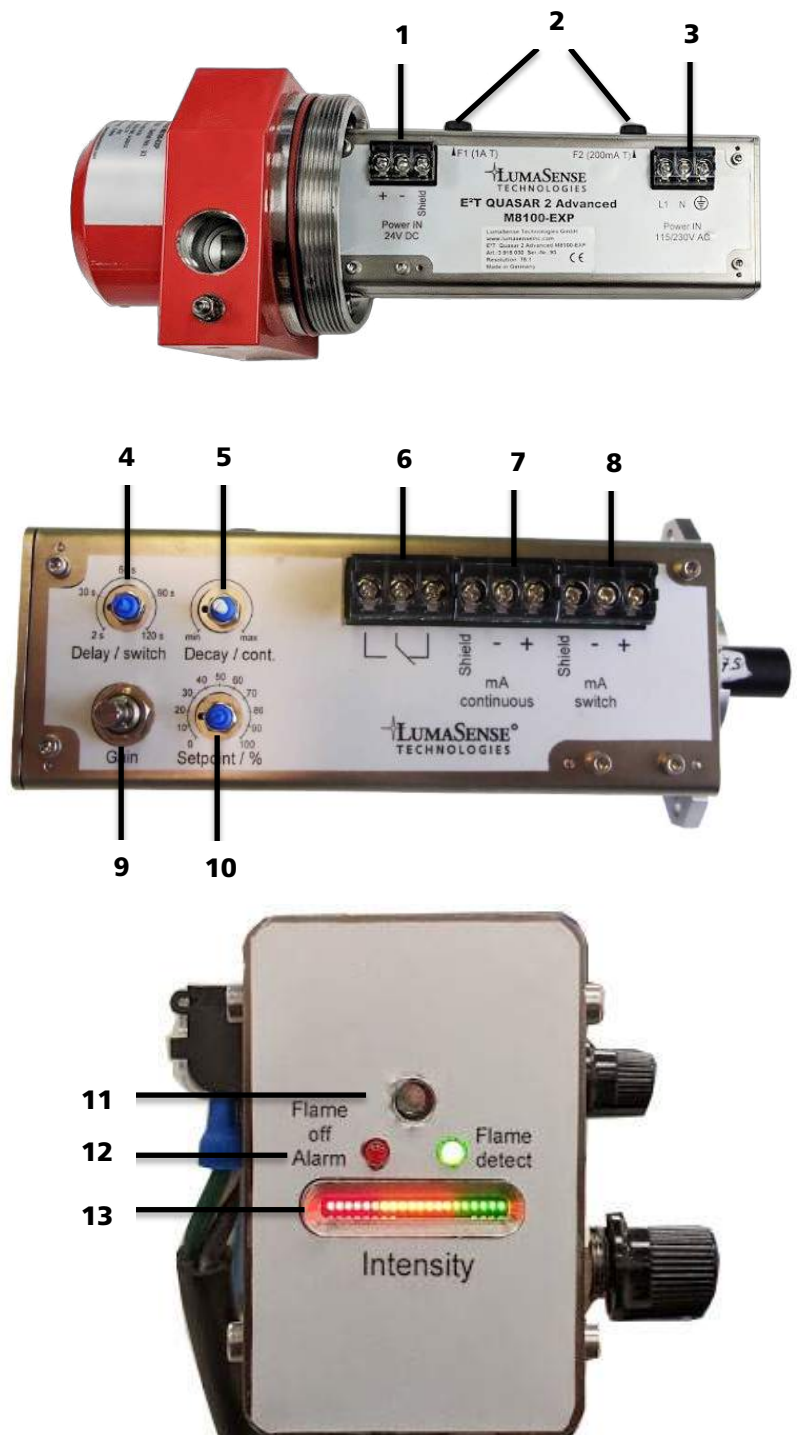

Figure 9: Opto-Electronics Module

5.1 Start-Up Operation Checklist, Pilot Monitor (PM)



Warning: At no time should the cover be removed unless the power is switch-off first. When it is necessary to service the instrument with the power applied, ensure that proper safe environmental conditions exist and that such maintenance is authorized and pursuant to safe conditions.

5.1.1 Getting Started

- Remove cover
 - Ensure that the sight path is clear.
 - Verify that the proper power and signal connections have been made as per Chapter 4, Electrical Installation.
-



Caution: Ensure that safe conditions exist before applying power to the instrument. Allow at least 30 minutes of warm-up time before proceeding.

5.1.2 Initial Control Settings

(Item numbers refer to Figure 9: Opto-Electronics Module)

- Set Setpoint pot (Item 10) to approximately 50%. Set pots (Items 4, 5) to full counterclockwise and (item 9) to full clockwise.

5.1.3 Delay and Decay Setting

The Delay/Decay setting postpones the Alarm condition once the Setpoint value is exceeded. This can prevent false alarms from varying conditions or wind.

- Delay setting for switched analog output
Once the instrument is aimed at the Flare tip adjust the Delay Pot (Item 4) full clockwise for maximum delay (approximately 2.0 minutes). Adjust the Delay Pot full counterclockwise for minimum delay (approximately 2 seconds). Determine duration of delay by covering lens and measuring elapsed time until the red light illuminates. 45 sec is recommended to comply with most governmental 1-minute recording intervals.
 - Decay setting for the continuous analog output (Advanced Model Only):
Adjust Decay Pot (Item 5) until getting a continuous output signal.
-



Note: Full clockwise for maximum delay (approximately 2.0 minutes). Full counterclockwise for minimum delay (approximately 2 seconds).

5.1.4 System Gain/Climate Compensation

Optimize these two gain settings by performing the following (See Figure 9, Opto-Electronics module):

- Adjust Gain Pot clockwise as far as possible. The green “flame detect” LED should illuminate. If the intensity falls below Setpoint reading, the red “Flame off” LED should illuminate after the delay has timed out.

5.1.5 LED Indicators

Red/Green LED Indicators:

When the analog meter reading falls below the Setpoint, the red LED "Flame Out Alarm" will light after the delay has timed out. The green LED will go out.

The LED intensity bar indicator will show flame signal level. A low indication will indicate pilots and high levels indicate flaring.

5.1.6 Relay Contacts

Check the relay contacts at the instrument's Terminal Output board. N.O. and N.C. contacts are both available simultaneously. Verify that the desired polarity is obtained during an alarm condition.



Note: Make note of the contact position when the instrument power is interrupted or shut-off. The relay is energized when the green LED is lit. It is not energized during an alarm or power loss.

5.1.7 Milliamp Output (+mA / -mA)

Switched mA output should be approximately 4mA when the flame is present, and the signal should read approximately 20mA when flame is lost. **Continuous mA output** should read low mA output when detecting pilots and high mA output when detecting flaring. The continuous mA signal can be used in the DCS to setup low-level mA Setpoint for pilot detection and higher mA Setpoint for flaring detection. This output can also provide the DCS system a mA level Setpoint for staged flare systems with a mA Setpoint for each of the flares stages.

Milliamp checks must be accomplished with a Milliamp meter placed in series with the control room loop or parallel across the mA+ and mA- terminals when no other connections are on the terminals.

6 Troubleshooting

6.1 Problem Isolation Checkout Procedure

This is an outline of what to do if the LumaSense QUASAR 2 M8100-EXP is not performing correctly after initial installation. Follow the procedures below to determine the problem. Do not hesitate to contact the factory for assistance. (Refer to Section 1.5 for more information.)



Warning: At no time should the cover be removed, unless the power is switch-off first. When it is necessary to service the instrument with the power applied, ensure that proper safe environmental conditions exist and that such maintenance is authorized and pursuant to safe conditions.

6.1.1 Sight Path and Optical Alignment

Ensure that the QUASAR 2 M8100-EXP is aligned properly by looking through the targeting port. The cross hairs in the center of the field of view should be sighted at the target. Look for any blockage in the sight path that would reduce the energy received by the QUASAR 2 M8100-EXP.

Without a clear optical path, the infrared energy from a target cannot reach the detector. If the lens becomes smeared, smudged, or otherwise dirty, excessive attenuation of the signal may occur.

The internal optics seldom becomes dirty with normal use. Rarely will cleaning of the internal optics be necessary.

6.1.2 Power Input

Look for status LED operation; if the electronics are powered properly, one of the LEDs will be lit.

Verify that the input power is connected properly and that the ratings correspond to the instrument's rating.

See Chapter 4, Electronic Installation, for details on connections and rating.

6.1.3 Power Fuse

If the Power input has been checked and neither LED is on, then there is a possibility of a blown Fuse(s). This can easily be checked by inspection. Fuses marked F1 and F2 (if equipped) are located on top of the Opto-Electronics module. Inspect and check for an open condition.

6.1.4 Instrument Loops

Check that the mA signal is being transmitted through the loop to the control room display. To verify the signal from the instrument, disconnect the mA control room loop wires from the analogue outputs and check the instrument's output using a standard mA meter.

To ensure consistent document formatting, this page was intentionally left blank.

7 Maintenance

7.1 General Maintenance

Refer to Chapter 8 Safety Assurances and Precautions, when performing the following procedures.



Warning: At no time should the cover be removed unless the power is switch-off first. When it is necessary to service the instrument with the power applied, ensure that proper safe environmental conditions exist and that such maintenance is authorized and pursuant to safe conditions.

Some internal electronic repairs may be performed on the LumaSense E²T QUASAR 2/QUASAR 2 Advanced M8100FM-EXP without requiring re-calibration to the factory standards, but many components are matched, and temperature compensated and cannot be replaced in the field without factory re-calibration.

7.2 Cleaning the Optics

The front window should be cleaned monthly. After removing the air purge tube, use facial tissue dipped in rubbing alcohol (isopropyl 70%) to clean the window.

The optical system of the QUASAR 2 M8100-EXP consists of a lens and a viewport. The optics of the QUASAR 2 M8100-EXP are located within the electro-optical package and will remain clean under normal conditions, provided the enclosure remains sealed at all times with O-rings in place. LumaSense does not recommend cleaning optics other than the external enclosure window.

To clean the external enclosure window, use facial tissue dipped in rubbing alcohol (Isopropyl 70%). If it is especially dirty, use a lens cleaning solution. Press softly or the lens may become loose or dislodged.

To ensure consistent document formatting, this page was intentionally left blank.

8 Safety Assurances and Precautions

8.1 Hazardous Environment Safety

The LumaSense QUASAR 2 M8100-EXP enclosure is designed to hold an explosion inside the housing and release the hot gases slowly enough to allow them to cool to the point where they will not ignite the explosive gases outside the housing. It is important to take care of the mating surfaces between the housing and its lid. It is also important to torque the lid bolts to specification.

Factory inspection, assembly, and test procedures are strictly followed to ensure the highest quality, integrity and functionality of the Explosion Proof housing. Use care when reassembling to maintain gasket and surface integrity. Deep scratches or gouges could allow gases to be released at excessively high temperatures during an explosion.

- When servicing the instrument, ensure that power is disconnected or switched off.
- When connecting electrical wiring to the circuit board, ensure wires are properly secured to prevent accidental shorting or a hazardous live condition in the event that screws loosen.
- Check and secure the Safety Ground connections just prior to lid closure.
- When attaching the utility conduit, ensure that at least five threads are engaged, and that appropriate seal fittings and practices are followed in accordance to local and manufacturer's Explosion Proof practices.
- When air is used, verify positive airflow and pressure to air connections.
- Ensure that the surface temperature of the Explosion Proof housing does not exceed 140 °F (60 °C).
- Take note of all hazardous classifications. See Appendix A, Area Classifications and Protection Concepts, for more information.

8.1.1 Specific Conditions of Use (ATEX & IECEx)

1. Contact manufacturer for flamepath joint design information.
2. The cable glands, cable sealing device or blanking plugs for the unused entries (as applicable) shall be suitably certified with a minimum Ex rating of Ex db IIB Ta = -40 °C to 60 °C Gb.
3. In order to maintain an IP66 rating for the equipment, the cable glands shall be suitably certified with a minimum rating of IP66.
4. To reduce the risk due to electrostatic discharge, the user shall regularly clean the enclosures with a damp cloth to limit dust layers on the enclosure sides.

8.1.2 Specific Conditions of Use (USA & Canada)

1. Contact manufacturer for flamepath joint design information.
2. The cable glands, cable sealing device or blanking plugs for the unused entries (as applicable) shall be suitably certified with a minimum rating of Class I, Division 1, Groups C & D for Division 1 wiring & Class 1, Division 2, Groups A, B, C & D for Division 2 wiring.
3. To reduce the risk due to electrostatic discharge, the user shall regularly clean the enclosures with a damp cloth to limit dust layers on the enclosure sides.

8.2 Electrical Service Protection

8.2.1 Over-Current Protection / Service Switch

It is necessary to incorporate an external over-current protection device appropriate to the instrument's service and to include a disconnect switch located near the instrument. The service disconnect should be clearly marked as pertaining to this instrument.



8.2.2 Protective Ground Connection



Connect the protective Earth conductor as instructed in Chapter 4, Electrical Installation. The Earth Ground connection is located on the inside surface of housing denoted by the symbol shown left.

9 Specifications

9.1 Specifications

Temperature Range	Designed for Flares/Pilots of any intensity						
Working Distance	0 - 1320 ft. (0 - 400m)						
Response Time	10 m Seconds						
Outputs	Green and Red status lights, mA and Setpoint relay contacts						
Relay Contacts	250Vac 1A , 24Vdc 1A , Resistive						
Sensitivity Adjustment	Automatic climate compensation and manual gain for easy system setup						
Focusing Range	20 in. (51cm) to infinity						
Sighting	Visual aiming						
Target Size (Field of View)	S (dia. of circle) = D (Distance)/37.5, 60, 75, 150, or 300						
Power Ratings	115/230V ~ ± 10%, 50/60 Hz 24VDC +/-20% 5 Watts						
Fusing	ELECTRONICS: 115/230VAC, 0.2A, 'T' Time-Lag 5x20 Little fuse type 0215.200XP 24VDC 1A, 'T' Time-Lag 5x20 Little fuse type 0477.001XP						
Ambient Temperature Limits	A. -40 to 140 °F (-40 to 60 °C) with no cooling and using internal heater.						
Hazard Classification (See Appendix B, Area Classifications / Protection Concepts.)	<p>Quasar 2:</p> <table border="1"> <tr> <td> <p>CAUTION: OPEN CIRCUIT BEFORE REMOVING COVER</p> <p>ATTENTION: OUVRIR LE CIRCUIT AVANT D'ENLEVER LA COUVERCLE</p> <p>WARNING – DO NOT OPEN WHEN AN EXPLOSIVE ATMOSPHERE MAY BE PRESENT</p> <p>AVERTISSEMENT– NE PAS OUVRIR SI UNE ATMOSPHERE EXPLOSIVE PEUT ÊTRE PRÉSENTE</p> </td> <td> <p>LUMASENSE TECHNOLOGIES EIT IR Pyrometer LumaSense Technologies GmbH 60326 Frankfurt</p> <p>QUASAR 2 M8100-EXP</p> <p>Ref. No.: ; Serial No.:</p> <p>CE 1725 Ex II 2G Ex db IIB T4 Gb</p> <p>FM18ATEX0036X ; FM18US0126X ; FM18CA0061X ; IECEX FME 18.0002X Class I, Div. 1, Groups C & D, T4 ; Class I, Div. 2, Groups A, B, C & D, T4 Ta = -40°C to 60°C IP66 TYPE 4X 24 VDC / 115 VAC / 230 VAC 5 Watts Made in Germany www.lumasenseinc.com</p> </td> <td>  </td> </tr> </table> <p>Quasar 2 Advanced:</p> <table border="1"> <tr> <td> <p>CAUTION: OPEN CIRCUIT BEFORE REMOVING COVER</p> <p>ATTENTION: OUVRIR LE CIRCUIT AVANT D'ENLEVER LA COUVERCLE</p> <p>WARNING – DO NOT OPEN WHEN AN EXPLOSIVE ATMOSPHERE MAY BE PRESENT</p> <p>AVERTISSEMENT– NE PAS OUVRIR SI UNE ATMOSPHERE EXPLOSIVE PEUT ÊTRE PRÉSENTE</p> </td> <td> <p>LUMASENSE TECHNOLOGIES EIT IR Pyrometer LumaSense Technologies GmbH 60326 Frankfurt</p> <p>QUASAR 2 Advanced M8100-EXP</p> <p>Ref. No.: ; Serial No.:</p> <p>CE 1725 Ex II 2G Ex db IIB T4 Gb</p> <p>FM18ATEX0036X ; FM18US0126X ; FM18CA0061X ; IECEX FME 18.0002X Class I, Div. 1, Groups C & D, T4 ; Class I, Div. 2, Groups A, B, C & D, T4 Ta = -40°C to 60°C IP66 TYPE 4X 24 VDC / 115 VAC / 230 VAC 5 Watts Made in Germany www.lumasenseinc.com</p> </td> <td>  </td> </tr> </table> <p>Explosion Proof, prevent flame propagation CSA/US Class I, Division 1, Groups C and D Class I, Division 2, Groups A, B, C and D</p>	<p>CAUTION: OPEN CIRCUIT BEFORE REMOVING COVER</p> <p>ATTENTION: OUVRIR LE CIRCUIT AVANT D'ENLEVER LA COUVERCLE</p> <p>WARNING – DO NOT OPEN WHEN AN EXPLOSIVE ATMOSPHERE MAY BE PRESENT</p> <p>AVERTISSEMENT– NE PAS OUVRIR SI UNE ATMOSPHERE EXPLOSIVE PEUT ÊTRE PRÉSENTE</p>	<p>LUMASENSE TECHNOLOGIES EIT IR Pyrometer LumaSense Technologies GmbH 60326 Frankfurt</p> <p>QUASAR 2 M8100-EXP</p> <p>Ref. No.: ; Serial No.:</p> <p>CE 1725 Ex II 2G Ex db IIB T4 Gb</p> <p>FM18ATEX0036X ; FM18US0126X ; FM18CA0061X ; IECEX FME 18.0002X Class I, Div. 1, Groups C & D, T4 ; Class I, Div. 2, Groups A, B, C & D, T4 Ta = -40°C to 60°C IP66 TYPE 4X 24 VDC / 115 VAC / 230 VAC 5 Watts Made in Germany www.lumasenseinc.com</p>		<p>CAUTION: OPEN CIRCUIT BEFORE REMOVING COVER</p> <p>ATTENTION: OUVRIR LE CIRCUIT AVANT D'ENLEVER LA COUVERCLE</p> <p>WARNING – DO NOT OPEN WHEN AN EXPLOSIVE ATMOSPHERE MAY BE PRESENT</p> <p>AVERTISSEMENT– NE PAS OUVRIR SI UNE ATMOSPHERE EXPLOSIVE PEUT ÊTRE PRÉSENTE</p>	<p>LUMASENSE TECHNOLOGIES EIT IR Pyrometer LumaSense Technologies GmbH 60326 Frankfurt</p> <p>QUASAR 2 Advanced M8100-EXP</p> <p>Ref. No.: ; Serial No.:</p> <p>CE 1725 Ex II 2G Ex db IIB T4 Gb</p> <p>FM18ATEX0036X ; FM18US0126X ; FM18CA0061X ; IECEX FME 18.0002X Class I, Div. 1, Groups C & D, T4 ; Class I, Div. 2, Groups A, B, C & D, T4 Ta = -40°C to 60°C IP66 TYPE 4X 24 VDC / 115 VAC / 230 VAC 5 Watts Made in Germany www.lumasenseinc.com</p>	
<p>CAUTION: OPEN CIRCUIT BEFORE REMOVING COVER</p> <p>ATTENTION: OUVRIR LE CIRCUIT AVANT D'ENLEVER LA COUVERCLE</p> <p>WARNING – DO NOT OPEN WHEN AN EXPLOSIVE ATMOSPHERE MAY BE PRESENT</p> <p>AVERTISSEMENT– NE PAS OUVRIR SI UNE ATMOSPHERE EXPLOSIVE PEUT ÊTRE PRÉSENTE</p>	<p>LUMASENSE TECHNOLOGIES EIT IR Pyrometer LumaSense Technologies GmbH 60326 Frankfurt</p> <p>QUASAR 2 M8100-EXP</p> <p>Ref. No.: ; Serial No.:</p> <p>CE 1725 Ex II 2G Ex db IIB T4 Gb</p> <p>FM18ATEX0036X ; FM18US0126X ; FM18CA0061X ; IECEX FME 18.0002X Class I, Div. 1, Groups C & D, T4 ; Class I, Div. 2, Groups A, B, C & D, T4 Ta = -40°C to 60°C IP66 TYPE 4X 24 VDC / 115 VAC / 230 VAC 5 Watts Made in Germany www.lumasenseinc.com</p>						
<p>CAUTION: OPEN CIRCUIT BEFORE REMOVING COVER</p> <p>ATTENTION: OUVRIR LE CIRCUIT AVANT D'ENLEVER LA COUVERCLE</p> <p>WARNING – DO NOT OPEN WHEN AN EXPLOSIVE ATMOSPHERE MAY BE PRESENT</p> <p>AVERTISSEMENT– NE PAS OUVRIR SI UNE ATMOSPHERE EXPLOSIVE PEUT ÊTRE PRÉSENTE</p>	<p>LUMASENSE TECHNOLOGIES EIT IR Pyrometer LumaSense Technologies GmbH 60326 Frankfurt</p> <p>QUASAR 2 Advanced M8100-EXP</p> <p>Ref. No.: ; Serial No.:</p> <p>CE 1725 Ex II 2G Ex db IIB T4 Gb</p> <p>FM18ATEX0036X ; FM18US0126X ; FM18CA0061X ; IECEX FME 18.0002X Class I, Div. 1, Groups C & D, T4 ; Class I, Div. 2, Groups A, B, C & D, T4 Ta = -40°C to 60°C IP66 TYPE 4X 24 VDC / 115 VAC / 230 VAC 5 Watts Made in Germany www.lumasenseinc.com</p>						

Hazard Classification (See Appendix B, Area Classifications / Protection Concepts.)	Temp code – T4A NEMA – 4X IP 66 CENELEC/ATEX Approved Zone 1 Type: Ex db IIB T4
Threads	Electrical Service: ¾ inch NPT conduit
Mounting	M-4 Heavy Duty 360° swivel mount
Air	View Port Purge 1.4 bar min., 28l/min
Weight/Dimensions	48 Pounds (12 Kg) / 4.7 x 12.8 x 4.7 in (120 x 325 x 120 mm)
Varying Flame Luminescence	The LumaSense QUASAR 2-EXP automatically compensates for low and varying target emissivity (luminescence) and minimizes the effects of attenuation by intervening media, such as rain, snow and fog.

9.2 Reference Numbers

3 915 010	M8100-EXP Quasar 2 Advanced 37, 5:1
3 915 020	M8100-EXP Quasar 2 Advanced 60:1
3 915 030	M8100-EXP Quasar 2 Advanced 75:1
3 915 040	M8100-EXP Quasar 2 Advanced 150:1
3 915 050	M8100-EXP Quasar 2 Advanced 300:1
3 915 110	M8100-EXP Quasar 2 Advanced, inv. out, 37, 5:1
3 915 120	M8100-EXP Quasar 2 Advanced, inv. out, 60:1
3 915 130	M8100-EXP Quasar 2 Advanced, inv. out, 75:1
3 915 140	M8100-EXP Quasar 2 Advanced, inv. out, 150:1
3 915 150	M8100-EXP Quasar 2 Advanced, inv. out, 300:1
3 915 210	M8100-EXP Quasar 2 37, 5:1
3 915 220	M8100-EXP Quasar 2 60:1
3 915 23	M8100-EXP Quasar 2 75:1
3 915 240	M8100-EXP Quasar 2 150:1
3 915 250	M8100-EXP Quasar 2 300:1
3 915 310	M8100-EXP Quasar 2, inv. out, 37, 5:1
3 915 320	M8100-EXP Quasar 2, inv. out, 60:1
3 915 330	M8100-EXP Quasar 2, inv. out, 75:1
3 915 340	M8100-EXP Quasar 2, inv. out, 150:1
3 915 350	M8100-EXP Quasar 2, inv. out, 300:1
3 915 410	M8100-EXP Quasar 2 Advanced BU 37, 5:1
3 915 420	M8100-EXP Quasar 2 Advanced BU 60:1
3 915 430	M8100-EXP Quasar 2 Advanced BU 75:1
3 915 440	M8100-EXP Quasar 2 Advanced BU 150:1

3 915 450 M8100-EXP Quasar 2 Advanced BU 300:1
3 915 510 M8100-EXP Quasar 2 Advanced BU, inv. out, 37, 5:1
3 915 520 M8100-EXP Quasar 2 Advanced BU, inv. out, 60:1
3 915 530 M8100-EXP Quasar 2 Advanced BU, inv. out, 75:1
3 915 540 M8100-EXP Quasar 2 Advanced BU, inv. out, 150:1
3 915 550 M8100-EXP Quasar 2 Advanced BU, inv. out, 300:1
3 915 610 M8100-EXP Quasar 2 BU 37, 5:1
3 915 620 M8100-EXP Quasar 2 BU 60:1
3 915 630 M8100-EXP Quasar 2 BU 75:1
3 915 640 M8100-EXP Quasar 2 BU 150:1
3 915 650 M8100-EXP Quasar 2 BU 300:1
3 915 710 M8100-EXP Quasar 2 BU, inv. out, 37, 5:1
3 915 720 M8100-EXP Quasar 2 BU, inv. out, 60:1
3 915 730 M8100-EXP Quasar 2 BU, inv. out, 75:1
3 915 740 M8100-EXP Quasar 2 BU, inv. out, 150:1
3 915 750 M8100-EXP Quasar 2 BU, inv. out, 300:1

To ensure consistent document formatting, this page was intentionally left blank.

Appendix A: Area Classification/Protection Concepts

According to IEC/EN 60079-14

Declaration of Conformity/Certificates

Page	Description
44	IECEx Certificate of Conformity
47	EU-Type Examination Certificate – ATEX
50	Certificate of Conformity per US Requirements
53	Certificate of Conformity per Canadian Requirements



IECEX Certificate of Conformity

INTERNATIONAL ELECTROTECHNICAL COMMISSION IEC Certification Scheme for Explosive Atmospheres

for rules and details of the IECEX Scheme visit www.iecex.com

Certificate No.: IECEX FME 18.0002X Issue No: 0 Certificate history:
Issue No. 0 (2018-07-20)

Status: **Current** Page 1 of 3

Date of Issue: **2018-07-20**

Applicant: **LumaSense Technologies GmbH**
Kleyerstrasse 90, Frankfurt D-60326
Germany

Equipment: **E²T Infrared Flame Monitor Quasar 2 M8100-EXP and Quasar 2 M8100-EXP Advanced**
Optional accessory:

Type of Protection: **Flameproof 'db'**

Marking: **Ex db IIB T4 Gb Ta = -40°C to +60°C IP66**

*Approved for issue on behalf of the IECEX
Certification Body:*

Nicholas Ludlam

Position:

Deputy Certification Manager

*Signature:
(for printed version)*

Date:

1. This certificate and schedule may only be reproduced in full.
2. This certificate is not transferable and remains the property of the issuing body.
3. The Status and authenticity of this certificate may be verified by visiting the [Official IECEX Website](#).

Certificate issued by:

FM Approvals Ltd
1 Windsor Dials
SL4 1RS Windsor
United Kingdom





IECEx Certificate of Conformity

Certificate No: IECEx FME 18.0002X Issue No: 0
Date of Issue: **2018-07-20** Page 2 of 3
Manufacturer: **LumaSense Technologies GmbH**
Kleyerstrasse 90, Frankfurt D-60326
Germany

Additional Manufacturing location(s):

This certificate is issued as verification that a sample(s), representative of production, was assessed and tested and found to comply with the IEC Standard list below and that the manufacturer's quality system, relating to the Ex products covered by this certificate, was assessed and found to comply with the IECEx Quality system requirements. This certificate is granted subject to the conditions as set out in IECEx Scheme Rules, IECEx 02 and Operational Documents as amended.

STANDARDS:

The apparatus and any acceptable variations to it specified in the schedule of this certificate and the identified documents, was found to comply with the following standards:

IEC 60079-0 : 2011 Explosive atmospheres - Part 0: General requirements
Edition:6.0
IEC 60079-1 : 2014-06 Explosive atmospheres - Part 1: Equipment protection by flameproof enclosures "d"
Edition:7.0

*This Certificate **does not** indicate compliance with electrical safety and performance requirements other than those expressly included in the Standards listed above.*

TEST & ASSESSMENT REPORTS:

A sample(s) of the equipment listed has successfully met the examination and test requirements as recorded in

Test Report:

[GB/FME/ExTR18.0001/00](#)

Quality Assessment Report:

[GB/FME/QAR14.0004/02](#)



IECEx Certificate of Conformity

Certificate No: IECEx FME 18.0002X Issue No: 0
Date of Issue: 2018-07-20 Page 3 of 3

Schedule

EQUIPMENT:

Equipment and systems covered by this certificate are as follows:

The LumaSense E²T Quasar 2 series are designed for detecting & monitoring of pilot flame and flared gases from flares. The assembly consist of main housing cylinder, front housing cover assembly, back housing cover assembly and the non-contact infrared electro-optical package.

It can be configured in two models; Quasar 2 M8100-EXP and Quasar 2 M8100-EXP Advanced. The advanced system includes an intensity mA output, which allows the programming of multiple Setpoints to indicate pilot flame detection and flaring status signals from the same unit.

Both models' output are able to be inverted and the output ratios are as follows: 37.5:1, 60:1, 75:1, 150:1 and 300:1.

These Quasar 2 models can be configured as 24V dc, 115V ac or 250V ac.

39150a0, E²T Quasar 2 M8100-EXP Advanced
39151a0, E²T Quasar 2 M8100-EXP Advanced (with inverted output)
39152a0, E²T Quasar 2 M8100-EXP
39153a0, E²T Quasar 2 M8100-EXP (with inverted output)
a = Output ratio (1 = 37.5:1; 2 = 60:1; 3 = 75:1; 4 = 150:1; 5 = 300:1)

SPECIFIC CONDITIONS OF USE: YES as shown below:

1. Contact manufacturer for flamepath joint design information.
2. The cable glands, cable sealing device or blanking plugs for the unused entries (as applicable) shall be suitably certified with a minimum Ex rating of Ex db IIB Ta = -40 °C to 60 °C Gb.
3. In order to maintain an IP66 rating for the equipment, the cable glands shall be suitably certified with a minimum rating of IP66.
4. To reduce the risk due to electrostatic discharge, the user shall regularly clean the enclosures with a damp cloth to limit dust layers on the enclosure sides.

1 EU-TYPE EXAMINATION CERTIFICATE



2 Equipment or Protective systems intended for use in Potentially Explosive Atmospheres - Directive 2014/34/EU

3 EU-Type Examination Certificate No: FM18ATEX0036X

4 Equipment or protective system: E²T Quasar 2 M8100-EXP
(Type Reference and Name) E²T Quasar 2 M8100-EXP Advanced

5 Name of Applicant: LumaSense Technologies GmbH

6 Address of Applicant: Kleyerstrasse 90,
D-60326 Frankfurt
Germany

7 This equipment or protective system and any acceptable variation thereto is specified in the schedule to this certificate and documents therein referred to.

8 FM Approvals Ltd, notified body number 1725 in accordance with Article 17 of Directive 2014/34/EU of 26 February 2014, certifies that this equipment has been found to comply with the Essential Health and Safety Requirements relating to the design and construction of equipment intended for use in potentially explosive atmospheres given in Annex II to the Directive.

The examination and test results are recorded in confidential report number:

3060334 dated 5th July 2018

9 Compliance with the Essential Health and Safety Requirements, with the exception of those identified in item 15 of the schedule to this certificate, has been assessed by compliance with the following documents:

EN 60079-0:2012 + A11:2013, EN 60079-1:2014 and EN 60529:1991 + A1:2000 + A2:2013

10 If the sign 'X' is placed after the certificate number, it indicates that the equipment is subject to specific conditions of use specified in the schedule to this certificate.

11 This EU-Type Examination certificate relates only to the design, examination and tests of the specified equipment or protective system in accordance to the directive 2014/34/EU. Further requirements of the Directive apply to the manufacturing process and supply of this equipment or protective system. These are not covered by this certificate.

12 The marking of the equipment or protective system shall include:



II 2 G Ex db IIB T4 Gb Ta= -40°C to +60°C IP66



Digitally signed by Nicholas Ludlam
DN: cn=Nicholas Ludlam, o=FM Approvals, ou, email=nicholas.ludlam@fmapprovals.com, c=GB
Date: 2018.07.20 13:58:12 +01'00'

Nicholas Ludlam
Deputy Certification Manager, FM Approvals Ltd.

Issue date: 20th July 2018

THIS CERTIFICATE MAY ONLY BE REPRODUCED IN ITS ENTIRETY AND WITHOUT CHANGE

FM Approvals Ltd. 1 Windsor Dials, Windsor, Berkshire, UK. SL4 1RS
T: +44 (0) 1753 750 000 F: +44 (0) 1753 868 700 E-mail: atex@fmapprovals.com www.fmapprovals.com

F ATEX 020 (Apr/16)

Page 1 of 3

SCHEDULE



to EU-Type Examination Certificate No. FM18ATEX0036X

13 Description of Equipment or Protective System:

The LumaSense E²T Quasar 2 series are designed for detecting & monitoring of pilot flame and flared gases from flares. The assembly consist of main housing cylinder, front housing cover assembly, back housing cover assembly and the non-contact infrared electro-optical package.

It can be configured in two models; Quasar 2 M8100-EXP and Quasar 2 M8100-EXP Advanced. The advanced system includes an intensity mA output, which allows the programming of multiple Setpoints to indicate pilot flame detection and flaring status signals from the same unit. Both models' output are able to be inverted and the output ratios are as follows: 37.5:1, 60:1, 75:1, 150:1 and 300:1.

Operation Temperature Ranges: The ambient operating temperature range is -40°C to 60°C.

Electrical data: The voltage ratings are 24V dc, 115V ac or 250V ac.

39150a0, E²T Quasar 2 M8100-EXP Advanced

39151a0, E²T Quasar 2 M8100-EXP Advanced (with inverted output)

39152a0, E²T Quasar 2 M8100-EXP

39153a0, E²T Quasar 2 M8100-EXP (with inverted output)

a = Output ratio (1 = 37.5:1; 2 = 60:1; 3 = 75:1; 4 = 150:1; 5 = 300:1)

14 Specific Conditions of Use:

1. Contact manufacturer for flamepath joint design information.
2. The cable glands, cable sealing device or blanking plugs for the unused entries (as applicable) shall be suitably certified with a minimum Ex gas rating of Ex db IIB Ta = -40°C to 60°C Gb.
3. In order to maintain an IP66 rating for the equipment, the cable glands shall be suitably certified with a minimum rating of IP66.
4. To reduce the risk due to electrostatic discharge, the user shall regularly clean the enclosures with a damp cloth to limit dust layers on the enclosure sides.

15 Essential Health and Safety Requirements:

The relevant EHSRs that have not been addressed by the standards listed in this certificate have been identified and assessed in the confidential report identified in item 8.

16 Test and Assessment Procedure and Conditions:

This EU-Type Examination Certificate is the result of testing of a sample of the product submitted, in accordance with the provisions of the relevant specific standard(s), and assessment of supporting documentation. It does not imply an assessment of the whole production.

Whilst this certificate may be used in support of a manufacturer's claim for CE Marking, FM Approvals Ltd accepts no responsibility for the compliance of the equipment against all applicable Directives in all applications.

This Certificate has been issued in accordance with FM Approvals Ltd's ATEX Certification Scheme.

17 Schedule Drawings

A list of the significant parts of the technical documentation is annexed to this certificate and a copy has been kept by the Notified Body.

THIS CERTIFICATE MAY ONLY BE REPRODUCED IN ITS ENTIRETY AND WITHOUT CHANGE

FM Approvals Ltd, 1 Windsor Dials, Windsor, Berkshire, UK, SL4 1RS
T: +44 (0) 1753 750 000 F: +44 (0) 1753 868 700 E-mail: atex@fmapprovals.com www.fmapprovals.com

F.ATEX 020 (Apr/16)

Page 2 of 3

SCHEDULE



to EU-Type Examination Certificate No. FM18ATEX0036X

18 Certificate History

Details of the supplements to this certificate are described below:

Date	Description
20 th July 2018	Original Issue.



THIS CERTIFICATE MAY ONLY BE REPRODUCED IN ITS ENTIRETY AND WITHOUT CHANGE

FM Approvals Ltd. 1 Windsor Dials, Windsor, Berkshire, UK. SL4 1RS
T: +44 (0) 1753 750 000 F: +44 (0) 1753 868 700 E-mail: atex@fmapprovals.com www.fmapprovals.com

F.ATEX 020 (Apr/16)

Page 3 of 3

CERTIFICATE OF CONFORMITY



1. **HAZARDOUS (CLASSIFIED) LOCATION ELECTRICAL EQUIPMENT PER US REQUIREMENTS**
2. **Certificate No:** FM18US0126X
3. **Equipment:** E²T Quasar 2 M8100-EXP
(Type Reference and Name) E²T Quasar 2 M8100-EXP Advanced
4. **Name of Listing Company:** LumaSense Technologies GmbH
5. **Address of Listing Company:** Kleyerstrasse 90,
D-60326 Frankfurt
Germany
6. The examination and test results are recorded in confidential report number:

3061334 dated 5th July 2018
7. FM Approvals LLC, certifies that the equipment described has been found to comply with the following Approval standards and other documents:

FM Class 3600:2018, FM Class 3611:2016, FM Class 3615:2018, FM Class 3810:2018
ANSI/NEMA 250:2008, ANSI/IEC 60529:R2011
8. If the sign 'X' is placed after the certificate number, it indicates that the equipment is subject to specific conditions of use specified in the schedule to this certificate.
9. This certificate relates to the design, examination and testing of the products specified herein. The FM Approvals surveillance audit program has further determined that the manufacturing processes and quality control procedures in place are satisfactory to manufacture the product as examined, tested and Approved.
10. **Equipment Ratings:**

Explosionproof for Class I, Division 1, Groups C, and D; and Non-Incendive for use in Class I, Division 2, Groups A, B, C and D hazardous (classified) locations.
The Temperature Code is T4 for ambient temperature range Ta = -40°C to 60°C with indoors and outdoors rating Type 4X and ingress protection IP66.

Certificate issued by:

J.E. Marquedant

J.E. Marquedant
VP, Manager, Electrical Systems

5 July 2018

Date

To verify the availability of the Approved product, please refer to www.approvalguide.com

THIS CERTIFICATE MAY ONLY BE REPRODUCED IN ITS ENTIRETY AND WITHOUT CHANGE

FM Approvals LLC, 1151 Boston-Providence Turnpike, Norwood, MA 02062 USA
T: +1 (1) 781 762 4300 F: +1 (1) 781 762 9375 E-mail: information@fmapprovals.com www.fmapprovals.com

F 347 (Mar 16)

Page 1 of 3

SCHEDULE



US Certificate Of Conformity No: FM18US0126X

11. The marking of the equipment shall include:

Class I Division 1, Groups C and D; T4
Class I Division 2, Groups A, B, C and D; T4
Ta = -40°C to +60°C; Type 4X, IP66

12. **Description of Equipment:**

The LumaSense E²T Quasar 2 series are designed for detecting & monitoring of pilot flame and flared gases from flares. The assembly consist of main housing cylinder, front housing cover assembly, back housing cover assembly and the non-contact infrared electro-optical package.
It can be configured in two models; Quasar 2 M8100-EXP and Quasar 2 M8100-EXP Advanced. The advanced system includes an intensity mA output, which allows the programming of multiple Setpoints to indicate pilot flame detection and flaring status signals from the same unit. Both models' output are able to be inverted and the output ratios are as follows: 37.5:1, 60:1, 75:1, 150:1 and 300:1.

Operation Temperature Ranges: The ambient operating temperature range is -40°C to 60°C.

Electrical data: The voltage ratings are 24V dc, 115V ac or 250V ac.

The model structure of the E²T Quasar 2 series is shown below.

39150a0, E²T Quasar 2 M8100-EXP Advanced
39151a0, E²T Quasar 2 M8100-EXP Advanced (with inverted output)
39152a0, E²T Quasar 2 M8100-EXP
39153a0, E²T Quasar 2 M8100-EXP (with inverted output)
a = Output ratio (1 = 37.5:1; 2 = 60:1; 3 = 75:1; 4 = 150:1; 5 = 300:1)

13. **Specific Conditions of Use:**

1. Contact manufacturer for flamepath joint design information.
2. The cable glands, cable sealing device or blanking plugs for the unused entries (as applicable) shall be suitably certified with a minimum rating of Class I, Division 1, Groups C & D for Division 1 wiring & Class I, Division 2, Groups A, B, C & D for Division 2 wiring.
3. To reduce the risk due to electrostatic discharge, the user shall regularly clean the enclosures with a damp cloth to limit dust layers on the enclosure sides.

14. **Test and Assessment Procedure and Conditions:**

This Certificate has been issued in accordance with FM Approvals US Certification Requirements.

15. **Schedule Drawings**

A copy of the technical documentation has been kept by FM Approvals.

THIS CERTIFICATE MAY ONLY BE REPRODUCED IN ITS ENTIRETY AND WITHOUT CHANGE

FM Approvals LLC, 1151 Boston-Providence Turnpike, Norwood, MA 02062 USA
T: +1 (1) 781 762 4300 F: +1 (1) 781 762 9375 E-mail: information@fmaprovals.com www.fmaprovals.com

F 347 (Mar 16)

Page 2 of 3

SCHEDULE

US Certificate Of Conformity No: FM18US0126X



16. Certificate History

Details of the supplements to this certificate are described below:

Date	Description
5 th July 2018	Original Issue.

THIS CERTIFICATE MAY ONLY BE REPRODUCED IN ITS ENTIRETY AND WITHOUT CHANGE

FM Approvals LLC, 1151 Boston-Providence Turnpike, Norwood, MA 02062 USA
T: +1 (1) 781 762 4300 F: +1 (1) 781 762 9375 E-mail: information@fmaprovals.com www.fmaprovals.com

F 347 (Mar 16)

Page 3 of 3

CERTIFICATE OF CONFORMITY



1. **HAZARDOUS LOCATION ELECTRICAL EQUIPMENT PER CANADIAN REQUIREMENTS**
2. **Certificate No:** FM18CA0061X
3. **Equipment:** E²T Quasar 2 M8100-EXP
(Type Reference and Name) E²T Quasar 2 M8100-EXP Advanced
4. **Name of Listing Company:** LumaSense Technologies GmbH
5. **Address of Listing Company:** Kleyerstrasse 90,
D-60326 Frankfurt
Germany
6. The examination and test results are recorded in confidential report number:

3061334 dated 5th July 2018
7. FM Approvals LLC, certifies that the equipment described has been found to comply with the following Approval standards and other documents:

CSA-C22.2 No. 0.4:2017, CSA-C22.2 No. 0.5:2016, CSA-C22.2 No. 30:R2016, CSA-C22.2 No. 94:R2011, CSA-C22.2 No. 213:2016, CAN/CSA-C22.2 No. 61010-1:2012, CSA-C22.2 No. 60529:R2010
8. If the sign 'X' is placed after the certificate number, it indicates that the equipment is subject to specific conditions of use specified in the schedule to this certificate.
9. This certificate relates to the design, examination and testing of the products specified herein. The FM Approvals surveillance audit program has further determined that the manufacturing processes and quality control procedures in place are satisfactory to manufacture the product as examined, tested and Approved.
10. **Equipment Ratings:**

Explosionproof for Class I, Division 1, Groups C, and D; and Non-incendive for use in Class I, Division 2, Groups A, B, C and D hazardous locations.
The Temperature Code is T4 for ambient temperature range Ta = -40°C to 60°C with indoors and outdoors rating Type 4X and ingress protection IP66.

Certificate issued by:

J.E. Marquedant
VP, Manager, Electrical Systems

5 July 2018
Date

To verify the availability of the Approved product, please refer to www.approvalguide.com

THIS CERTIFICATE MAY ONLY BE REPRODUCED IN ITS ENTIRETY AND WITHOUT CHANGE

FM Approvals LLC, 1151 Boston-Providence Turnpike, Norwood, MA 02062 USA
T: +1 (1) 781 762 4300 F: +1 (1) 781 762 9375 E-mail: information@fmapprovals.com www.fmapprovals.com

F 348 (Mar 16)

Page 1 of 3

SCHEDULE



Canadian Certificate Of Conformity No: FM18CA0061X

11. The marking of the equipment shall include:

Class I Division 1, Groups C and D; T4
Class I Division 2, Groups A, B, C and D; T4
Ta = -40°C to +60°C; Type 4X, IP66

12. **Description of Equipment:**

The LumaSense E²T Quasar 2 series are designed for detecting & monitoring of pilot flame and flared gases from flares. The assembly consist of main housing cylinder, front housing cover assembly, back housing cover assembly and the non-contact infrared electro-optical package.
It can be configured in two models; Quasar 2 M8100-EXP and Quasar 2 M8100-EXP Advanced. The advanced system includes an intensity mA output, which allows the programming of multiple Setpoints to indicate pilot flame detection and flaring status signals from the same unit. Both models' output are able to be inverted and the output ratios are as follows: 37.5:1, 60:1, 75:1, 150:1 and 300:1.

Operation Temperature Ranges: The ambient operating temperature range is -40°C to 60°C.

Electrical data: The voltage ratings are 24V dc, 115V ac or 250V ac.

The model structure of the E²T Quasar 2 series is shown below.

39150a0, E²T Quasar 2 M8100-EXP Advanced
39151a0, E²T Quasar 2 M8100-EXP Advanced (with inverted output)
39152a0, E²T Quasar 2 M8100-EXP
39153a0, E²T Quasar 2 M8100-EXP (with inverted output)
a = Output ratio (1 = 37.5:1; 2 = 60:1; 3 = 75:1; 4 = 150:1; 5 = 300:1)

13. **Specific Conditions of Use:**

1. Contact manufacturer for flamepath joint design information.
2. The cable glands, cable sealing device or blanking plugs for the unused entries (as applicable) shall be suitably certified with a minimum rating of Class I, Division 1, Groups C & D for Division 1 wiring & Class I, Division 2, Groups A, B, C & D for Division 2 wiring.
3. To reduce the risk due to electrostatic discharge, the user shall regularly clean the enclosures with a damp cloth to limit dust layers on the enclosure sides.

14. **Test and Assessment Procedure and Conditions:**

This Certificate has been issued in accordance with FM Approvals Canadian Certification Scheme.

15. **Schedule Drawings**

A copy of the technical documentation has been kept by FM Approvals.

THIS CERTIFICATE MAY ONLY BE REPRODUCED IN ITS ENTIRETY AND WITHOUT CHANGE

FM Approvals LLC, 1151 Boston-Providence Turnpike, Norwood, MA 02062 USA
T: +1 (1) 781 762 4300 F: +1 (1) 781 762 9375 E-mail: information@fmaprovals.com www.fmaprovals.com

F 348 (Mar 16)

Page 2 of 3

SCHEDULE



Canadian Certificate Of Conformity No: FM18CA0061X

16. Certificate History

Details of the supplements to this certificate are described below:

Date	Description
5 th July 2018	Original Issue.

THIS CERTIFICATE MAY ONLY BE REPRODUCED IN ITS ENTIRETY AND WITHOUT CHANGE

FM Approvals LLC, 1151 Boston-Providence Turnpike, Norwood, MA 02062 USA
T: +1 (1) 781 762 4300 F: +1 (1) 781 762 9375 E-mail: information@fmaprovals.com www.fmaprovals.com

F 348 (Mar 16)

Page 3 of 3

To ensure consistent document formatting, this page was intentionally left blank.

Appendix B: Engineering Drawings

Page	Dwg.#	Description
58	3 915 112	Isometric Assembly, M8100PM-EXP Mechanical Installation
59	68841840	Dimensioning drawing on M-4 swivel mount
60	App1	Service Connections, left side view, M8100-EXP
61	App2	Service Connections, right side view, M8100-EXP

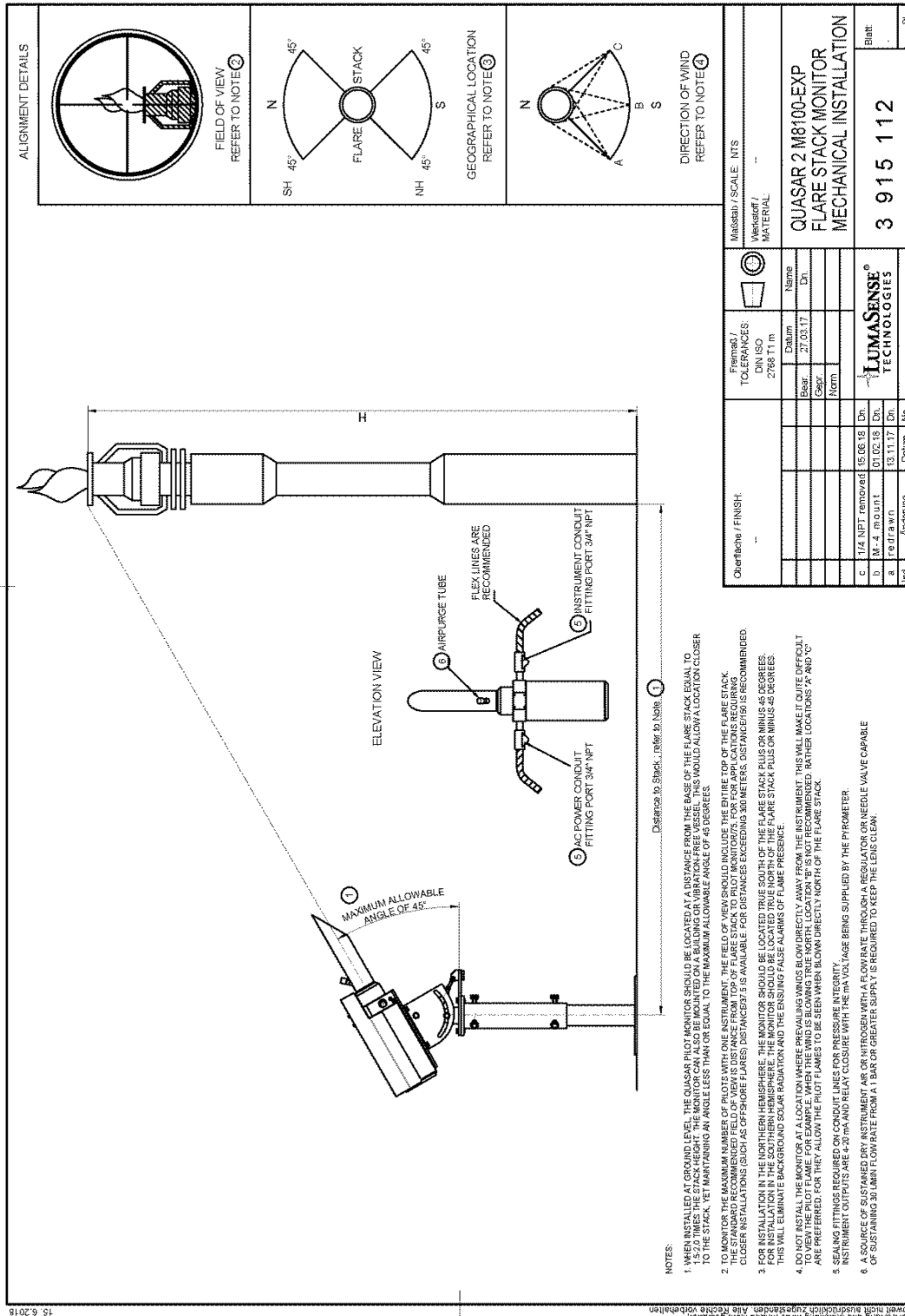

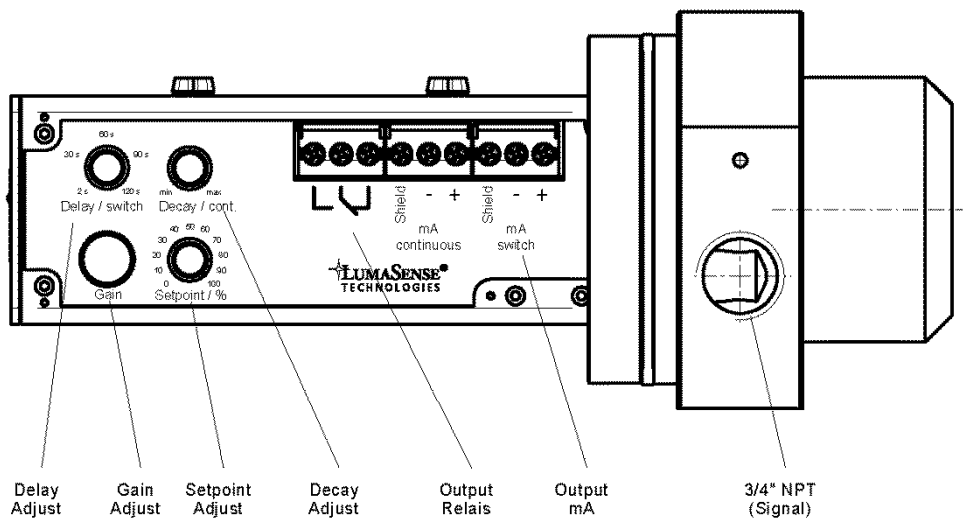
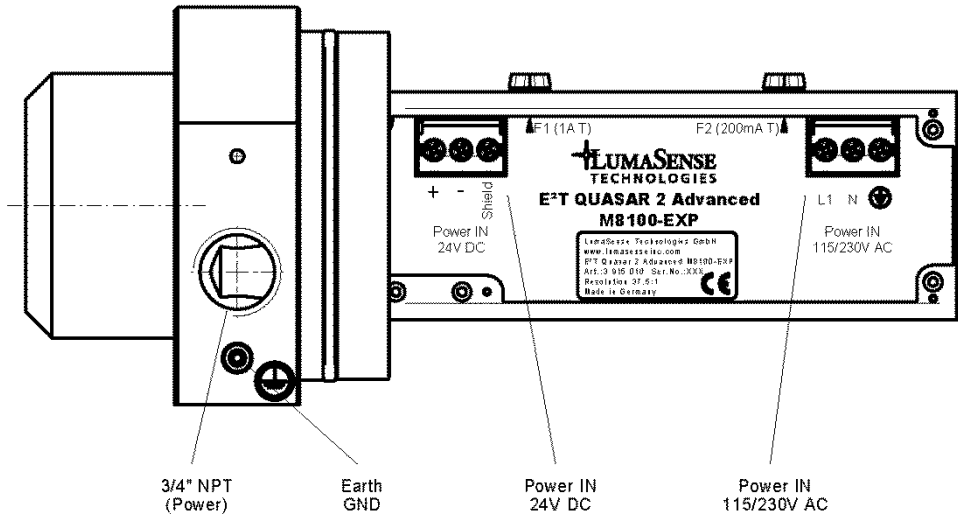

Quasar 2 Advanced

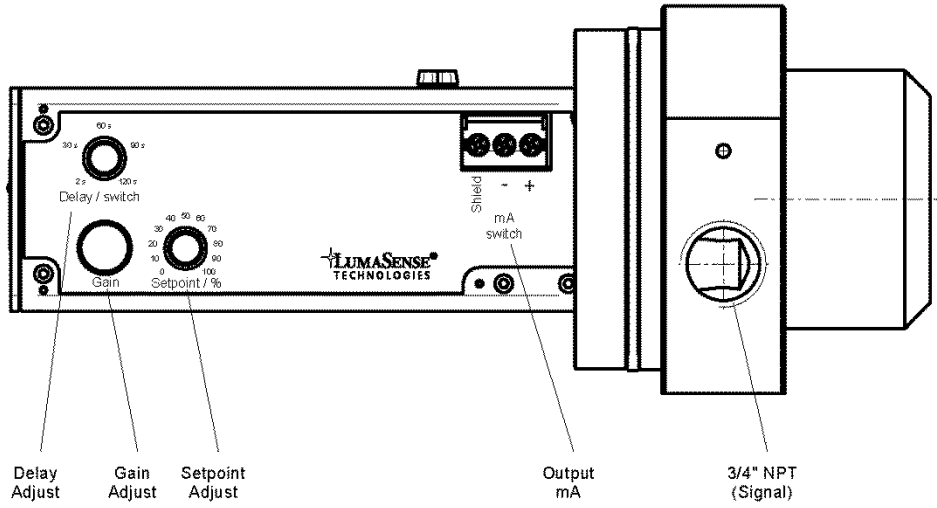

Quasar 2

To ensure consistent document formatting, this page was intentionally left blank.

Index

A

Alarm Setpoint 17
Ambient Temperature 22
Area Classification/Protection Concepts 43

C

Certificates 43
Cleaning the Optics 35
Conditions of Use 25, 37
Conduit/Connections 25

D

Delay and Decay Setting 31
Disposal / Decommissioning 14

E

Electrical Installation 25
Electrical Service Protection 38
Engineering Drawings 57
Explosion Proof Housing 12

F

Focusing Range 23
Fusing 28

H

Hazardous Environment Safety 37

I

Installation / Start-up 18

L

LED Indicators 32
Legend 11

M

mA Output 28
Maintenance 35
Mechanical Installation 21

Milliamp Output 32
Mounting 22

O

Operating the QUASAR 2 M8100-EXP 29
Optical Alignment 33

P

Power Connections 26
Power Fuse 33
Power Input 33
Powering with 115 Volts 27
Powering with 24 Volts 27

Q

Quick Installation 17

R

Reference Numbers 40
Relay Contacts 17, 32

S

Safety Assurances and Precautions 37
Sight Assessment 21
Sight Path 33
Signal Path 17
Specifications 39
Start-Up Operation 31
System Features 16
System Overview 15

T

Target Size 23
Troubleshooting 33

U

Unpacking and Inspection 13