

AIRTECH[®]

THE LONG

Clean Air Innovation

THE LONG AIRTECH JOINT STOCK COMPANY

Head Office

No 144 Viet Hung Str., Long Bien Dist., Ha Noi City., Viet Nam

Factory

IN9.4, No 1 Str., VSIP Industrial Park, Luong Dien Comm.,
Cam Giang Dist., Hai Duong Prov., Viet Nam

Representative Office

E5/34A, Lien Ap 5-6, Vinh Loc A Comm.,
Binh Chanh Dist., Ho Chi Minh City, Viet Nam

Tel: 024.38737717 - Fax: 024.38726894

Email: info@thelong.com.vn - Website: www.airtechthelong.com.vn



AIRTECH[®]

THE LONG

Clean Air Innovation



CATALOGUE
**BIOLOGICAL
CABINET**

COMPANY PROFILE

The Long Airtech Joint Stock Company (ATV) was established under the first name "The Long Commercial Technology Company Limited" in March 2007. On the early start-up time, The Long Company did commercial business with products which served corporations from industrial zones. Specially, 2016 marked the new development of The Long Company when The Long signed associated technology cooperation and joint venture production with Airtech Japan Company (ATJ) then change its name to "The Long Airtech Joint Stock Company" in March 2017. Up to now, The Long Airtech Joint Stock Company has affirmed its position in Vietnam market and been proud of leading the way in producing for clean room models, medical equipment, laboratory equipment and high-tech air filtration systems.



Through 10 years of development, we are proud of creating a prestigious brand and reputation in Vietnam market, specially, for foreign joint venture partners as well as electromagnetic, medical and foods companies. We concentrate on the development of items relating to auxiliary industries, industrial zones, electromagnetic companies and pharmaceutical manufacturers. Moreover, we supply high technology products to other fields like operating rooms, hospitals. Its primary business focuses lies in the clean air equipment and clean room construction industry. Our services such as consulting, designing, installation of clean room, air filtration system, clean room materials, antistatic materials, raised floor and components... for pharmacy, electronics, medicine, food and beverage, semiconductors are highly appreciated by both domestic and oversea customers. These mainstream products which are Air Showers (AS), Pass Boxes (PB), Fan Filter Unit (FFU), Bio-Safety Cabinet (BSC), Fume Hood (FH), Clean Bench (CB)... are incessantly improved.



Air Shower



Blower Filter Unit



Bio-safety cabinet



Fan Filter Unit



Fume hood



HEPA Filter Unit



Clean bench



Passbox



Chemical storage cabinet

Our employees are who directly bring the success for the company thanks to skillfull hands, smart brain, high responsibility and good majority. As a result, high technology products of ATV step by step show off their position in the Vietnam market and become one of the best technology products in this country. Being located in Tan Quang Industrial zone, Van Lam district, Hung Yen province, the factory has gotten innovated equipment, high technology progress, hence, provides the best necessary production, researches and improved products meeting the needs of checking sample and satisfies the most fastidious customers. In here, specialized model in steps production is applied in order to control the minimum of risk. Each detail of machine, each product is always checked carefully so as to be suitable for property, purpose of use, safety, friendliness and lead to the future. The production of ATV always put quality requirements on top. Therefore, from the very beginning, we have applied the quality management system ISO 9001-2015, aiming to meticulous products, detail of materials as well as safe and environmentally friendly production line. Each product of ATV obtains our wishing, new technology and trailblazing ideas of cleanroom production.



ATV is developing some main groups of customers. Hospital and medical examination center, electronic factory, pharmaceutical factory, beverage and foods factory, industrial factory. Catching opportunities to reach out to the world and prove itself, ATV pioneerly cooperates with foreign partner, increases relations, extensively integrate and endurable sticking not only domestics but also foreign countries which lead to reaching advanced technology science, developing our products and expanding market to the world. Inside, cooperating with Airtech Japan Group is a right step of our choice, because Japan is the country of Technology with many products that are people-oriented, delicately designed, modern, qualified and durable.



Under the leadership of an experienced management team and enthusiastic staff working in accordance to ISO 9001:2015, ATV aims to improve the quality of products, services and trust of customers. We are thankful to the partners, colleagues who have always trusted the company and hope to have a good relationship, grow and prosper together.

WORLDWIDE LOCATION

STT	ABB	COMPANY NAME	NATION
01	ATJ	Airtech Japan Co., Ltd.	Japan
02	SAT	Suzhou Antal Airtech Co., Ltd.	China
03	ATE	Airtech Equipment PTE Co., Ltd.	Singapore
04	ATS	Airtech System Co., Ltd.	Taiwan
05	WAT	Woolee Airtech Korea Co., Ltd.	Korea
06	PAT	Pyramid Airtech PVT Co., Ltd.	India
07	PEA	Pharma- und Elektrotechnik- Anlagenbau GMBH Co.,Ltd.	Germany
08	ATV	The Long Airtech, Jsc.	Vietnam

COMPANY ACHIEVEMENT



Quality Control based on ISO 9001:2015



Calibration Certificate for Air Shower



Calibration Certificate for Sound Level Meter



Calibration Certificate for Air Speed Meter



Calibration Certificate for Particle Counter



Calibration Certificate for Falling Meter



Certificate of Testing Bio-Safety Cabinet

BIOLOGICAL SAFETY CABINET INTRODUCTION

BIOLOGICAL SAFETY CABINET (BSC) is a personnel safety and protection facilities that shall control the polluted aerosol emission as the first barrier to keep the operator or environment away from its hazards. Bio-safety Cabinet can be divided into 3 kinds: Class I, Class II, Class III. The most widely used is Class II A2 type: 30% exhaust, 70% circulate.

MODEL CLASSIFICATION

ATV-BSC-1000

ATV-BSC-1300

ATV-BSC-1600



MODEL DESCRIPTION

ATV - BSC - 1600

Base on outside width
1000: 1000mm
1300: 1300mm
1600: 1600mm

Biological Safety Cabinet

AIRTECH THE LONG

OPERATING PRINCIPLE

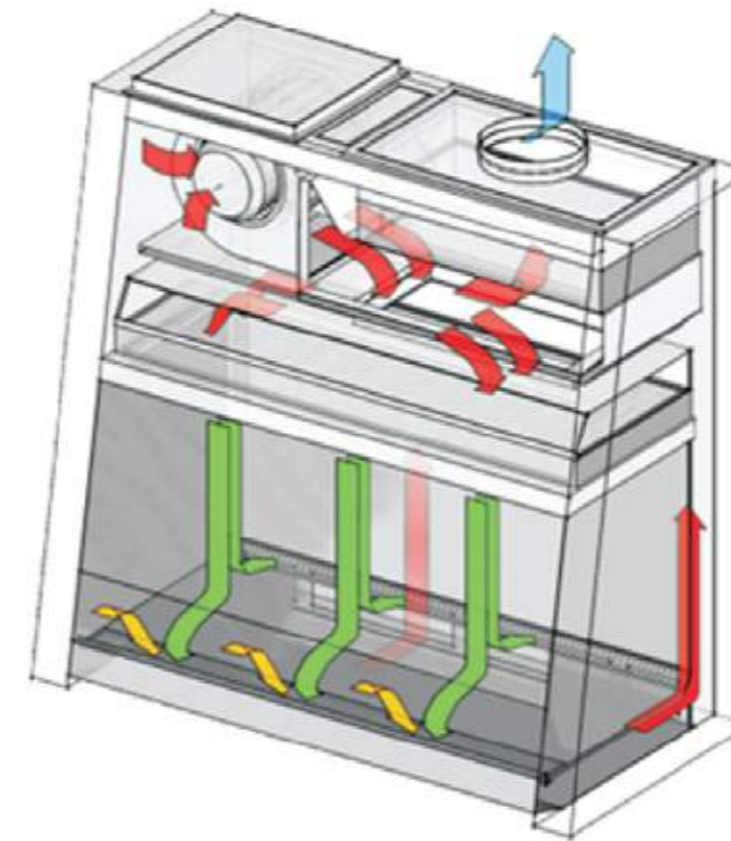

- CIRCULATION AIR
- INFLOW AIR
- DOWNFLOW AIR
- EXHAUST AIR

Ambient air is pulled through front grille to create inflow, without going into the work surface. Inflow is joined by half of the downflow, to create front air curtain that is ne-tuned to create a large performance envelope. The combined air stream travels through the back air column towards the blower.

Approximately 1/3 of the air in the common plenum is exhausted through the HEPA filter to the room. The remaining 2/3 of the air is passed through the downflow HEPA filter and into the work area as a vertical laminar flow air to create ISO Class 3 work surface and prevents cross contamination.

Near the work surface, the downflow splits. About half goes to the front grille, and half goes to the rear grille. A small portion enters the side capture zones to prevent dead air corners (small blue arrows).

The design was optimized to give large performance envelope that provides operator and product protection at wide Inflow and downflow variation from the Nominal point.

COMPONENT



FAN: Bio safety fan are long-life products which resistant to impacts of the environment. Fans are with beautiful design, energy saving and significant noise reduction.

FRAME MATERIAL is made of high quality electrostatic powder coated steel or SUS304, creating an anticorrosive, durable, sharp and aesthetical design.



CASTER Lockable square sole rubber casters are suitable for cabinets with smooth operation and high durability.



CONTROL PANEL: is delicately designed, showing the full control function that air shower can perform. Soft button makes operation accurate and convenient for the user. Time is displayed by stable 7 bars LEDs.

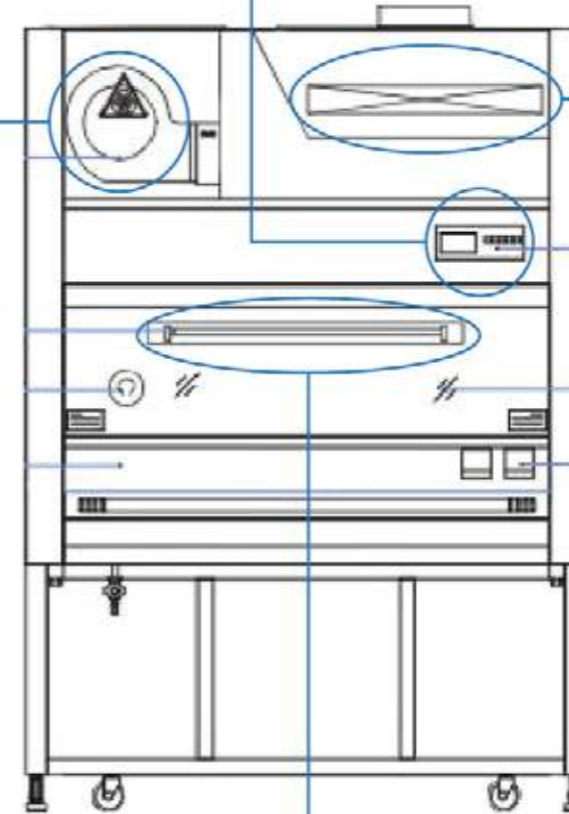

AIR FILTER: The pre-filter removes large particles to protect and extend the life of the HEPA filter. The HEPA filter effectively removes 99.999% of airborne particles 0.3 microns (μm) of diameter, creating a clean and safe environment.

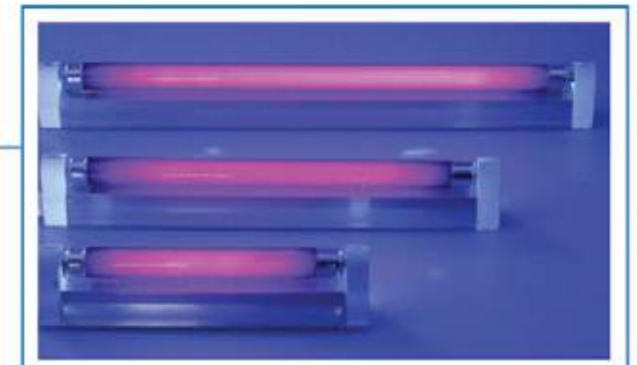

UV LAMP: Provides line of defense against spreading airborne bacteria, kills airborne bacteria, exclusive safety features, simple installation, exclusive safety.

TEMPERED GLASS is a safety glass which increases the surface tension, increase the bearing capacity, impact resistance, high load and crack resistance.

MODULE FORM AND SPECIFICATION

ATV-BSC-1000/1300/1600A2 BIOSAFETY CABINET

MODEL AND ITEM	ATV - BSC - 1000IIA2	ATV - BSC - 1300IIA2	ATV - BSC - 1600IIA2
Cleanliness	HEPA: ISO5 (Class 100) / ULPA: ISO4 (Class 10)		
Filtration Efficiency	HEPA: ≥ 99.995%,@0.3 μm / ULPA: ≥ 99.999%,@0.12 μm		
Downflow Velocity	0.35 (m/s)		
Inflow Velocity	0.55 (m/s)		
Noise	≤63 dB(A)		
Power Supply	~220V, 50Hz		
Operator Protection	Total colony in impaction sampler ≤10CFU/time		
	Total colony in slot sampler ≤ 5CFU./time		
Product Protection	Total colony in slot sampler ≤ 5CFU./time		
Cross Contamination	Total colony in slot sampler ≤ 2CFU./time		
Power(with spare socket)	2.0 (kVA)	2.1 (kVA)	2.2 (kVA)
Weight	260 (kg)	300 (kg)	350 (kg)
Work Dimension	970 x 600 x 620 (mm)	1270 x 600 x 620 (mm)	1570 x 600 x 620 (mm)
Overall Dimension	1200 x 790 x 2050 (mm)	1500 x 790 x 2050 (mm)	1800 x 790 x 2050 (mm)
Size and Qty. of Light	36W x 2 (unit)		
Size and Qty. of UV Light	20W x 1 (unit)	30W x 1 (unit)	40W x 1 (unit)
Lumin	≥800Lx		
Air Direction	Top out		

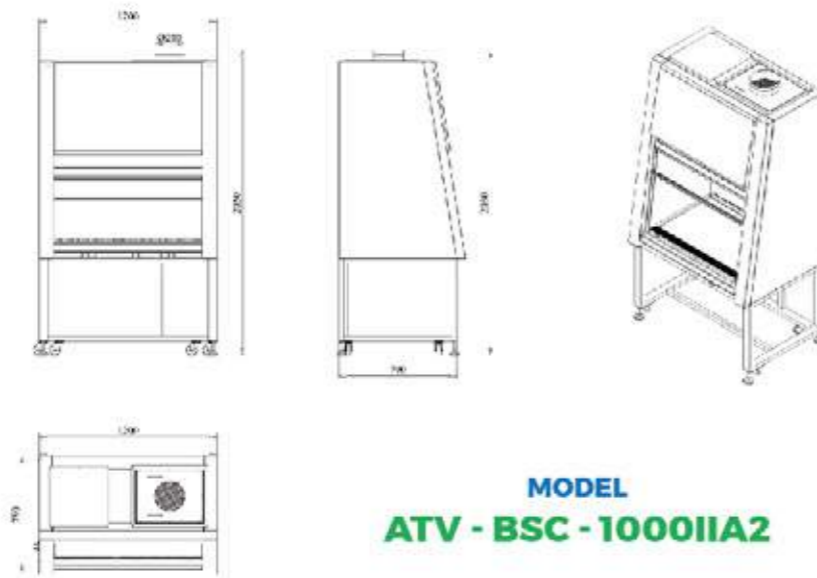

MODEL
ATV - BSC - 1000IIA2

MODULE FORM AND SPECIFICATION

ATV-BSC-1000/1300/1600IIB2 BIOSAFETY CABINET

MODEL AND ITEM	ATV - BSC - 1000IIB2	ATV - BSC - 1300IIB2	ATV - BSC - 1600IIB2
Cleanliness	HEPA: ISO5 (Class 100) / ULPA: ISO4 (Class 10)		
Filtration Efficiency	HEPA: ≥ 99.995%,@0.3 μm / ULPA: ≥ 99.999%,@0.12 μm		
Downflow Velocity	0.35 (m/s)		
Inflow Velocity	0.55 (m/s)		
Noise	≤56 dB(A)	≤58 dB(A)	≤60 dB(A)
Power Supply	~220V, 50Hz		
Operator Protection	Total colony in impaction sampler ≤10CFU/time		
	Total colony in slot sampler ≤ 5CFU./time		
Product Protection	Total colony in slot sampler ≤ 5CFU./time		
Cross Contamination	Total colony in slot sampler ≤ 2CFU./time		
Power(with spare socket)	2.0 (kVA)	2.1 (kVA)	2.2 (kVA)
Weight	260 (kg)	340 (kg)	380 (kg)
Work Dimension	970 x 600 x 620 (mm)	1270 x 600 x 620 (mm)	1570 x 600 x 620 (mm)
Overall Dimension	1200 x 790 x 2050 (mm)	1500 x 790 x 2050 (mm)	1800 x 790 x 2050 (mm)
Size and Qty. of Light	36W x 2 (unit)		
Size and Qty. of UV Light	20W x 1 (unit)	30W x 1 (unit)	40W x 1 (unit)
Lumin	≥800Lx		
Air Direction	Top out		



MODEL
ATV - BSC - 1000IIB2



CLEAN BENCH INTRODUCTION

CLEAN BENCH (CB) is a kind of general-purpose air purifying equipment that provides local high cleanliness work environment. It is mainly used in medical institutions, and also industries and scientific laboratories such as electron, national defense, precision instrument and meter, pharmacy, chemical industry, agriculture and biology etc. It may help on improving process environment, product quality and product yield. According to the direction of air flow, clean benches can be divided into Horizontal Flow and Vertical Flow types.



VERTICAL LAMINAR MODEL

HORIZONTAL LAMINAR MODEL

ATV-VCB1000

ATV-HCB1000

ATV-VCB1300

ATV-HCB1400

ATV-VCB1600

ATV-HCB1600

MODEL DESCRIPTION

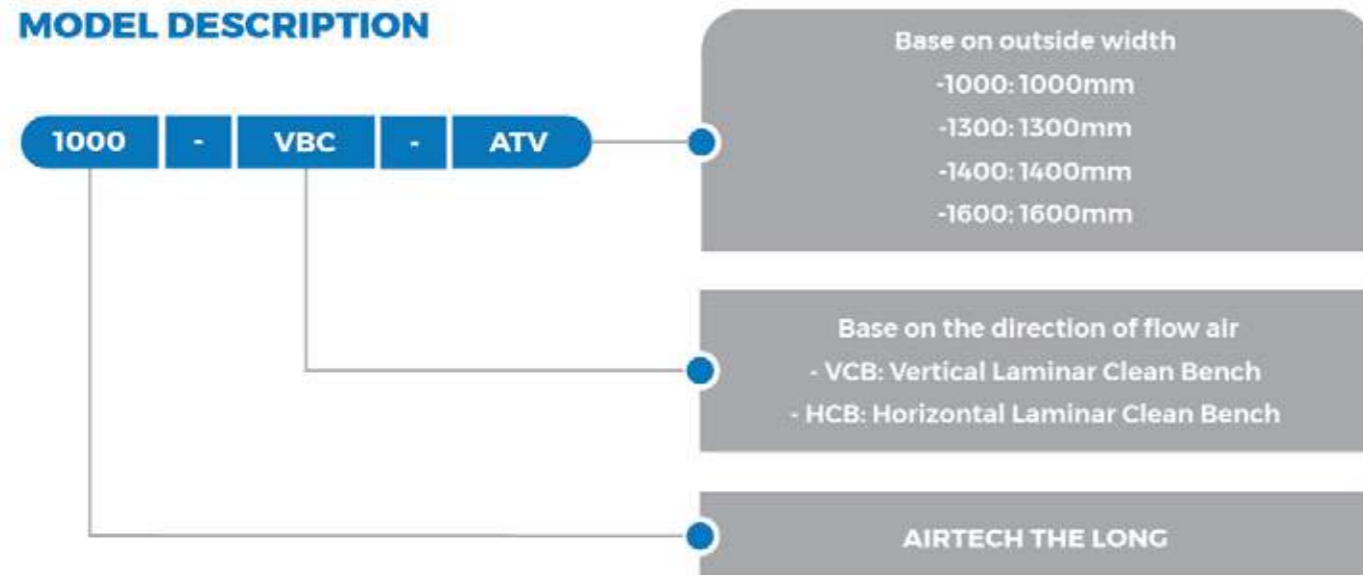

COMPONENT



FRAME MATERIAL: is made of high quality electrostatic powder coated steel or INOX SUS304, creating an anticorrosive, durable, sharp and aesthetical design.



AIR FILTER: The pre-filter removes large particles to protect and extend the life of the HEPA filter. The HEPA filter effectively removes 99.999% of airborne particles 0.3 microns (μm) of diameter, creating a clean and safe environment.



FAN: Air shower fans are long-life products which resistant to impacts of the environment. Fans are imported from China with beautiful design, energy saving and significant noise reduction.



CONTROL PANEL: is delicately designed, showing the full control function that CLEAN BENCH can perform. Soft button makes operation accurate and convenient for the user. Time is displayed by stable 7 bars LEDs.



TEMPERED GLASS: is a safety glass which increases the surface tension, increase the bearing capacity, impact resistance, high load and crack resistance.



CASTER: Lockable square sole rubber casters are suitable for cabinets with smooth operation and high durability.

MODULE FORM AND SPECIFICATION

VERTICAL LAMINAR CLEAN BENCH

MODEL	ATV-VCB1000	ATV-VCB1300	ATV-VCB1600
Type	Single		Double
Overall dimensions (W x D x H)	1000 x 810 x 1735 (mm)	1350 x 810 x 1735 (mm)	1600 x 760 x 1735 (mm)
Working dimensions (W x D x H)	800 x 700 x 650 (mm)	1200 x 700 x 650 (mm)	1400 x 700 x 650 (mm)
Airflow rate	0.3 - 0.5 (m/s)		
Materials	Frame: Electrostatic powder coated steel, bright grey color		
	Working table: SUS 304		
	Window: Toughened glass, T = 5 mm		
Coarse filter	Polyester, washable		
HEPA filter	Efficiency: 99.99% (@≥ 0.3 micron)		
Noise level	<60 dB		
Florescent lamp	18W x 1	28W x 1	36W x 1
UV lamp	14W x 1	20W x 1	30W x 1
Castor	Universal		
Power supply	220V/50Hz		
Auxiliary parts	Florescent lamp, UV lamp, stands, 2 sockets		

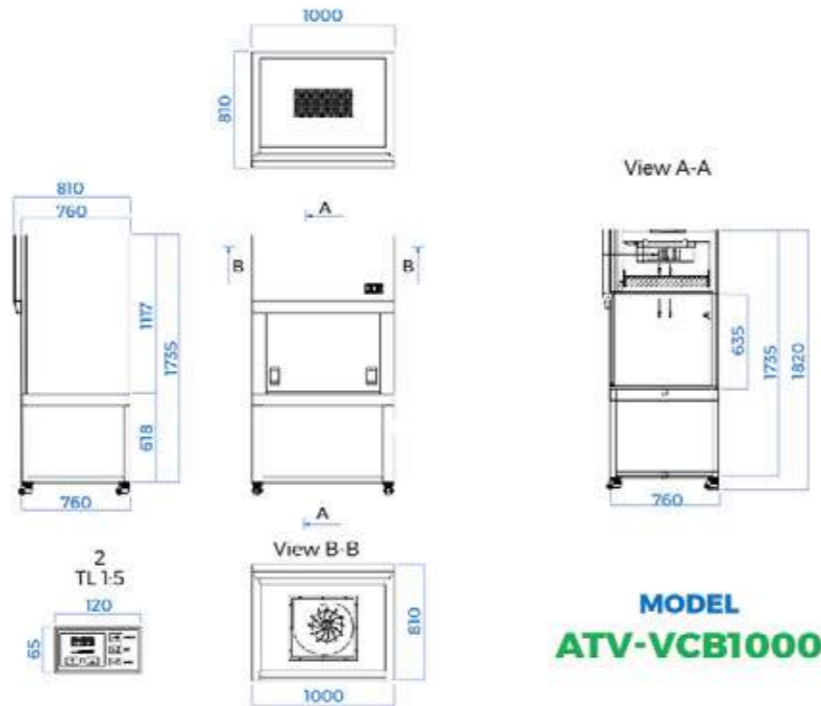

MODULE FORM AND SPECIFICATION

HORIZONTAL LAMINAR CLEAN BENCH

MODEL	ATV-HCB1000	ATV-HCB1400	ATV-HCB1600
Type	Single	Double	Double
Overall dimensions (W x D x H)	1060 x 800 x 1690 (mm)	1460 x 800 x 1690 (mm)	1660 x 800 x 1690 (mm)
Working dimensions (W x D x H)	980 x 500 x 640 (mm)	1400 x 500 x 640 (mm)	1600 x 500 x 640 (mm)
Airflow rate	0.3 - 0.5 (m/s)		
Materials	Frame: Electrostatic powder coated steel, bright grey color		
	Working table: SUS 304		
	Window: Toughened glass, T = 4 mm		
Coarse filter	Polyester, washable		
HEPA filter	Efficiency: 99.99% (@≥ 0.3 micron)		
Noise level	<60 dB		
Florescent lamp	21W x 1	28W x 1	28W x 1
UV lamp	20W x 1	30W x 1	30W x 1
Castor	Universal		
Power supply	220V/50Hz		
Auxiliary parts	Florescent lamp, UV lamp, stands, 2 sockets		

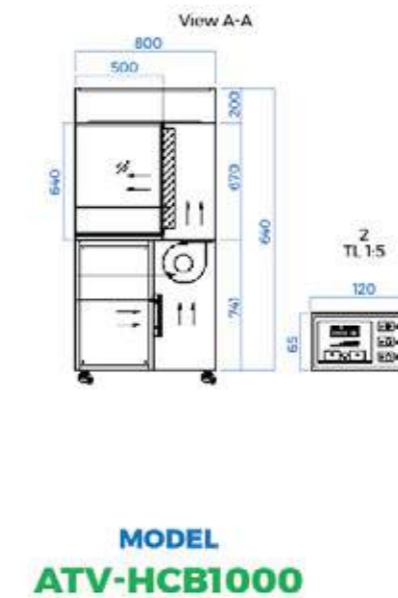
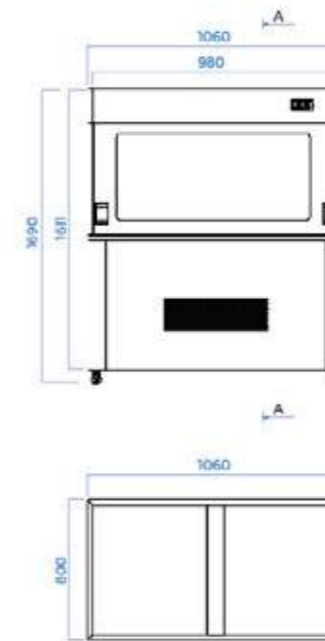

CHEMICALS STORAGE CABINET INTRODUCTION

CHEMICALS STORAGE CABINET (CSC) is used to contain and preserve toxic solvents and chemicals, and protect the user from the harmful effects of these substances during their storage in the laboratory.



MODEL WITHOUT ACTIVATED CARBON FILTER

ATV-CSC-2-900

ATV-CSC-2-1200

ATV-CSC-2-1500

MODEL WITH ACTIVATED CARBON FILTER

ATV-BFH-1200

ATV-BFH-1500

ATV-BFH-1800

MODEL DESCRIPTION

ATV - BFH - 1200

Base on outside width

-900: 1000mm

-1200: 1300mm

-1500: 1400mm

-1800: 1600mm

Base on with or without Activated Carbon Filter

- BFH: Without Activated Carbon Filter

- CSC-2: With Activated Carbon Filter

AIRTECH THE LONG

COMPONENT



FRAME MATERIAL: The whole structure is made from full plate iron 1.2mm in thickness and processed by CNC machine, preventing the door from being rippled from welding after electrostatic powder coating.



DOORS: 04 doors open independently, and glass frames are uniformly bevelled by CNC machine.



TEMPERED GLASS: is a safety glass which increases the surface tension, increase the bearing capacity, impact resistance, high load and crack resistance.



AIR FILTER: Perforated panels embedded to the insides of the cabinet help uniformly distribute the air current while the fan is operating.

MODULE FORM AND SPECIFICATION

CHEMICALS STORAGE CABINET WITHOUT ACTIVATED CARBON FILTER

MODEL	ATV - CSC - 2 - 900	ATV - CSC - 2 - 1200	ATV - CSC - 2 - 1500
Overall dimensions (W x D x H)	900 x 550 x 1800 (mm)	1200 x 550 x 1800 (mm)	1600 x 550 x 1800 (mm)
Working dimensions (W x D x H)	850 x 500 x 1600 (mm)	1150 x 500 x 1600 (mm)	1450 x 500 x 1600 (mm)
No. of shelves	4		
No. of drawers for each shelf	3		
Frame material	Electrostatic powder coated steel		
Door material	Powder coated steel & Toughened glass 4mm thick		
Drawers	2		
Light	LED 9W		
Power supply	220V/50Hz		

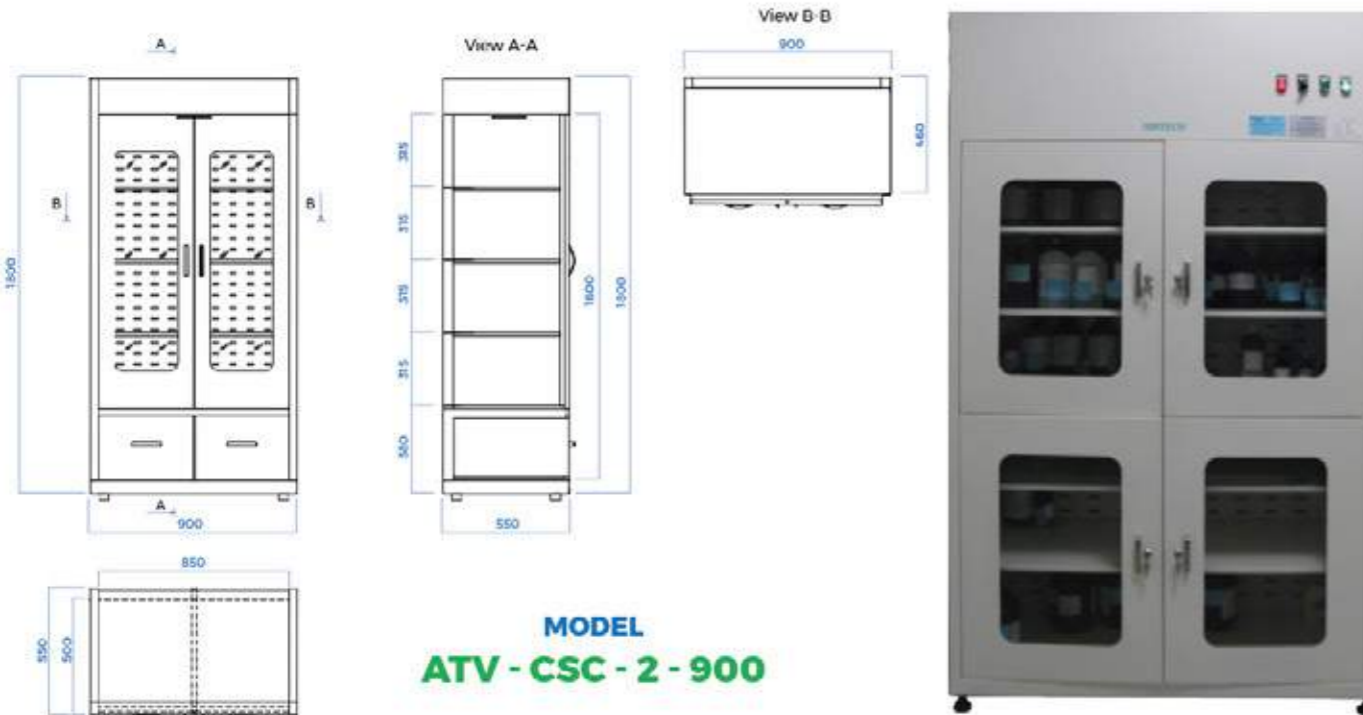

MODULE FORM AND SPECIFICATION

CHEMICAL STORAGE CABINET WITH ACTIVATED CARBON FILTER

MODEL	ATV - BFH1200	ATV - BFH1500	ATV - BFH1800
Overall dimensions (W x D x H)	1200 x 900 x 2200 (mm)	1500 x 900 x 2200 (mm)	1800 x 900 x 2200 (mm)
Working dimensions (W x D x H)	1020 x 700 x 1700 (mm)	1320 x 700 x 1700 (mm)	1620 x 700 x 1700 (mm)
No. of shelves	4		
No. of drawers for each shelf	8		
Frame material	Electrostatic powder coated steel		
Door material	Toughened glass 5 mm thick and steel		
Filter	Carbon filter		
Noise level	<65 dB		
Fan	Yes		
Power supply	220V/50Hz		

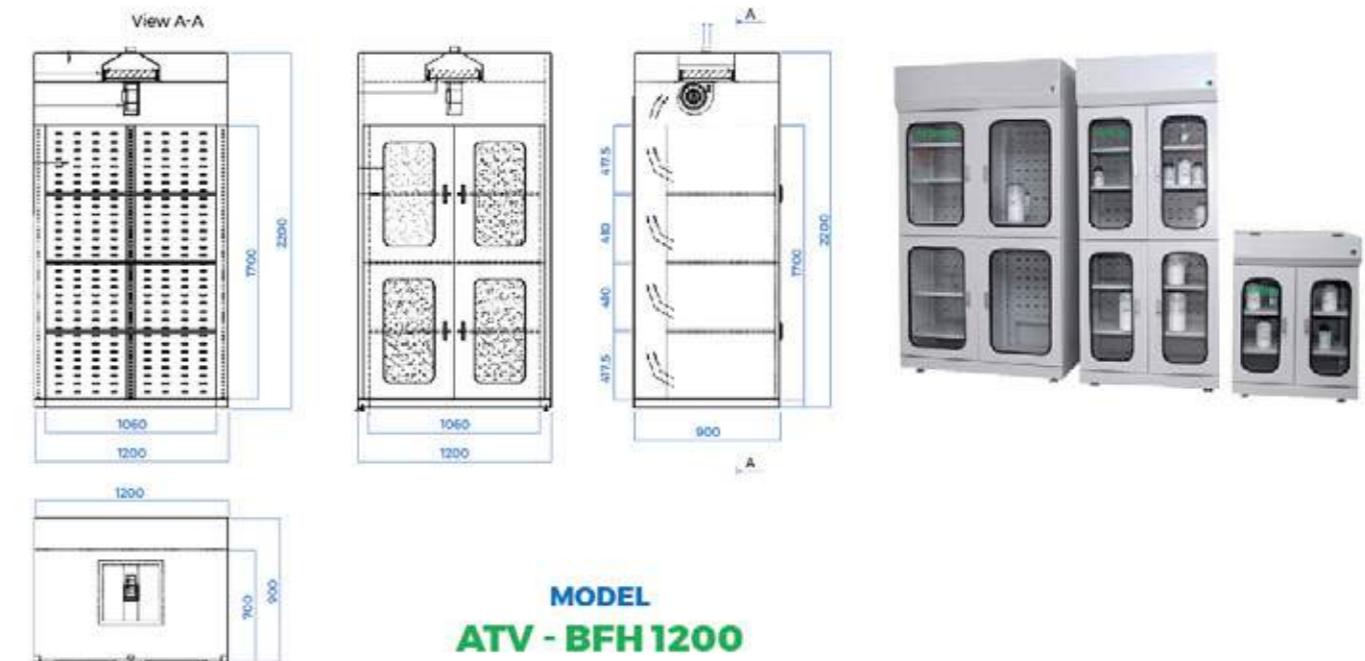

FUME HOOD INTRODUCTION

FUME HOODS are toxic removal and workplace cleansing equipments, designed to protect the user from hazardous or toxic fumes and vapors generated on the working surface of high-risk working environments such as industrial laboratories, pharmaceuticals or chemicals manufacturing centers.



MODEL SPECIFICATION

ATV - FH 1000

ATV - FH 1200

MODEL SPECIFICATION

ATV - FH 1500

ATV - FH 1800

Base on outside width

-900: 1000mm

-1200: 1300mm

-1500: 1400mm

-1800: 1600mm

ATV - FH - 1200

FUME HOODS

AIRTECH VIET NAM

COMPONENT



FRAME MATERIAL: is made from high quality steel with electrostatic powder coating and the insides are made from SUS304 Inox, creating a steady, sharp and aesthetical design. The working table and working chamber are made of laboratories-dedicated phenol panels, which are anti-rust, anti-corrosion, chemicals enduring and easy to clean.

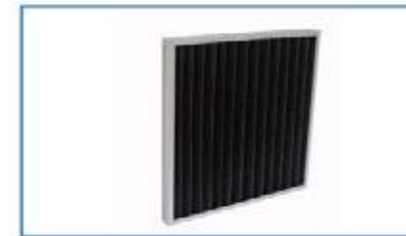

FILTER MEMBRANE WITH ACTIVATED CARBON: embedded on the top of the hood can filter the polluted air before emitting to the outside in order to protect the environment and human safety.



ADVANCED FAN SYSTEM: The motor has a small design, conserves electricity, and has a self-cooling feature. All rotating components are balancedly designed, thus decreases noise and vibration levels.



TOUGHENED GLASS WINDOW: is designed with a counterpoise system with free stopping point, ensuring easy vertical sliding. Protective glass is 5mm thick, highly stable, and convenient when closing to sterilize the working chamber.



CONTROL PANEL: Innovative and easy to clean micro-processing control system includes various features including fan control, lighting, a spare socket and UV lamp(s).



PP SINK AND FAUCET: Imported PP integrate molded sink with acid and alkali resistance. The water faucet nozzles are made of high quality copper and coated in epoxy resin powder, specially designed for use in labs.

MODULE FORM AND SPECIFICATION

MODEL		ATV - FH1000	ATV - FH1200
Total dimensions (R x S x C)		1000 x 800 x 1900 (mm)	1200 x 850 x 1900 (mm)
Working dimensions (R x S x C)		800 x 620 x 720 (mm)	1000 x 620 x 720 (mm)
Structure	Case	Electrostatic powder coated steel	
	Stands	Electrostatic powder coated steel	
Working table surface		Phenolic According to user's requirements	
Door	Structure	Toughened glass	
	Sliding (up and down)	Manually	
Power supply		220VAC/50HZ/1Phase/200W	
Fan		200W x 01 (unit)	
Air velocity		0.5 m/s (100fpm)	
Sink and Faucet		1 Set	
Noise 1 meter away from the equipment		62 - 65 (dBA)	
Lighting	Led 600mm	18W x 01 (unit)	
UV lamp(s)	600mm	According to user's requirements	
Deodorizing carbon filter		400 x 400 x 50 (mm) x 01 (unit)	
Other specifications		According to user's requirements	

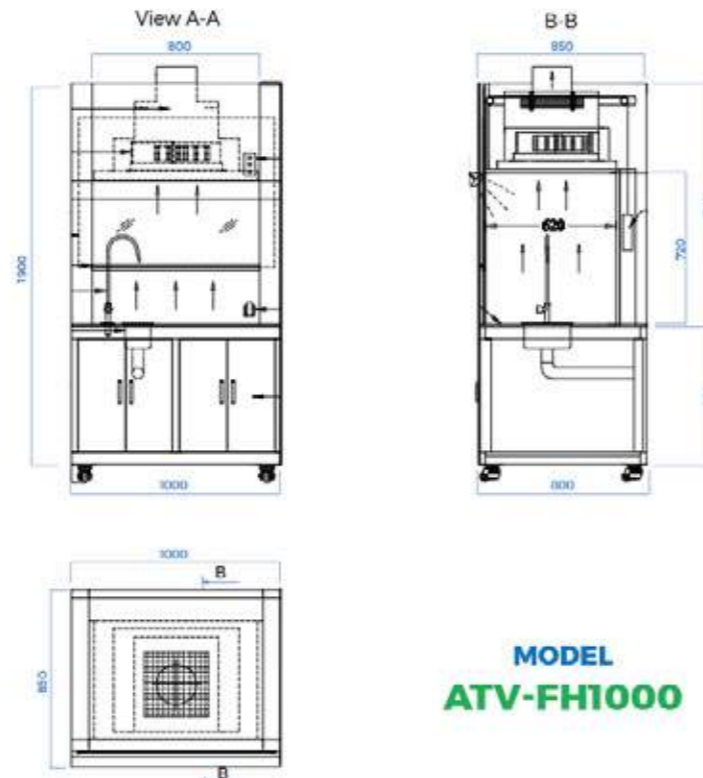

MODULE FORM AND SPECIFICATION

MODEL		ATV - FH1500	ATV - FH1800
Total dimensions (R x S x C)		1500 x 850 x 1900 (mm)	1800 x 850 x 1900 (mm)
Working dimensions (R x S x C)		1300 x 620 x 720 (mm)	1600 x 620 x 720 (mm)
Structure	Case	Electrostatic powder coated steel	
	Stands	Electrostatic powder coated steel	
Working table surface		Phenolic According to user's requirements	
Door	Structure	Toughened glass	
	Sliding (up and down)	Manually	
Power supply		220VAC/50HZ/1Phase/200W	
Fan		200W x 02 (unit)	
Air velocity		0.5 m/s (100fpm)	
Sink and Faucet		1 Set	
Noise 1 meter away from the equipment		62 - 65 (dBA)	
Lighting	Led 600mm	36W x 01 (unit)	
UV lamp(s)	600mm	According to user's requirements	
Deodorizing carbon filter		400 x 400 x 50 (mm) x 01 (unit)	
Other specifications		According to user's requirements	

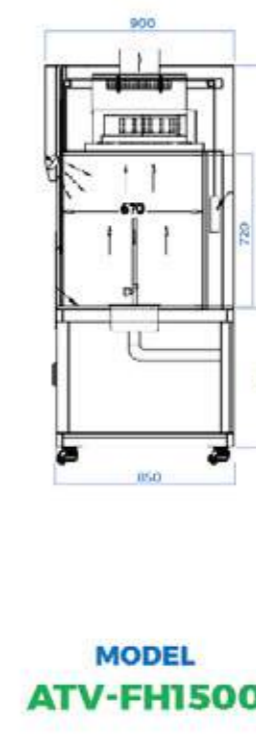
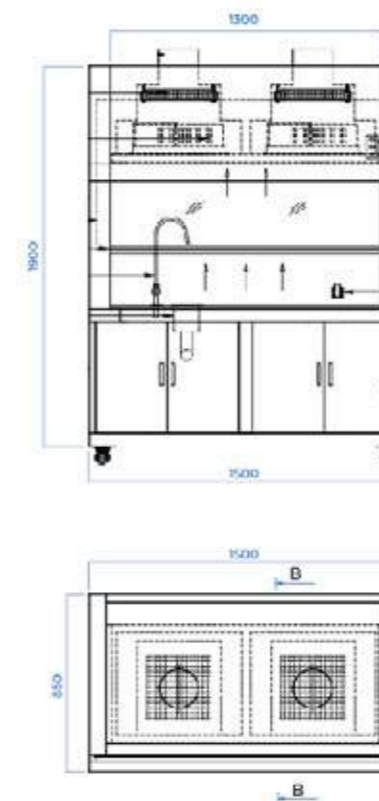

LAMINAR AIR FLOW CABIN



The Laminar Air Flow cabin is to meet the growing need for essential protection of staff, animals and ent during handling procedures. Within the LAF cabin, cage changing or other animal procedures may betly and safely performed under sterile conditions.

THE BIN

The Labbines ergonomically, correct working conditions with optimal safety protection for animals, staff and environmcreased use of valuable transgenic animals imposes strict SOPson staff. Aseptic procedures should always be followed the status of the animals. Increasing numbers of people suffer from work related allergies (L.A.A). To achieve high levetion and maintain pleasant working conditions, all the items involved in specific procedures should be kept to hand wintected LAF cabin e.g, dirty cages clean cages, new bedding, fresh water, diec, etc.

CAGE

A time safe procedure

Whether ventilated Scantainer with open cages, the ventilater with individually ventilated filtertop cages or anorth HVC systems; the rack is simply wheeled to the LAF cab is aligned to the front of the LAF cabin. It is novd easy to carry out cage changing safety under sterile corhour the awkward restrictions that a LAF bench imposesdures. It is also use for example, a Scantainer with open non-filtertop no cross-contamination risk between cabins as longdures rake place under the LAF cabin.



SAFE

Animals environment

- Prols from possible contamination
- Pre-contamination between cages
- Prerom exposure to allergens (L.A.A)
- Pramdngs: Eliminates spread of dust pagens and pathegens back into the roanimal handling and cage stacking.

TEST

Upon ime following parameters are tested:

- Ele
- Fu
- Air downflow area
- S
- Dgest (photometer test)

A test wich each LAF-cabim

ERGONOMICS

A spacious unit

- Large working area allows staff to work swiftly accurately and safely in an ergonomically correct way
- Staff are unrestricted by limited work space and openings (as in a cage changing station)
- Plenty of room for auxiliary equipment needed to carry out the various procedures
- The LAF cabin is easy to keep clean as all surfaces are smooth and easily accessible. The pre-filter is fitted at floor level and easily changed.

TEAL SPECIFICATIONS

The is constructed around a basic module.

Depcour actual use and where the unit is to be installed, it can be equipped various options. The LAF cabin is besped to meet your specific requirements by the addition of the various available options: Perforated table top, wastg, electric power points, special lighting, gas supply, extra sound insulation, weighing scales, fixed solid side-walls transparent plastic strip curtains, etc.

It is at the air is laminar over the whole downflow area. This is obtained by using our specially designed laminator that entire downflow area. This specifically ensures that there are no "dead" areas or turbulence. The average air velooow is specified as 0.45 m/s \pm 0.05 m/s (all measured points are within \pm 20% of this average) in the entire worl this is essential to achieve sterile working conditions.

A flotomatically adjusts the downflow velocity to ensure compliance with the specified velocity at all times.

Soft-ating panel: Full speed-half speed-full light-energy emergency stop-visual downflow alarm.

HEPA 14 according to DIN 24183-24185 or H14 according to EN 1822, i.e. 99.995% efficiency against most penericles size (MPPS). Class 100 according to Federal Standard 209D, 1988 (Sterile Working Conditions) or Clasding to Federal Standard 209E, 1992)

HOW DOES THE LAF CABIN WORK?

Inside the LAF cabin all air is forced downwards through a HEPA filter. The HEPA filtered downflow

VARIOUS APPLICATIONS

The LAF cabin is ideal as:

- cage changing area
- cage cleaning our area
- reception intake area for new animals
- washing area
- weighing of animals
- blood sampling
- minor operations
- handling of larger animals
- autoclaving area

air passes through the perforated working table and is then extracted through the pre-filter as floor level. The air is partly re-circulated and partly exhausted. The exhaust air ensures that the LAF cabin is a "containment" area.

For optimal safety it is extremely important that the airflow is laminar, and that there are no "dead" areas where turbulence could occur. Our specially designed laminator ensures an extremely uniform and laminar airflow. Air is pulled into the unit through pre-filter. Approx. 1620 m³/hour per m³ of air is forced into the pressure plenum by the ventilartor and through the HEPA filter.

Approx. 80% of air is lead through the main HEPA filter. 20% is lead through the exhaust HEPA filter. he laminator is located below the main HEPA filter.

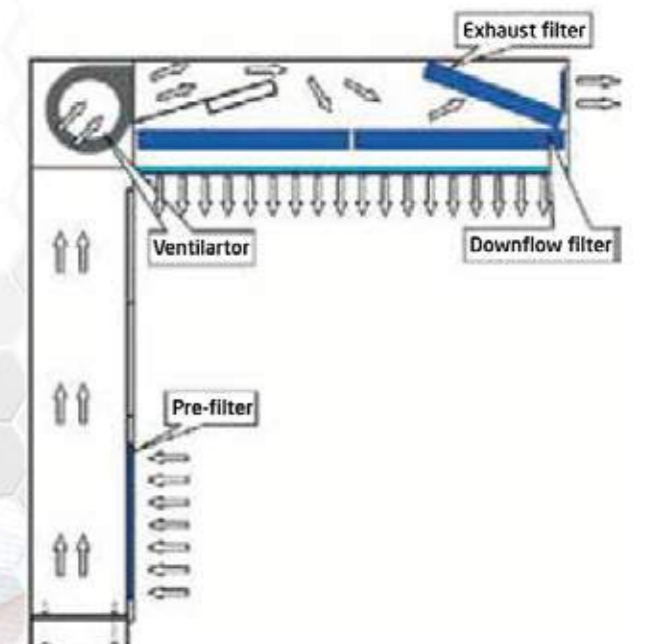

MODULE FORM AND SPECIFICATION

LAMINAR AIR FLOW

MODEL	ATV - AMR 2030S
Cleanliness	HEPA: ISO5 (Class 100) / ULPA: ISO4 (Class 10)
Filtration Efficiency	HEPA: $\geq 99.995\%$ @0.3 μm / ULPA: $\geq 99.999\%$ @0.12 μm
Downflow velocity	0,35-0,54(m/s)
Inside	W1930xD1270xH1830 (mm)
Outside	W2030xD1965xH2105 (mm)
Material	3 walls of Laminar Air Flow are made of SUS 304, T=1.2mm, the font use transparent PE curtain
Power Supply	380V - 50Hz
Pressure gauge: 0-500Pa	03Pcs
LED light 40W	03Pcs
DOP test	03Pcs

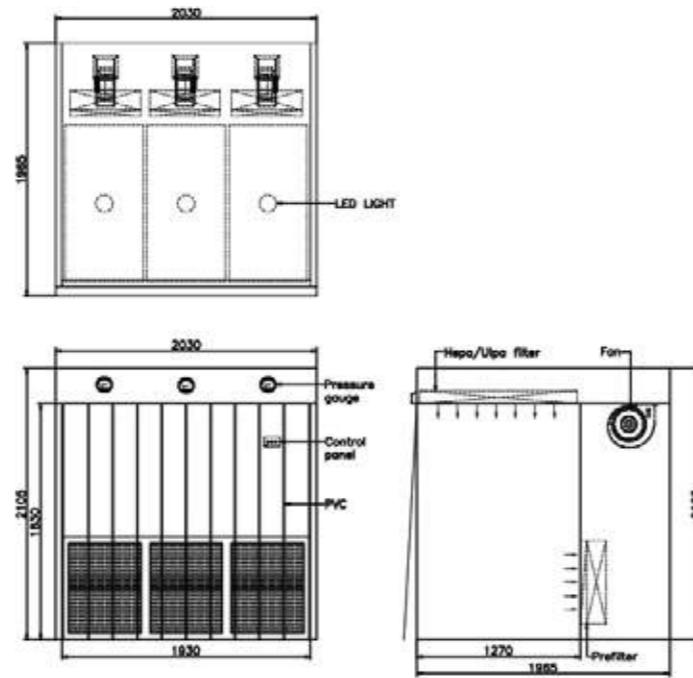

MODULE FORM AND SPECIFICATION

LAMINAR AIR FLOW

MODEL	ATV - AMR 1390S
Cleanliness	HEPA: ISO5 (Class 100) / ULPA: ISO4 (Class 10)
Filtration Efficiency	HEPA: $\geq 99.995\%$ @0.3 μm / ULPA: $\geq 99.999\%$ @0.12 μm
Downflow velocity	0,35-0,54(m/s)
Inside	W1290xD1270xH1830 (mm)
Outside	W1390xD1965xH2105 (mm)
Material	3 walls of Laminar Air Flow are made of SUS 304, T=1.2mm, the font use transparent PE curtain
Power Supply	380V - 50Hz
Pressure gauge: 0-500Pa	02Pcs
LED light 40W	02Pcs
DOP test	03Pcs

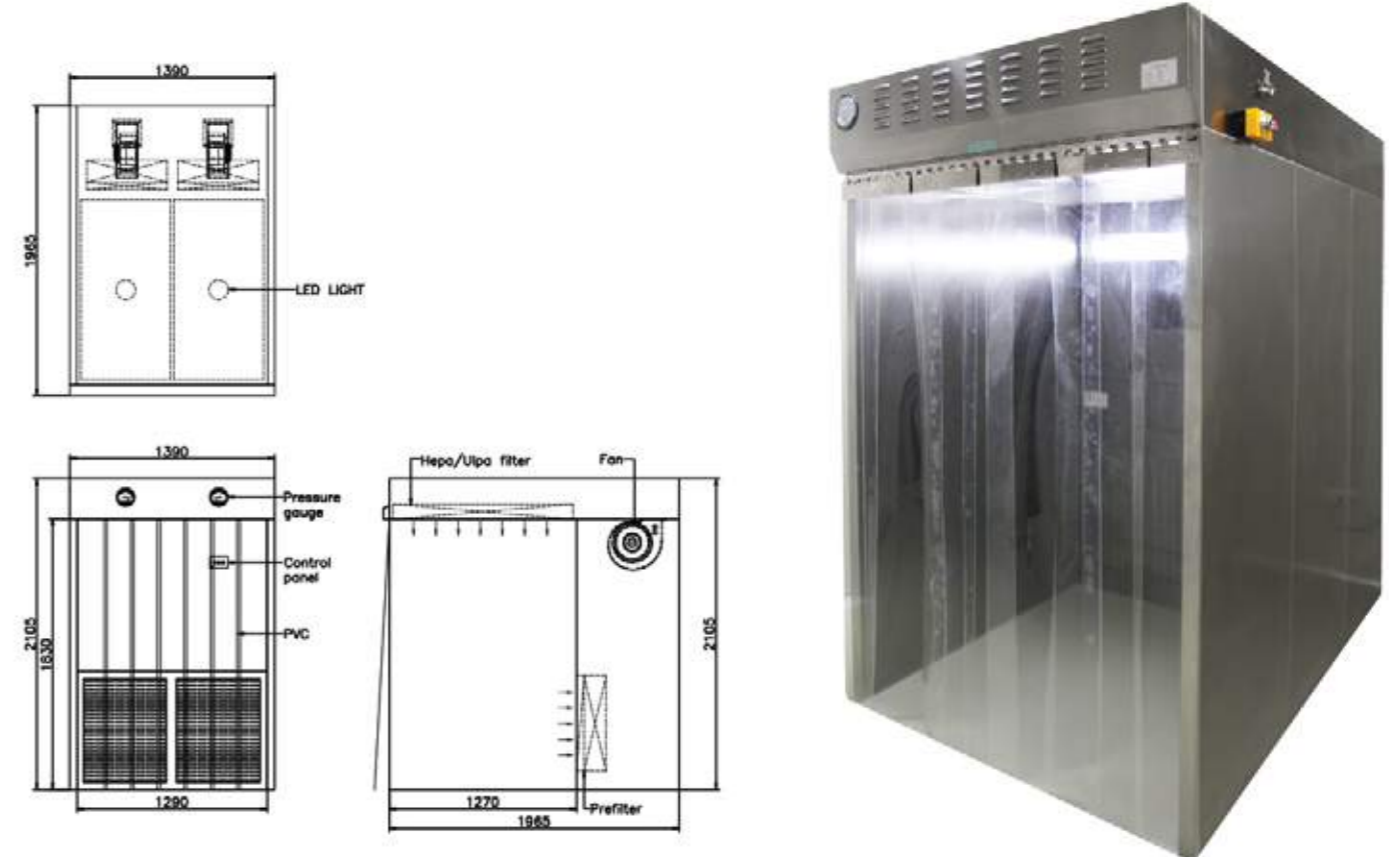

LAB FURNITURE



1. WORK TOP

- The work top is made of imported phenolic resin laminate with full CO, CQ
- Thickness options: 12.7 mm/19mm/20mm/25mm.
- Color options: Black/ Dark Grey/ Light Grey/ Light Blue / Green/ White
- The work top surface is scratch resistant, conductive resistance so that it is suitable for machine and equipment setting up and for users to direct operate on it
- The chemical resistant laminate is HPL for the substrate, surface specially treated (plus a layer of high temperature wear resistance, acid and alkali chemical film), so that the laminate has superior physical and chemical resistance corrosion features, limits the growing up of micro-organisms, is specially designed for laboratory bench
- The other choices for material of work top: Epoxy Resin/ Phenolic Resin/Stainless Steel/Ceramic

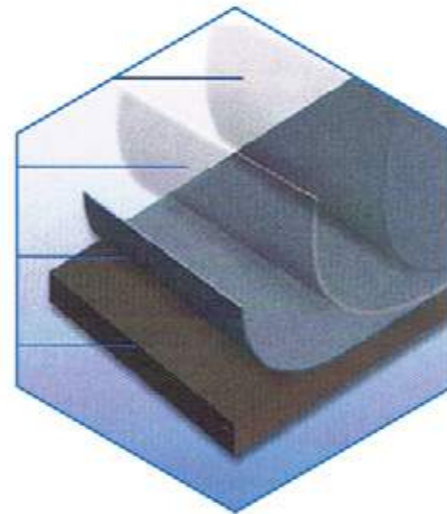

2. FRAME

- The frame is module structure of powder coated steel or SUS304 bars jointed together by industrial connection pieces
- Bench standings are made of powder coated steel or SUS304 40*80 x 1.4mm shaped bars, solid welded together, the bench legs are covered by anti-moisture and chemical resistance PA plastic cap
- The legs are installed levellers for height adjustment of bench or buffers for antivibration
- Three-layer reagan rack shelf
- + Dimension: ...x300x1200mm
- + The columns are made of powder coated steel of 40*80x1.4mm Stainless steel shaped bars with 10mm diameter SUS304 support bracket
- The shelf surface made of tempered glass 8mm



3. PP CHEMICAL RESISTANT SINK SPECIALIZED FOR LAB

- Colour: Black
- Material: High quality PP with high physical and chemical resistance
- Internal dimension: 490x390x290mm
- External dimension: 550x450x310mm



4. 3-WAY WATER TAP

- Material :The water tap is made of high quality copper and coated in epoxy resin powder, specially designed for use in labs.
- Valve: High quality PP, valve core is from porcelain ceramic with high durability: 500.000 using times
- The tap can stand high water pressure to 25 Bar
- Nozzles can be uninstalled, easily cleaned



5. PEGBOARD

- The material of peadboard is SUS304 that can bear nearly all kinds of chemical
- Hanging bars: PP material, flexible, easily for place and quantity adjustment. The bars can be taken off for clean purpose

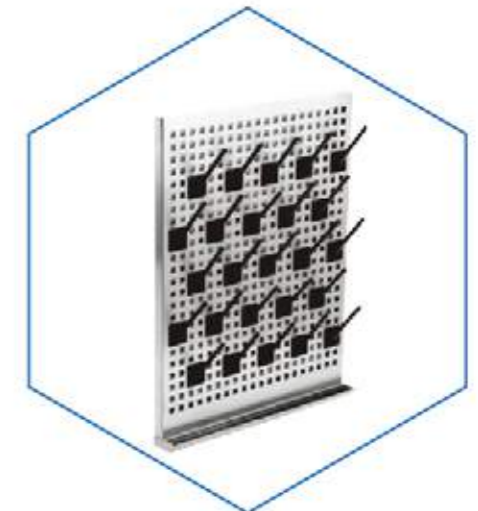

MODULE FORM AND SPECIFICATION

CENTRAL LAB BENCH

MODEL AND ITEM	ATV - BTN-TT-3600X750X800	ATV - BTN-TT-3600X750X800/1500
Manufacturer	AIRTECH THE LONG	
Dimensions	L3600xD1500xH800(mm)	L3600xD1500xH800/1500(mm)
Bench top surface	Bench top surface is made of full size (3600*1500mm) specialized Chemsurf Phenolic resin laminate from Wilsonart USA brand manufactured in China or Thailand with full CO and CQ	
Bench top color	Black / Light gray	
Bench top thickness	12,7(mm)/19(mm)	
Bench frame	Bench standings are made of powder coated steel or SUS304 40*80 x 1.4mm shaped bars, solid welded together. Bench legs are covered by anti-moisture and chemical resistant PA plastic cap. Leveling feet can adjust the height of bench with a range of 25mm, and prevent scratch on the ground floor. Bench standings are combined with cabinets.	
Two-layer reagan rack shelf	None	Dimensions : 3000*300*800 (mm) Surface shelves are made of 8mm thick toughened glass, and banisters are made from SUS 304 inox bobbins φ10mm
Cabinet	06 Pcs	06 Pcs



MODULE FORM AND SPECIFICATION

WALL LAB BENCH

MODEL AND ITEM	ATV - BTN-AT-1200X750X800	ATV - BTN-GOC-1 000X1000X800
Manufacturer	AIRTECH THE LONG	
Dimensions	L1200xD750xH800(mm)	L1000xD1000xH800(mm)
Bench top surface	Bench top surface is made of full size (3600*1500mm) specialized Chemsurf Phenolic resin laminate from Wilsonart USA brand manufactured in China or Thailand with full CO and CQ	
Bench top color	Black / Light gray	
Bench top thickness	12,7(mm)/19(mm)	
Bench frame	Bench standings are made of powder coated steel or SUS304 40*80 x 1.4mm shaped bars, solid welded together. Bench legs are covered by anti-moisture and chemical resistant PA plastic cap. Leveling feet can adjust the height of bench with a range of 25mm, and prevent scratch on the ground floor. Bench standings are combined with cabinets.	
Two-layer reagan rack shelf	None	None
Cabinet	01 Pcs	None

