

# AP&T®

## AP-AB1113 Anti-shock AC Ion Bar

### AP&T



### Product Overview

The AP-AB1113 ion bar is a rod-type static elimination device developed by AP&T to eliminate static electricity on the surface of objects.

The AP-AB1113 ion bar adopts the power frequency AC high voltage, acts on the special emitter electrode through the impedance coupling device, ionizes the air molecules, generates positive and negative ions, and delivers to the surface of the static elimination object, neutralizing the positive and negative electrostatic charges, achieving high efficiency. , the purpose of reliable elimination of static electricity.

Can be widely used in film, printing, plastic, textile and other industries.

◆Product Features

1. It is a rod type and horizontal type active static eliminator.
- 2, the bar is small, saving installation space.
3. High voltage, micro current ( $\mu\text{A}$  level) working state.
4. Fast power-off capability.
- 5, tungsten electrode, long-term ionization ability.
- 6, with anti-shock function, to avoid accidental touch caused by human body injury.
- 7,Special strip-shaped notches on the back of the rod, the mounting bolts can be moved.

**AP&T**  
安平静电



◆Performance parameter

Model	AP-AB1113
Working voltage	AC7000V
Power	20W
Ion emission	Power frequency communication
Transmitting electrode	Tungsten
Discharge structure	Resistance coupling
Discharge range	L*W*H (150mm→3000mm) *300mm*100mm
Installation distance	30→100mm
Ion balance	$\leq \pm 150\text{V} $ (AVE)
Dissipation speed	$\leq 1.0\text{S}$ (working distance 100mm)
Operating temperature	0°C - 50°C

Working humidity	<70%
Dimensions	L*W*H (150mm→3000mm) *21mm*32.4mm
Rod material	Flame retardant PVC, AL
Mounting accessories	M4×20 hex mounting bolts
Supporting power supply	AP-AY1504/ AP-AY2504
High-voltage cable length	2.5m (can be customized according to requirements, the longest size is 10m)
Warranty period	1 year
Certificate	CE

◆ **Working way**

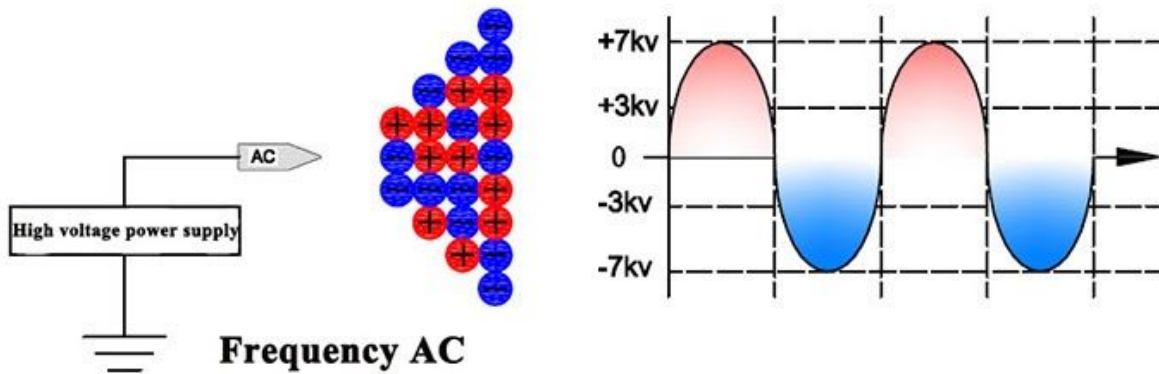

◆ **Eliminate static electricity effects**

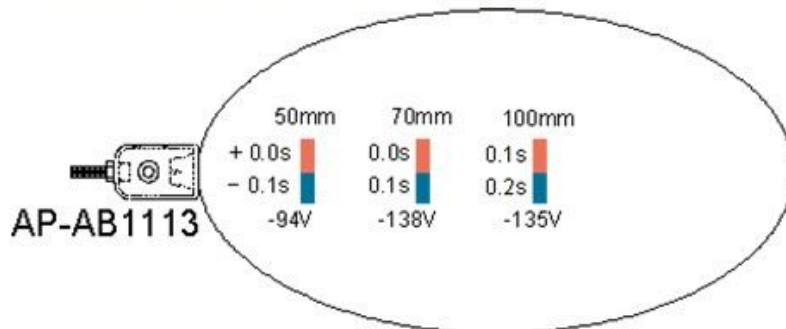

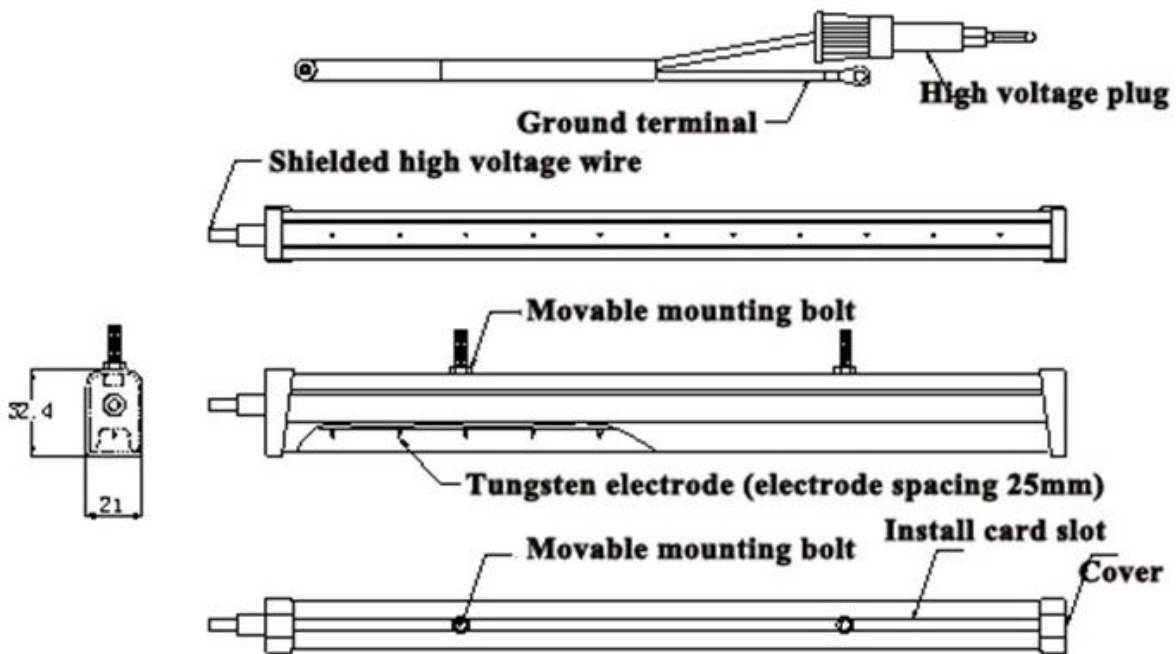

#### Security warning

1. Please read the instruction manual carefully before installing and using the device.
2. The whole set of equipment must be reliably grounded during use, and the grounding resistance is less than 4 ohms; otherwise, the ion rod may be abnormal or even damaged.
3. It is not advisable to use the device in a >70% humidity environment.
4. It is strictly forbidden to use this equipment in flammable and explosive environments.
5. It is strictly forbidden to disassemble the product without authorization. Internal maintenance and repair must be carried out by professionals.
6. The product is strictly prohibited from touching water stains, otherwise abnormalities may occur, resulting in electric shock or fire.
7. Check or replace the product, you must turn off the power, otherwise it may cause electric shock or fire.
8. The product is designed for static elimination. It is strictly forbidden to use for other purposes. Any abnormal use may cause machine malfunction, electric shock, fire and other hidden dangers.
9. Do not touch the electrode needle when the power is on, otherwise it may cause malfunction and electric shock.
10. The discharge needle is a sharp metal object, please use it with care.
11. Before powering on the product, please check the specifications of the power supply. Any power supply that does not meet the specifications will cause damage or even malfunction.
12. Please check the power cord of the product regularly. If it is damaged, please replace it immediately, otherwise it will cause problems such as leakage and abnormal operation.

## Use and installation

### 1, installation and use instructions:

- (1) Select the best power-off position and install the rod and the supporting high-voltage power supply firmly.
- (2) Insert the high voltage plug of the rod into the high voltage output connection of the high voltage power supply.
- (3) Connect the ground terminal of the rod to the high voltage power supply ground stud.
- (4) Turn on the power switch, the switch indicator light shows the power supply, and the positive and negative ions will be generated at the electrode needle to neutralize the static electricity on the surface of the object.

### 2. Outline structure diagram:

### 3. Schematic diagram of installation method:

### 4, technical tips.

- (1) When using an ion bar, it should be placed in a working area where static electricity is removed. (It is preferably about 30~100mm from the surface of the object to be statically removed.) The mounting angle should be perpendicular to the surface of the charged body.
- (2) The ion bar should be placed at least 3cm away from the metal conductor and the metal grounding body. The rod must be reliably connected to the grounding wire.
- (3) The surface of the ion bar is not allowed to cover other objects.
- (4) It is advisable to install two ion bars side by side at intervals of 10 cm or more, and it is more suitable to be more than 20 cm from obstacles such as walls.

## ◆ Installation method

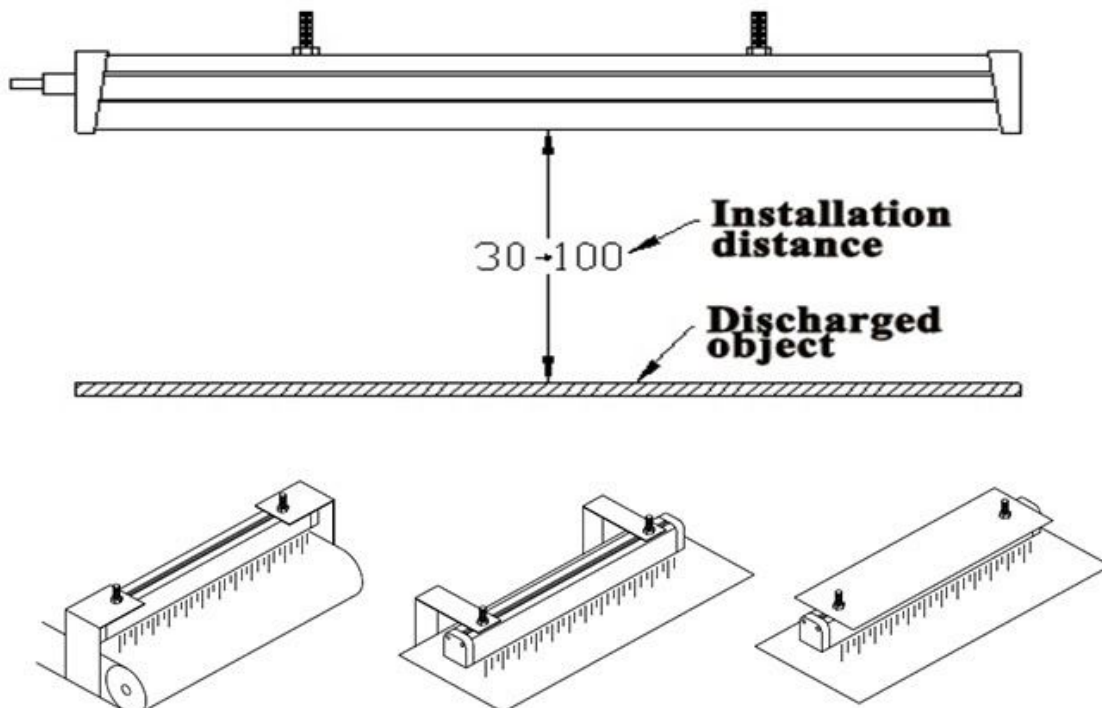

### (5) Troubleshooting solution:

NO.	Problem	Possible cause	Solution
-----	---------	----------------	----------

1	The power removal performance is significantly reduced.	The discharge needle is contaminated and damaged.	Clean or replace the ion bar.
		The ion bar is not properly positioned.	Confirm the best installation position.
2	Reduced static performance.	Conductors or other ion bars around the ion bar.	Remove (dynamic) conductors or other ion bars.
3	Cannot be discharged.	High voltage cable is damaged.	Return to factory for repair.
		Ion bar insulation damage	Return to factory for repair.
		Poor grounding / no grounding	Check the electrical grounding of the ion bar and plant equipment
4	Product burnout	Ion bar insulation damage	Return to factory for repair.

#### Maintenance

1. In order to ensure the good performance of the product, it should be cleaned and maintained in time according to the use environment and the required static protection requirements. That is, use an electrostatic brush, a dust-free cotton swab, a dust-free cloth, and remove the anhydrous alcohol. The performance of the carbon deposits on the electrodes and rods is significantly improved. note:

A. It must be operated 10 minutes after the power is turned off.

B. During the use of the ion bar, when there is dust or white matter on the tip of the needle, it must be cleaned. When the brush is not used to meet the cleaning requirements, use a dust-free cotton swab to remove anhydrous alcohol.

C. After cleaning, the alcohol must be completely evaporated and then energized. Do not use any other organic solvent to clean the rod.

2. It is found that the ion bar appears to be burnt, it should be stopped, and it should be inspected and repaired by professional maintenance personnel. It can be used after the electrical performance index is normal.