

AP&T[®]

AC 4.6KV Anti Static Device Air Nozzle Static
Dissipative Snake CE Certificate



AP&T[®]



Features

- 1, Exquisite appearance, simple structure, easy to move and install.
- 2, Metal ring switch with flash light enables user to monitor working status of the product.
- 3, HV alarm by beeping and LED.
- 4, Inductive current with high safety performance.
- 5, Fast discharge speed, low ion balance and high safety performance.
- 6, Optional photoelectric inductive switch to control airflow instead of manual operation.
- 7, All in one design saves space.
- 8, Change the air outlet freely according to the size of the product

Specification

Input voltage	220V/50Hz or 110V/60Hz
Output voltage	AC 4.6KV
Power	30W
Working distance	100—400mm
Ion balance	$\leq \pm 35V $
Discharge	$\leq 2S$
Working temperature	0°C-50°C
Working humidity	<70%
Noise	<70dB
Net weight	Appr. 2.6kg(Photoelectric inductive switch excluded)
Net weight	Appr. 3kg(Photoelectric inductive switch excluded)
Gross weight	Appr. 3.3kg(Photoelectric inductive switch excluded)
Gross weight	Appr. 3.7kg(Photoelectric inductive switch excluded)
Medium used	Clean pressed air
Air connector	Φ8mm
Pipe length	525mm
Base box Dimension	163mm(L)*126mm(W)*90mm(H)
Dimension	163mm(L)*126mm(W)*700mm(H)
Housing material	Aluminum alloy
Cord length	1.8M



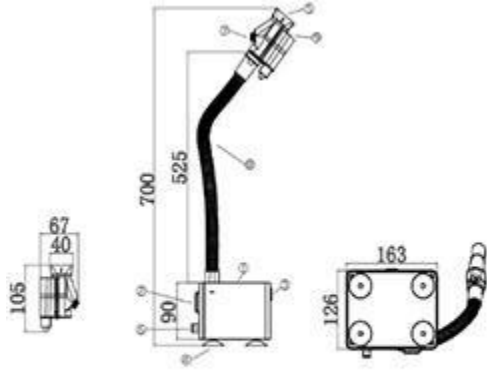

- 1.cabinet 2.power port 3.power switch 4.sucker pads
- 5.compressed air outlet 6.air source connector 7.governor valve
- 8.soft tube 9.optoelectronic switch

Our workshop

