



## AP-YV3302 electrostatic sensor



### Product Overview

#### I. Product Overview

AP-YV3302H electrostatic sensor is a detecting instrument developed and produced by Anping Company to detect the static voltage on the surface of an object with static electricity, which adopts the non-contact measurement technology to minimize the impact of the detecting instrument on the electrostatic field on the surface of the object and ensure the accuracy of measurement.

#### II. Scope of Application

It can be widely applied in the industries such as electronics, photoelectricity and plastics.

#### ◆Product Features

#### III. Product Features

1. With comfortable feel and beautiful appearance.
2. Detection distance can be selected via dial switch.
3. Wide detection potential range and high detection precision.

4. Alarm threshold can be set and red light alarm indicates exceeding threshold.
5. High-definition and all-dimensional LCD data display terminal.
6. Monitoring data can be transmitted to PC in real time.
7. Conformable for operation and convenient for use.

#### IV. Product Parameters and Technical Functions

##### 1. Performance parameters

##### 1). Technical specifications:

No.	Technical specifications	
1	Working voltage	DC8-24V
2	Working current	<20mA
3	Vibration	<1KHz
4	Noise	<5dB
5	Signal output	RS485
		NPN (Collector control, 24/100mA)
6	Communication distance	<500m
7	Alarm indication	Red light LED
8	Threshold setting	±100V (default)
9	Alarm range	±50→±5000V
10	Detection angle	<15°
11	Startup stand-by time	5s
12	Infrared control distance	1m

※ Due to the improvement and upgrading of the product, the specification and performance of the product may be changed; Subject to the real product and please understand that notice cannot be given in advance.

##### Prompts of operating technologies

2.1. During operation, align with the front LED of the product (the distance is not more than 1m), press the unlock key at first, then press the corresponding functional keys to set, and the red light flashes when the key is pressed.

2.2. During zeroing setting, the calibration plate should be much larger than the detection window of sensor, and the polar plate and sensor should be well grounded.

2.3. During the calibration operation, the calibration plate should be much larger than the detection window of sensor and the sensor should be well grounded.

2.4. There should be no shield between the sensor and the detected object; otherwise the accuracy of the detection result will be affected.

2.5. There should be no electrical equipment that may affect the sensor within the detection range of the sensor.

2.6. To accurately measure the charged object, the plane of the sensor detection window must be parallel to the surface of the detected object.

2.7. When the charged object is smaller than the calibration plate, the measured value will be smaller than the actual electrostatic value of the charged object.

2.8. When the charged object is larger than the calibration plate, the measured value will be larger than the actual electrostatic value of the charged object.

2.9. Do not set zero in electrostatic charge state or in the electrostatic measurement process (non-static calibration process); if zero clearing is made during the electrostatic test, the displayed electrostatic value will be zero.

2.10. Influence of temperature and humidity on electrostatic detection:

The lower the temperature is, the smaller the humidity is, the less water is contained in the space, and the more easily the surrounding object triboelectric and the greater the interference to the electrostatic detection is.

1) The higher the temperature is, the higher the humidity is, the more water is contained in the space, and the more active the movement of water molecules is, which is easy to produce corona or spark discharge to the calibration device and the greater the influence on the uniform electric field generated by the calibration device, the weaker the uniform electric field will be.

2) Under the same humidity, the lower the temperature is, the less water is contained in the space, and the more easily the surrounding object triboelectric and the greater the influence on the electrostatic detection is.

Therefore, during electrostatic calibration/detection, the environmental temperature and humidity should be clearly indicated during calibration/detection.

2.11. Due to the existence of the cosmic rays and micro-radioactive substance in the environment as well as the use of various kinds of electrical equipment, there are inevitably more or less positive and negative ions in the detection space, which may also have certain impact on the detection results.

### 3. Display information of monitoring terminal

Working status: whether the sensor works normally and has alarm output.

Equipment address: display the address set by the sensor.

Detection distance: display the detection distance set by the sensor.

Threshold voltage: display the set safety (alarm) threshold of static voltage.

Real time voltage: display the static voltage value on the surface of the measured object.

Mechanical parameters

#### 4. Mechanical parameters

① Mechanical parameters of sensor:

Overall dimension:  $<44*33*85\text{mm}$  (L\*W\*H)

Net weight: about 49.7g

The overall dimension of sensor is shown as follows:

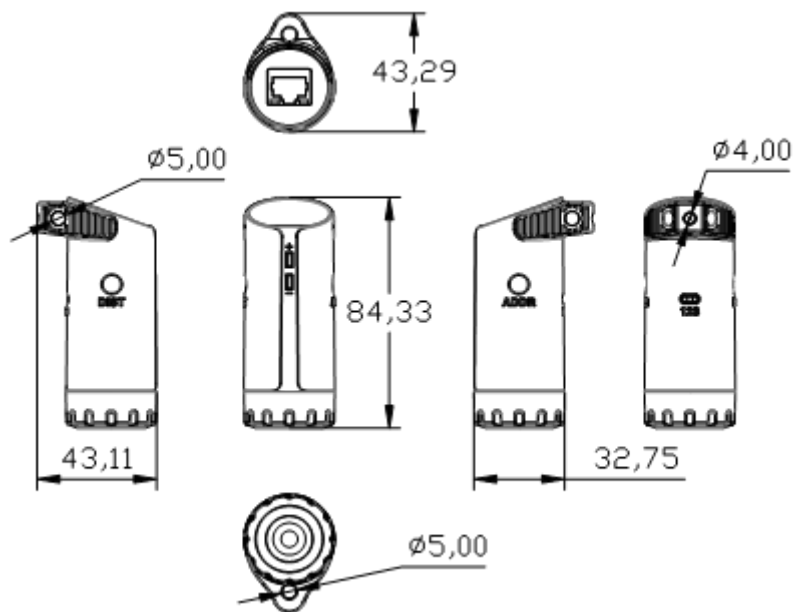

②Mechanical parameters of monitoring terminal

Overall dimension: 100\*120\*25mm (L\*W\*H)

Net weight of monitoring terminal: about 400g

The overall dimension of monitoring terminal is shown as follows:

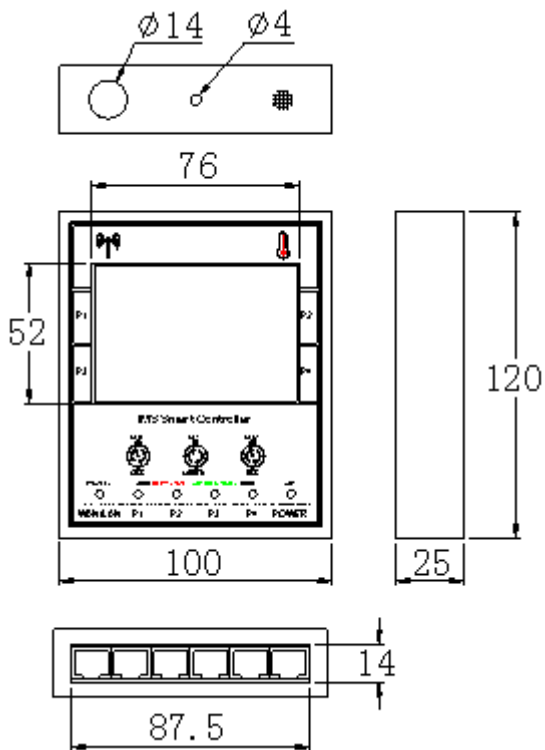

③Mechanical parameters of power adapter:

Overall dimension: 124\*61\*40mm (L\*W\*H)

Net weight of power adapter: about 234g

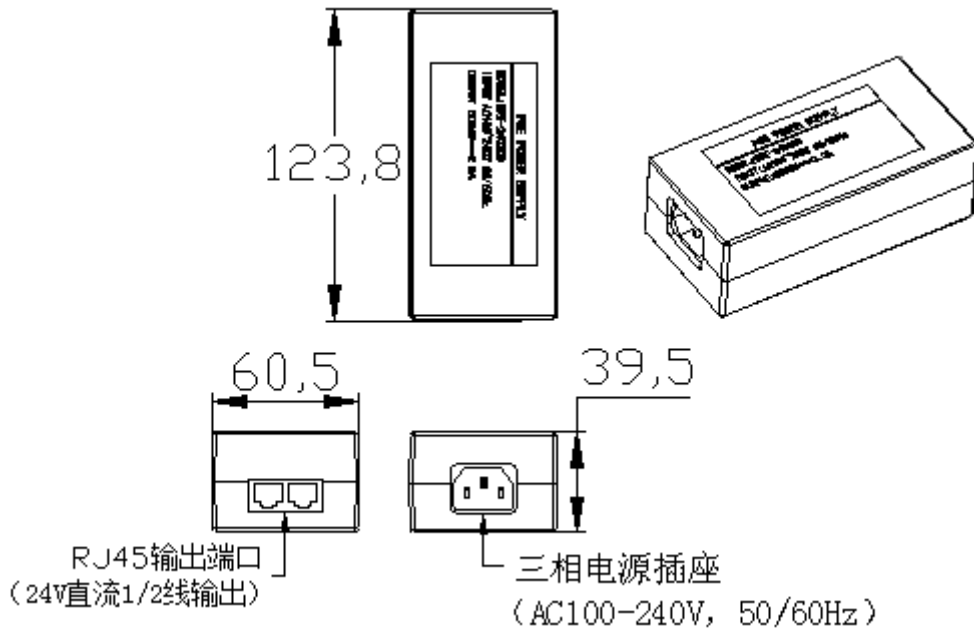

The overall dimension of power adapter is shown as follows:

④Mechanical parameters of communication converter:

Overall dimension: <math>< 90 \times 28 \times 22\text{mm}</math> (L\*W\*H)

Net weight of communication converter: about 20.5g

The overall dimension of communication converter is shown as follows:

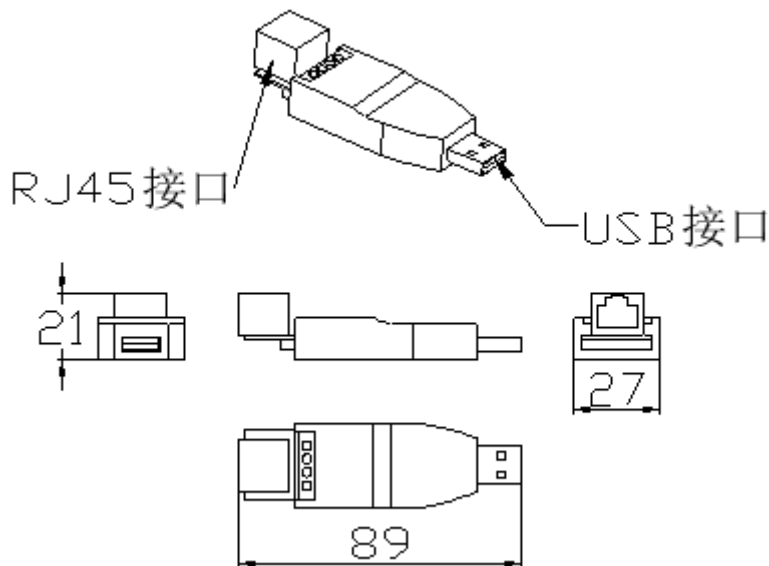

⑥Mechanical parameters of system integrated power supply:

Overall dimension: <math>380 \times 160 \times 50\text{mm}</math> (L\*W\*H)

Net weight of terminal power supply: about 2500g

The overall dimension of terminal power supply is shown as follows:

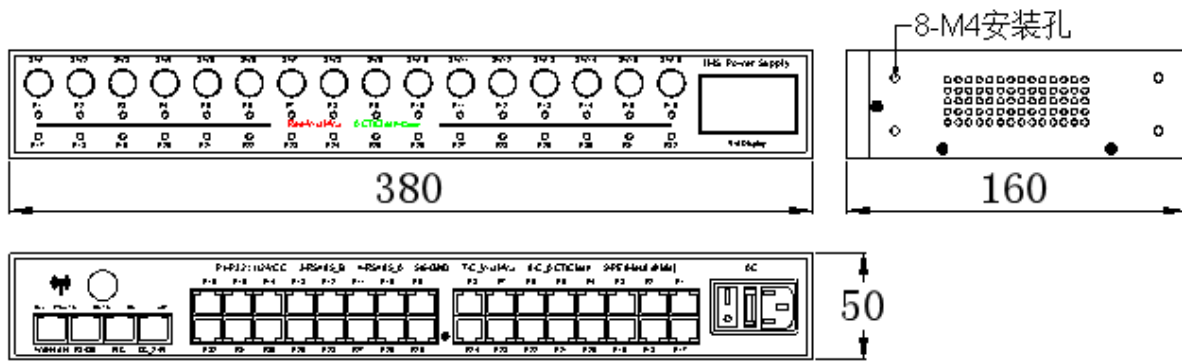

## Operation and precautions

### VI. Operation and precautions

#### 1. Instructions for use:

During use, the plane of the sensor electrostatic detection window should be parallel to the surface of the object under test. The detection distance and detection gear should be selected according to the static electricity quantity and the operating environment of the charged object (i.e. above mentioned standard detection distance: 5mm, 10mm, 25mm, 50mm, 100mm, 150mm, 200mm, 250mm, 300mm, 350mm, 400mm, 450mm, 500mm, 550mm, 600mm, 700mm); at this point, the detection data displayed by the terminal is the most accurate.

2. On-line mode: (Monitoring terminal, integrated power supply and communication software need to be purchased additionally)

For the power output network port, monitoring terminal network port and electrostatic sensor network port of 24V power adapter, the network ports of the three devices are both the power port and the communication port, and the network ports of the three devices can be commonly used.

#### 1) Connection with monitoring terminal:

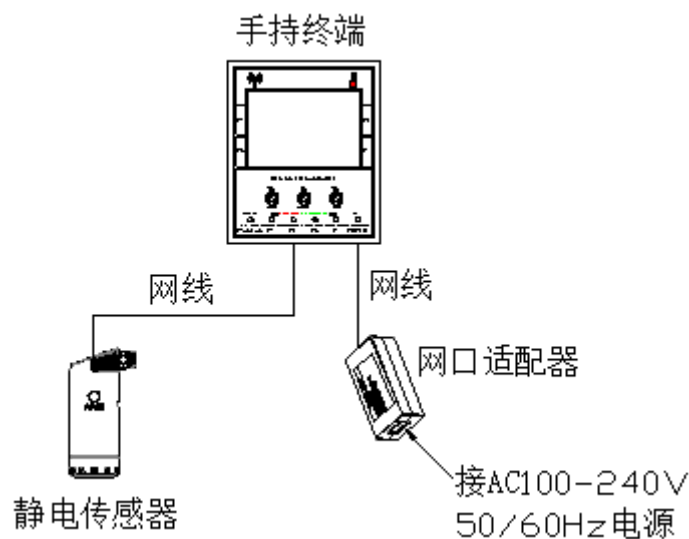

#### 2) Connection with PC:

