



Humidity Cabinets

Designed to reproduce test conditions of high humidity.

www.cw-spec.com

C&W humidity cabinets are designed to reproduce test conditions of high humidity at constant or cycling temperatures.

The test chamber environment is created by water being heated to precise temperatures to generate the production of water vapour. The water vapour saturates the air in the test area which is constantly being circulated by the internal fan to ensure even distribution. The test panels or components are enveloped in the moisture enriched air, allowing the water to be absorbed by the coating and oxidising with the base metal resulting in either blistering of the coating or the formation of red rust or oxidation on a non-ferrous metal. This test is used to reproduce the exposure to naturally occurring condensation or by cycling the temperature, in the cabinet dew formation can be produced. Pioneering designs have made C&W the UK leader in the manufacture of accelerated corrosion and environmental test cabinets.



Air movement either fan assisted or by convection.



"Soft Touch" waterproof membrane keypad control panel.

Operating Modes

C&W humidity cabinets provide a wide range of environmental test conditions:

- ✓ Any constant temperature between 30°C and 70°C. +/- 1°C accuracy.
- ✓ Cyclic temperatures, step-up / step-down over time.
- ✓ Constant high humidity – 95% to 100% saturated.

Precise Control

C&W humidity cabinets are designed for ease of operation. Their comprehensive package of control and display features ensures that all cycles, events and functions can be closely monitored.

- ✓ Microprocessor controller with seven-programme memory.
- ✓ Full digital display of test conditions.
- ✓ Low water sensor protection.
- ✓ Air circulation by internal fan ensures uniform test conditions.
- ✓ Time cycle facility for precise test duration control.
- ✓ NTC temperature sensor for precise control.
- ✓ Over temperature safety cut out system.

Standards

C&W cabinets conform to all leading corporate, national and international standards including:

British/ISO/EN Standards:

BS 3900 F2, BS 3900 F9, BS 3900 F15, ISO 6270, ISO 11503, EN 1096

German Standards:

DIN 50017

American Standards:

ASTM D4585, ASTM D2247, INS 30.16.08,

Corporate Standards:

Ford, GM, Honda, Nissan, Toyota, Volvo, Jaguar, Renault, VW, VG.95210, VG, 95332.



Warranty

Subject to agreed maintenance procedures a two year warranty is available. The standard warranty is one year.



Fully automatic liquid level control of humidifier reservoir.



Low maintenance - high quality.

Design Benefits

C&W humidity cabinets - clean functional design with high specification components

- ✓ Ergonomically designed control panel.
- ✓ Fire retardant GRP plastic structure with high chemical, water and temperature tolerance.
- ✓ Standard panel racks included, options available.
- ✓ Wet seal apex roof, insulated or transparent.
- ✓ Corrosion resistant throughout.

Humidity Function

Humidity cabinets are dedicated cabinets only allowing humidity testing. But you can also obtain a standard corrosion test with humidity function added. This option is available for the following models:

Humidity and Humidity Mebon prohesion

Volume	SF/AB	SF/AB/MP
100	CW1701	CW1801
200	CW1702	CW1802
450	CW1704	CW1804
750	CW1707	CW1807
1000	CW1710	CW1810
2000	CW1720	-



Technical Specifications

Models	CW1301 100 litre	CW1302 200 litre	CW1304 450 litre	CW1307 750 litre	CW1310 1000 litre	CW1320 2000 litre
External Dimensions	L	1000 mm	1030 mm	1370 mm	1740 mm	2750 mm
	W	600 mm	700 mm	930 mm	1230 mm	1220 mm
	H	645 mm	1035 mm	1115 mm	1365 mm	1630 mm
Internal Dimensions	I	600 mm	610 mm	825 mm	1120 mm	2000 mm
	W	450 mm	510 mm	635 mm	870 mm	1000 mm
	H ¹	375 mm	455 mm	620 mm	780 mm	850 mm
	H ²	565 mm	660 mm	875 mm	1070 mm	1175 mm
Panel Capacity	72	80	132	210	344	516
Power Supply Amp	13	13	12	13	20	32
Style	TableTop	Floor Mounted				

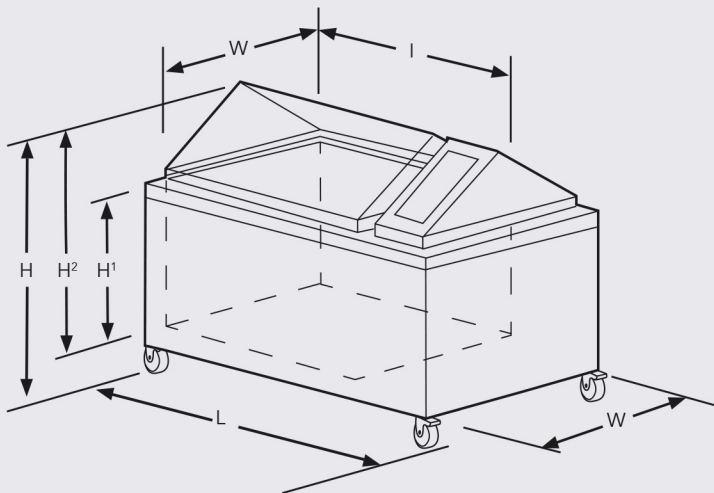

Power Supply	230 V 50/60Hz single phase, other voltages on request
Water Type	De-ionised or mains water below 50 mg/litre TDS
Water Pressure	2 to 4 bar (30 to 60 psi)
Drain	36 mm outside diameter plastic pipe to liquid waste

Optional Extras

- ✦ Continuous paper temperature recorder.
- ✦ Entry ports for sensors, air or power connections.
- ✦ Sample racks, sample rods and spiked racks designed to customer requirements with slots cut to any width, vertical, 6 degrees or 15 degrees.
- ✦ Air purge facility for cabinet ventilation as BS 3900 F15.
- ✦ Slotted apex roof for ISO 6270 - BS 3900 F9 testing.
- ✦ Water temperature controller with submerged sensor to ISO 6270.

All cabinets are CE marked and have calibration traceable to international standards. Certificates of Conformity are supplied on request. Due to continuous development we reserve the right to introduce improvements and /or modify specifications without prior notice.