

GEAR ROOT DIAMETER MICROMETERS

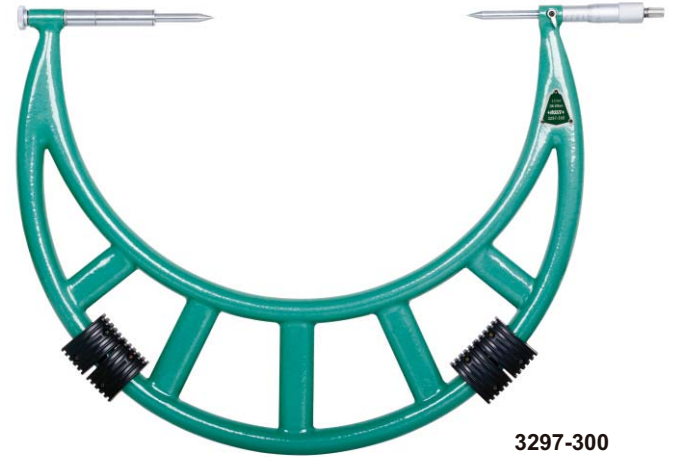

3297-100



3297-300

Unit: mm

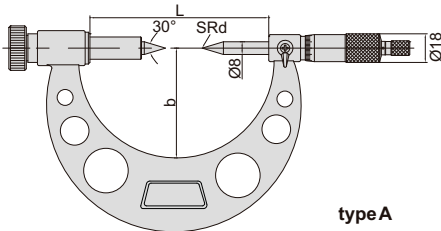

type A

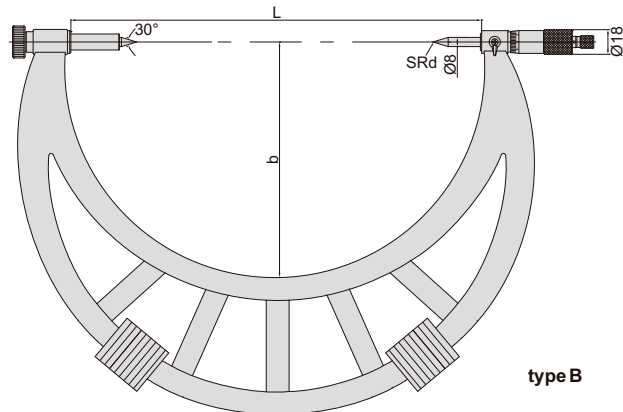

type B

- Measure diameter of gear root circle
- Graduation 0.01mm
- Ratchet stop
- Meet DIN863-3
- Carbide measuring faces
- Supplied with setting standards

							(mm)
Code	Range	Type	Accuracy	L	b	SRd	
3297-100	5-100mm	A	5µm	137	72	0.4	
3297-200	100-200mm	A	7µm	237	129	0.5	
3297-300	200-300mm	B	9µm	414	225	0.7	
3297-400	300-400mm	B	11µm	514	275	0.7	
3297-500	400-500mm	B	13µm	614	325	0.7	
3297-600	500-600mm	B	15µm	714	375	0.7	
3297-700	600-700mm	B	16µm	814	425	0.7	
3297-800	700-800mm	B	18µm	914	475	0.7	
3297-900	800-900mm	B	20µm	1014	525	0.7	