

User's and
Service Guide

Keysight 85039B LO/IF Distribution Unit

Use this manual with the Keysight Antenna
Selection Guide, part number 5968-6759E.

Notices

© Keysight Technologies,
Inc. 2008-2016

No part of this manual may be reproduced in any form or by any means (including electronic storage and retrieval or translation into a foreign language) without prior agreement and written consent from Keysight Technologies, Inc. as governed by United States and international copyright laws.

Trademark Acknowledgments

Manual Part Number

85309-90082

Edition

Edition 2, August 2016

Printed in USA/Malaysia

Published by:
Keysight Technologies
1400 Fountaingrove Parkway
Santa Rosa, CA 95403

Warranty

THE MATERIAL CONTAINED IN THIS DOCUMENT IS PROVIDED "AS IS," AND IS SUBJECT TO BEING CHANGED, WITHOUT NOTICE, IN FUTURE EDITIONS. FURTHER, TO THE MAXIMUM EXTENT PERMITTED BY APPLICABLE LAW, KEYSIGHT DISCLAIMS ALL WARRANTIES, EITHER EXPRESS OR IMPLIED WITH REGARD TO THIS MANUAL AND ANY INFORMATION CONTAINED HEREIN, INCLUDING BUT NOT LIMITED TO THE IMPLIED WARRANTIES OF MERCHANTABILITY AND FITNESS FOR A PARTICULAR PURPOSE. KEYSIGHT SHALL NOT BE LIABLE FOR ERRORS OR FOR INCIDENTAL OR CONSEQUENTIAL DAMAGES IN CONNECTION WITH THE FURNISHING, USE, OR PERFORMANCE OF THIS DOCUMENT OR ANY INFORMATION CONTAINED HEREIN. SHOULD KEYSIGHT AND THE USER HAVE A SEPARATE WRITTEN AGREEMENT WITH WARRANTY TERMS

COVERING THE MATERIAL IN THIS DOCUMENT THAT CONFLICT WITH THESE TERMS, THE WARRANTY TERMS IN THE SEPARATE AGREEMENT WILL CONTROL.

Technology Licenses

The hardware and/or software described in this document are furnished under a license and may be used or copied only in accordance with the terms of such license.

U.S. Government Rights

The Software is "commercial computer software," as defined by Federal Acquisition Regulation ("FAR") 2.101. Pursuant to FAR 12.212 and 27.405-3 and Department of Defense FAR Supplement ("DFARS") 227.7202, the U.S. government acquires commercial computer software under the same terms by which the software is customarily provided to the public.

Accordingly, Keysight provides the Software to U.S. government customers under its standard commercial license, which is embodied in its End User License Agreement (EULA), a copy of which can be found at

<http://www.keysight.com/find/sweula>

The license set forth in the EULA represents the exclusive authority by which the U.S. government may use, modify, distribute, or disclose the Software. The EULA and the license set forth therein, does not require or permit, among other things, that Keysight: (1) Furnish technical information related to commercial computer software or commercial computer software documentation that is not customarily provided to the public; or (2) Relinquish to, or otherwise provide, the government rights in excess of these rights customarily provided to the public to use, modify, reproduce, release, perform, display, or disclose commercial computer software or commercial computer software

documentation. No additional government requirements beyond those set forth in the EULA shall apply, except to the extent that those terms, rights, or licenses are explicitly required from all providers of commercial computer software pursuant to the FAR and the DFARS and are set forth specifically in writing elsewhere in the EULA. Keysight shall be under no obligation to update, revise or otherwise modify the Software. With respect to any technical data as defined by FAR 2.101, pursuant to FAR 12.211 and 27.404.2 and DFARS 227.7102, the U.S. government acquires no greater than Limited Rights as defined in FAR 27.401 or DFAR 227.7103-5 (c), as applicable in any technical data.

Safety Notices

CAUTION

A **CAUTION** notice denotes a hazard. It calls attention to an operating procedure, practice, or the like that, if not correctly performed or adhered to, could result in damage to the product or loss of important data. Do not proceed beyond a CAUTION notice until the indicated conditions are fully understood and met.

WARNING

A **WARNING** notice denotes a hazard. It calls attention to an operating procedure, practice, or the like that, if not correctly performed or adhered to, could result in personal injury or death. Do not proceed beyond a WARNING notice until the indicated conditions are fully understood and met.

Printing Copies of Documentation from the Web

To print copies of documentation from the Web, download the PDF file from the Keysight web site:

- Go to <http://www.keysight.com>.
- Enter the product model number (Ex: 85309B) in the Search function.
- Click Search.
- Click the Manuals hyperlink.
- Click the hyperlink title for the document you want to print - this downloads the PDF
- Print the document after the PDF has fully downloaded.

Definitions

- Specifications describe the performance of parameters covered by the product warranty (temperature –0 to 50 °C, unless otherwise noted.)
- Typical describes additional product performance information that is not covered by the product warranty. It is performance beyond specification that 80% of the units exhibit with a 95% confidence level over the temperature range 20 to 30 °C. Typical performance does not include measurement uncertainty.
- Nominal values indicate expected performance or describe product performance that is useful in the application of the product, but is not covered by the product warranty.
- Characteristic Performance describes performance parameter that the product is expected to meet before it leaves the factory, but is not verified in the field and is not covered by the product warranty. A characteristic includes the same guard bands as a specification.

85309B Overview

The 85309B LO/IF Distribution Unit is a broadband, distributed frequency converter that utilizes fundamental mixing to provide the performance for antenna test systems. The 85309B, together with mixers in the antenna test configuration (not supplied), down convert a microwave signal to an IF signal. This IF signal is input directly to the PNA digitizer (via either front panel jumpers or a rear panel connector), bypassing the PNA's RF conversion stage, for increased measurement sensitivity.

The 85309B LO/IF Distribution Unit contains LO signal amplifiers, which amplify LO drive power through RF cables to the mixers in the antenna test configuration. The high output power allows the mixers to be located more

than seven meters from the 85309B. There are also IF amplifiers located in the 85309B, which serve as a preamplifier for the receiver, reducing the overall system noise figure significantly.

The 85309B LO/IF Distribution Unit can be installed in a variety of configurations for antenna testing. To learn about the various system configurations, refer to the “Configuration Examples” section in Chapter 1 of this document, and the online document Keysight Antenna Test Selection Guide, part number 5968-6759E. See “Printing Copies of Documentation from the Web” on the previous page.

85309B Options

85309B Standard

Provides one test channel and one reference channel.

85309B Option 001 - One Additional Test Channel

Adds one additional test channel. Provides a total of two test channels and one reference channel.

85309B Option 002 - Two Additional Test Channels

Adds two additional test channels. Provides a total of three test channels and one reference channel.

85309B Option 400 - Low and High Frequency Bands, One Test Channel

0.1 – 1 GHz low frequency band; 0.3 – 18 GHz high frequency band. Provides a total of one test channel and one reference channel.

85309B Option 401 - Low and High Frequency Bands, Two Test Channels

0.1 – 1 GHz low frequency band; 0.3 – 18 GHz high frequency band. Adds one additional test channel. Provides a total of two test channels and one reference channel.

85309B Option 402 - Low and High Frequency Bands, Three Test Channels

0.1 – 1 GHz low frequency band; 0.3 – 18 GHz high frequency band. Adds two additional test channels. Provides a total of three test channels and one reference channel.

Option 1CM - Rack Mount Kit Without Handles

Rack mount kit without handles. To obtain this item after receiving the 85309B, order part number 5063-9214.

Option 1CP - Rack Mount Kit With Handles

Rack mount kit with handles. To obtain this item after receiving the 85309B, order part number 5063-9221.

Table of Contents

1. Getting Started

STEP 1. Check the Shipment	2-1
STEP 2. Meet Electrical and Environmental Requirements	2-1
Step 3. Connect the 85309B with Other System Components	2-2
Compatible Network Analyzers	2-2
Configuration Examples	2-3
Step 4. (Option 40x Only): Set the 85309B Band Selection	2-6
Step 5: Power On the 85309B	2-6
Step 6. Adjust the LO Power	2-7
Procedure	2-7
STEP 7. (Optional) Run the 85309B Operator's Check	2-8
Getting Help with Your 85309B	2-9
Keysight Antenna Test Selection Guide	2-9
Contacting Keysight	2-9
Shipping Your Instrument to Keysight for Service or Repair	2-9

2. Operating Information

Electrostatic Discharge Protection	3-1
85309B Front Panel Features	3-3
DETECTOR VOLTAGE Display	3-3
LO POWER ADJUST	3-3
LO POWER OUT OF RANGE	3-4
BAND SELECTION (Option 40x Only)	3-4
85309B Rear Panel Features	3-6
Ref Mixer Connector Group	3-6
Test Mixers Connector Group	3-7
LO Source Connector Group	3-7
Receiver Connector Group	3-8
Available Fuses	3-9
85309B Block Diagrams	3-10
Instrument Block Diagrams Sheet 1	3-11
Instrument Block Diagrams Sheet 2	3-11
Cable Length Limits	3-13
Performing the Operator's Check	3-16
Function	3-16
Description	3-16
Equipment Required	3-17
LO Power Output Test	3-17

Contents

Reference IF and Test IF	3-22
IF the Operator's Check Fails	3-25
3. General Information	
General Specifications	1-1
85309B Characteristic Performance	1-3
General Safety Considerations	1-5
Introduction	1-5
Cleaning the Instrument	1-5
Connector Care and Cleaning	1-5
Declaration of Conformity	1-5
Statement of Compliance	1-6
General Safety Considerations	1-6
Regulatory Information	1-9
Instrument Markings	1-9
4. Service	
Replaceable Parts	2-1
Introduction	2-1
Ordering Information	2-1
Replaceable Parts Listings	2-2

1 Getting Started

STEP 1. Check the Shipment

1. Unpack the contents of the shipping container. Keep the packaging material in case the analyzer needs to be returned to the factory.
2. Carefully inspect the 85309B to make sure that it was not damaged during shipment. If damaged, refer to **“Contacting Keysight” on page 9.**
3. Use the Contents List in the shipping container to verify the completeness of your shipment. If not complete, refer to **“Contacting Keysight” on page 9.**

STEP 2. Meet Electrical and Environmental Requirements

CAUTION

This instrument has autoranging line voltage input. Be sure the supply voltage is within the specified range.

-
1. Ensure the available AC power source meets the requirements found in **“General Specifications” on page 1.**
 2. Ensure the operating environment meets the requirements found in **“General Specifications” on page 1.**
 3. Verify that the AC power cable is not damaged, and that the power-source outlet provides a protective earth contact.

CAUTION

Always use the three-prong AC power cord supplied with this product. Failure to ensure adequate earth grounding by not using this cord may cause personal injury or product damage.

-
4. Plug the unit into an appropriate AC power source.

Step 3. Connect the 85309B with Other System Components

Your antenna test system configuration includes the 85309B and a PNA network analyzer. The need for other components is determined by the type of measurements required.

To learn about the various system configurations, refer to the *Keysight Antenna Test Selection Guide*, part number 5968-6759E. See “Printing Copies of Documentation from the Web” in the first section of this manual.

CAUTION

The 85309B should be turned off when connecting it with other system components.

Compatible Network Analyzers

The following network analyzers are compatible with the 85309B.

Family	Receiver	Firmware	Required Options
PNA	E836xC	All revisions	H11
	N522xA	All revisions	020
PNA-X	N524xA	All revisions	020
	N5264A	All revisions	None

Configuration Examples

Figure 1-1 Simplified Configuration Block Diagram

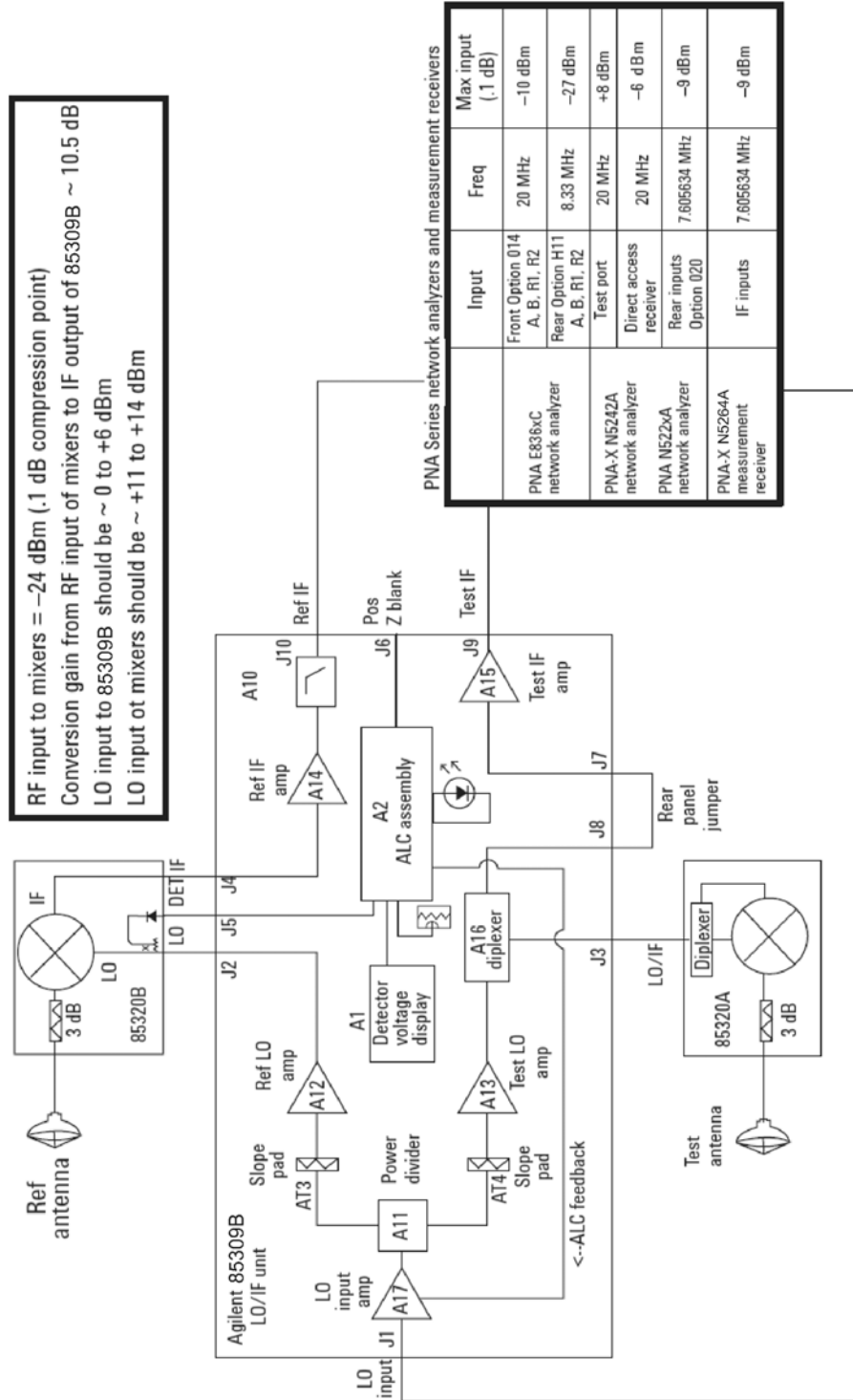
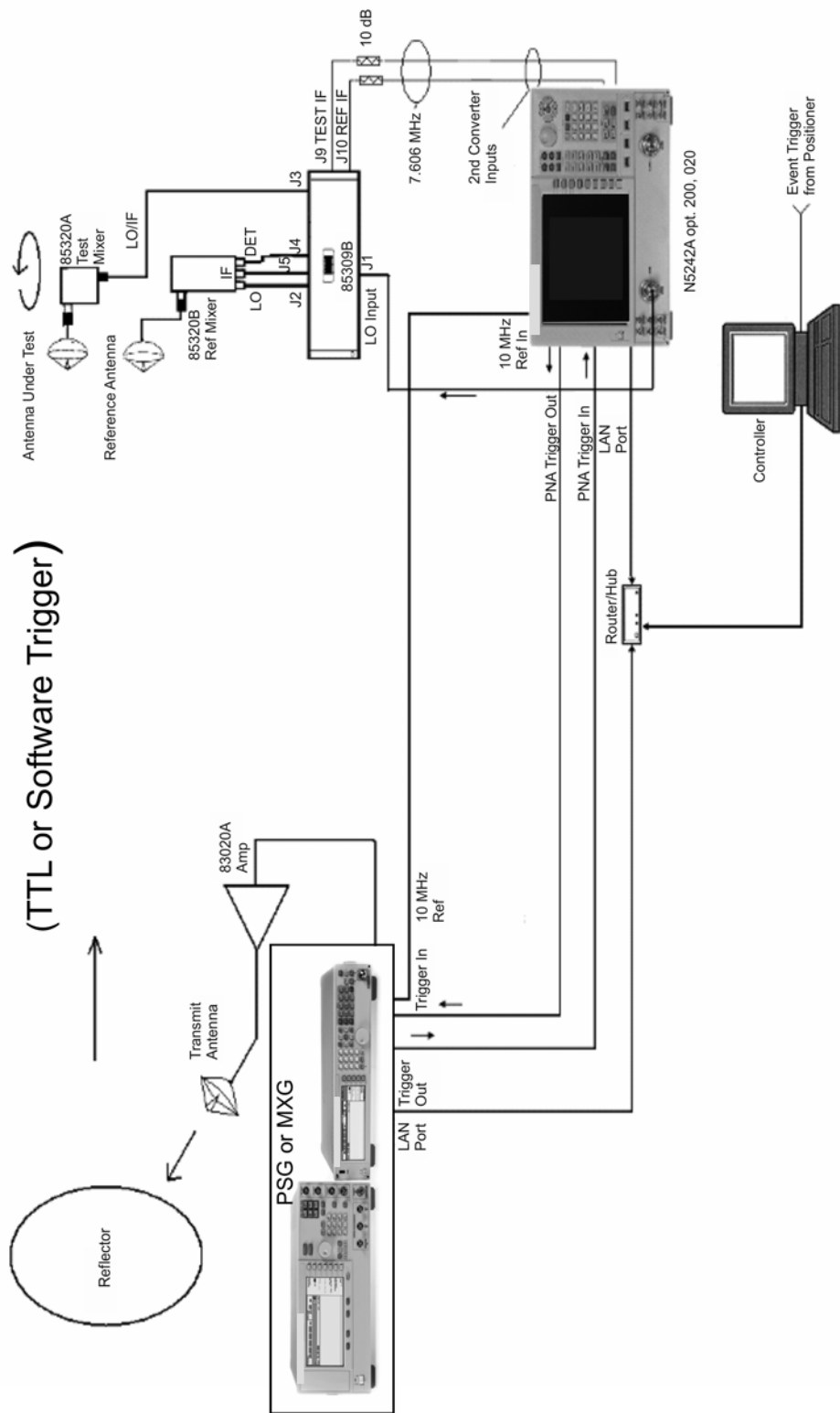

Figure 1-3 Typical PNA-X Compact Range Configuration



85309_082_23

Step 4. (Option 40x Only): Set the 85309B Band Selection

The Band Selection knob on the front panel of the 85309B Option 400/401/402 models allows the user to switch between the low band, high band, and external selections. For more information, refer to **“85309B Front Panel Features” on page 3**.

Step 5: Power On the 85309B

Power on the 85309B by pressing the front panel On/Off switch.

If the 85309B will not power on, make sure the instrument is plugged into an operating AC power outlet, and check the fuse.

Step 6. Adjust the LO Power

The procedure below is applicable to all 85309B models, and assumes the user has basic knowledge on the antenna test system. To learn about the various antenna test systems, refer to the *Keysight Antenna Test Selection Guide*, part number 5968-6759E. See “Printing Copies of Documentation from the Web” in the first section of this manual.

The front panel of the 85309B has a DETECTOR VOLTAGE window, an LO POWER ADJUST mechanism, and an LO POWER OUT OF RANGE LED. Refer to **“85309B Front Panel Features” on page 3**. The value shown in the DETECTOR VOLTAGE window is the voltage coming from a power detector in the reference mixer. The voltage is directly proportional to the amount of LO power arriving at the mixer. A label on the reference mixer shows the precise voltage which corresponds to the power at the mixer's LO input. In the procedure below, you adjust the LO POWER ADJUST so the DETECTOR VOLTAGE display matches the voltage on the mixer label.

Once set, the ALC loop will maintain the desired LO power level regardless of LO frequency. Repeat the procedure below only if you change one of the mixer modules or the LO source.

Find the detector voltage value written on the reference mixer. Record the value in **Table 1-1** below.

Table 1-1 Value Indicated on the Reference Mixer

Parameter	Value
	mV (typically -40 to -80):

Procedure

1. Set the LO source power to 6 dBm.
2. Observe the voltage displayed in the 85309B's front panel DETECTOR VOLTAGE window.
3. Adjust the 85309B's LO POWER ADJUST mechanism until the voltage displayed in the window is equal to the voltage written in **Table 1-1** (also shown on the reference mixer label). If the LO POWER OUT OF RANGE LED is lit, there is an unlevelled ALC state. To fix the problem, refer to **“LO POWER OUT OF RANGE” on page 4**. Note that due to the long LO cable length (the RF cable between the LO source and the 85309B) you must compensate for cable loss by increasing the LO source power.

NOTE

The voltage displayed in the DETECTOR VOLTAGE window varies with frequency. This is normal. The LO POWER OUT OF RANGE LED is lit only if the system's automatic leveling loop cannot level the voltage sufficiently. This can happen if the LO source is disconnected, or if more power is needed than the 85309B unit can supply for a given frequency range.

STEP 7. (Optional) Run the 85309B Operator's Check

The operator's check should be performed when you first receive your 85309B, and any time you wish to have confidence that it is working properly. The operator's check does not verify performance to specifications, but should give you a high degree of confidence that the 85309B is performing properly.

For instructions, refer to **“Performing the Operator's Check” on page 16.**

Getting Help with Your 85309B

Keysight Antenna Test Selection Guide

Use the Keysight Antenna Test Selection Guide (part number 5968-6759E) to:

- Learn about interface requirements between system components.
- Understand issues related to selecting the equipment required to make antenna measurements.

For information on how to view and print this document online, see “Printing Copies of Documentation from the Web” in the first section of this manual.

Contacting Keysight

Assistance with test and measurements needs and information or finding a local Keysight office are available on the Web at:

<http://www.keysight.com/find/assist>

If you do not have access to the Internet, please contact your Keysight field engineer.

NOTE

In any correspondence or telephone conversation, refer to the Keysight product by its model number and full serial number. With this information, the Keysight representative can determine whether your product is still within its warranty period.

Shipping Your Instrument to Keysight for Service or Repair

If you wish to send your instrument to Keysight Technologies for service or repair:

- Include a complete description of the service requested or of the failure and a description of any failed test and any error message.
- Ship the instrument using the original or comparable anti-static packaging materials.
- Contact Keysight for instructions on where to ship your instrument.

Getting Started
Getting Help with Your 85309B

2 Operating Information

Electrostatic Discharge Protection

Protection against electrostatic discharge (ESD) is essential while removing assemblies from or connecting cables to the 85309B. Static electricity can build up on your body and can easily damage sensitive internal circuit elements when discharged. Static discharges too small to be felt can cause permanent damage. To prevent damage to the instrument:

- **always** have a grounded, conductive table mat in front of your test equipment.
- **always** wear a grounded wrist strap, connected to a grounded conductive table mat, having a 1 M Ω resistor in series with it, when handling components and assemblies or when making connections.
- **always** wear a heel strap when working in an area with a conductive floor. If you are uncertain about the conductivity of your floor, wear a heel strap.
- **always** ground yourself before you clean, inspect, or make a connection to a static-sensitive device or test port. You can, for example, grasp the grounded outer shell of the test port or cable connector briefly.
- **always** ground the center conductor of a test cable before making a connection to any static-sensitive device. This can be done as follows:
 1. Connect a short (from your calibration kit) to one end of the cable to short the center conductor to the outer conductor.
 2. While wearing a grounded wrist strap, grasp the outer shell of the cable connector.
 3. Connect the other end of the cable to the test port and remove the short from the cable.

Figure 2-1 shows a typical ESD protection setup using a grounded mat and wrist strap. Refer to Chapter 6 for part numbers.

Figure 2-1 ESD Protection Setup

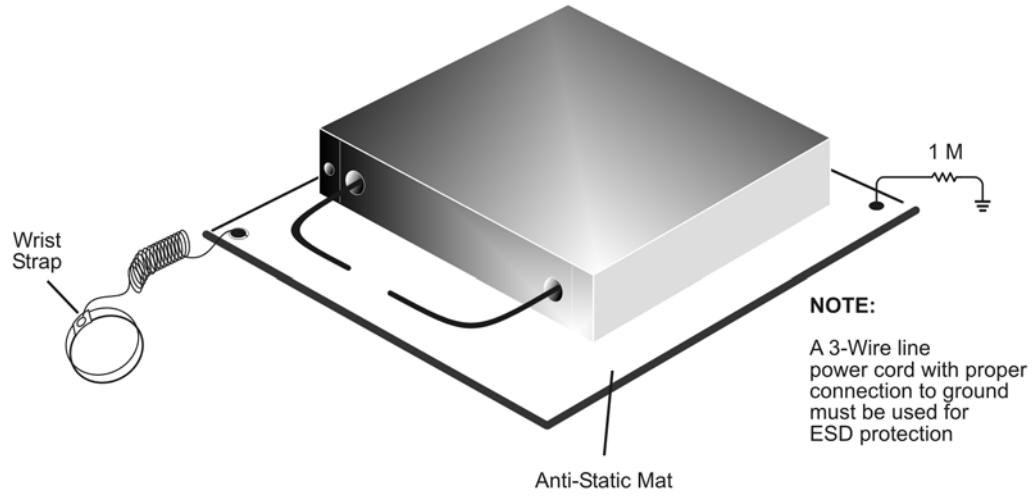

85310_002_101

85309B Front Panel Features

Figure 2-2 85309B Standard/Option 001/002 Front Panel

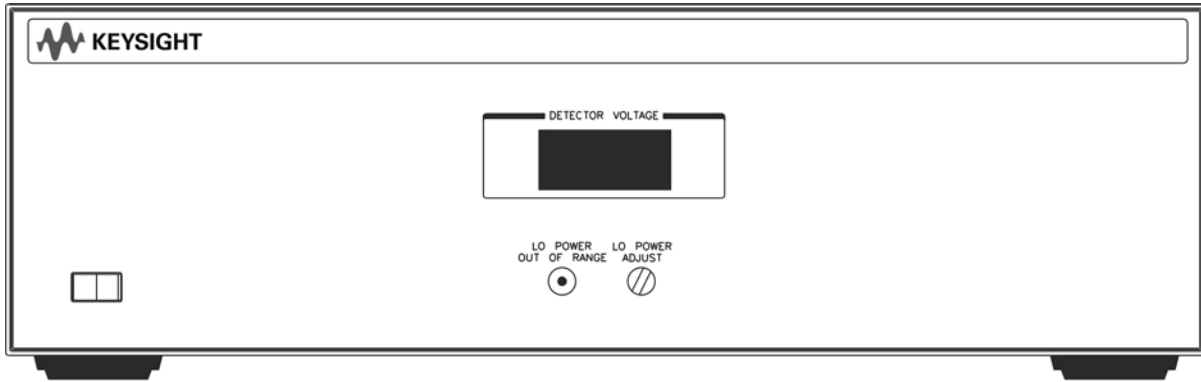

85310_002_301

Figure 2-3 85309B Option 400/401/402 Front Panel

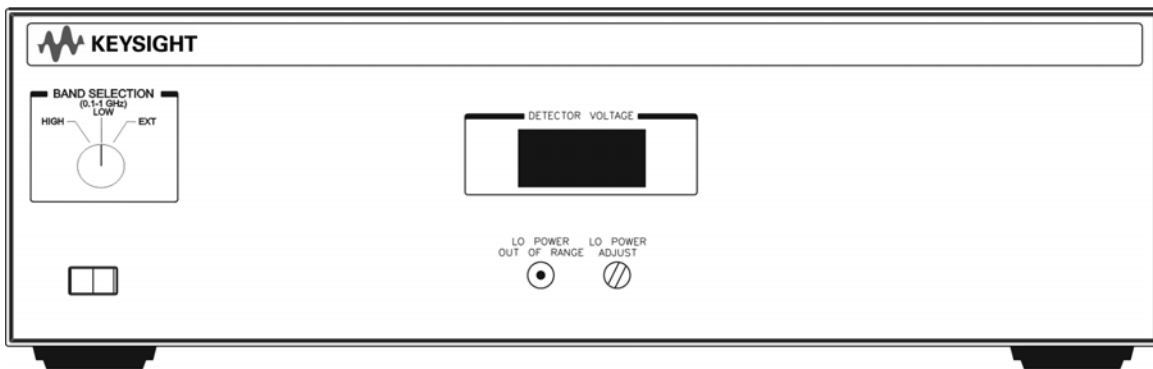

85309_082_01

DETECTOR VOLTAGE Display

The reference mixer has a detector that measures the amount of LO power coming into its LO input. This voltage is sent to the 85309B where it is displayed in the DETECTOR VOLTAGE display. The voltage is directly proportional to the amount of LO power.

This display allows you to monitor the amount of LO power going to the reference mixer. It is assumed that the cable lengths to the reference and test mixers are the same. This ensures that the LO power going to the test mixer is the same as that going to the reference mixer.

LO POWER ADJUST

This adjustment controls the amount of LO power going to the mixers.

The 85309B and LO source must provide enough power to match the needs of your specific mixers and to compensate for loss through the LO cable (the cable that goes from the LO source to the 85309B). **“Step 6. Adjust the LO Power” on page 7** explains how to select the proper amount of power.

LO POWER OUT OF RANGE

When lit, this LED indicates that the LO source is not supplying the amount of LO power requested by the LO POWER ADJUST control.

The LO POWER OUT OF RANGE circuit compares the LO POWER ADJUST setting with the voltage coming back from the reference detector. The amount of expected detector voltage varies depending on the LO POWER ADJUST setting. Normally the detector voltage is within the expected range, and the LED is not lit. However, if anything interrupts the ALC loop, or a relatively low detector voltage is measured, the LED is lit. (The circuit activates the light if the detector voltage is not within 25% of the expected voltage.) If the LED is lit, the cause may be one or more of the following:

- The LO source is not set to output a sufficient amount of power. To remedy this, increase power output (if possible). Make sure your LO source can generate sufficient power at the maximum LO frequency.
- The LO POWER ADJUST is not set properly on the 85309B. Refer to **“Step 6. Adjust the LO Power” on page 7** for instructions.
- The LO source's RF OUTPUT is not connected to the 85309B, or the LO source is turned off. This can also happen if the LO source is on, but its RF output is turned off.
- The LO source is not able to supply the requested amount of power in the measurement frequency range. Make sure your LO source is specified to produce enough power in the desired frequency range. If the LO cannot produce enough power at high frequencies, the LO POWER OUT OF RANGE LED will be lit during the high-frequency portion of the measurement. During this time LO power will not be correct.
- The reference mixer is not connected to the REFERENCE LO OUTPUT of the 85309B (in other words, the reference mixer is not getting sufficient LO power).
- The reference mixer's Detector Voltage output is not connected to the 85309B.
- There is a failure of the 85309B's ALC circuitry. An ALC failure will usually cause the LED to be lit permanently, even though all equipment is connected properly.

BAND SELECTION (Option 40x Only)

The Band Selection knob on the front panel of the 85309B Option 400/401/402 models allows the user to switch between the low band, high band, and external selections. The Band Selection switch positions are:

Operating Information
85309B Front Panel Features

- LOW 0.1 GHz to 1 GHz operating frequency.
- HIGH 0.3 GHz to 18 GHz operating frequency.
- EXT Enables external control of band selection via rear panel J15 HIGH/LOW BAND SELECT port. TTL high (+5 V) selects HIGH band; TTL low (0 V) selects LOW band.

NOTE

Use Keysight 85320A/B Option H20 external mixer modules to utilize the 0.1 GHz to 3 GHz frequency range of operation.

If the green LED above the Band Selection knob is lit, the HIGH band is selected. If the LED is not lit, the LOW band is selected.

85309B Rear Panel Features

CAUTION

The 85309B contains static sensitive devices. Never touch the center conductor of any connector. When cleaning connectors, wear a grounded wrist strap.

Figure 2-4 shows 85309B Option 402 rear panel features, including two additional test channels and an active J15 “High/Low Band Select” port. The rear panel on your 85309B model may not include all of the ports shown. Note that the connectors are arranged in the following groups:

- Ref Mixer
- Test Mixers
- LO Source
- Receiver
- J7 and J8 are separate connectors that function as jumpers for the IF path or as ports for non-diplexed test mixers of the LO/IF unit.
- (Option 40x only) J15 is a separate connector that allows external control of the HIGH/LOW BAND SELECT feature.

Figure 2-4 85309B Rear Panel Features (Option 402)



85309_082_04

Ref Mixer Connector Group

The three Type-N female connectors in this group, J2 REFERENCE LO OUT, J4 REFERENCE IF IN, and J5 REFERENCE DET IN, are connected to the reference mixer. Besides the RF, LO, and IF ports, the reference mixer has an additional DETECTOR output.

J2 REFERENCE LO OUT. This port sends the local oscillator signal to the reference mixer.

J4 REFERENCE IF IN. This port receives the IF from the reference mixer. The 85309B amplifies this signal and sends it to the receiver using the J10 REFERENCE IF OUT connector.

J5 REFERENCE DET IN. A power detector in the reference mixer measures incoming LO power and outputs a proportional voltage. This voltage enters the 85309B through this connector, and is used to level the LO power. The allowable input voltage range for this connector is 0 to -200 mV.

Test Mixers Connector Group

The three Type-N female connectors in this group, J3 TEST 1 LO/IF (standard), J11 TEST 2 LO/IF (option 001 or 401), and J13 TEST 3 LO/IF (option 002 or 402), are connected to the test mixers. A test mixer only requires one connection. A diplexer allows the LO signal (which goes to the test mixer) and the IF signal (which comes back from the test mixer) to travel over the same physical cable. This allows both signals to go through a single-channel rotary joint.

J3 TEST 1 LO/IF (standard). This port sends the local oscillator signal to the test mixer, and receives the IF signal over the same connection. A diplexer inside the test mixer and the 85309B makes this possible.

The IF signal from the test mixer is amplified and sent to the receiver through J9 TEST 1 IF OUT.

J11 TEST 2 LO/IF (option 001). This port operates the same as the TEST 1 LO/IF port. Option 001 or 401 adds a second test channel.

The IF signal from a second test mixer is amplified and sent to the receiver through J12 TEST 2 IF OUT.

J13 TEST 3 LO/IF (option 002). This port operates the same as the TEST 1 LO/IF and TEST 2 LO/IF ports. Options 002 or 402 adds a third test channel.

The IF signal from a third test mixer is amplified and sent to the receiver through J14 TEST 3 IF OUT.

LO Source Connector Group

The two Type-N female connectors in this group, J1 LO INPUT and J6 POS Z BLANK, are connected to the LO source.

J1 LO INPUT. Receives the local oscillator signal from the LO source. The 85309B distributes this to the test and reference mixers.

J6 POS Z BLANK. The LO source sends out the POS Z BLANK (TTL logic) signal during sweep retrace. POS Z BLANK is monitored by the 85309B through this connector. The 85309B monitors this signal, and lowers the gain in the automatic leveling control circuit during retrace. This keeps the gain of the ALC from peaking during known power drops.

Receiver Connector Group

The four BNC connectors in this group, J9 TEST 1 IF OUT (standard), J10 REFERENCE IF OUT, J12 TEST 2 IF OUT (option 001 or 401), and J14 TEST 3 IF OUT (option 002 or 402), output the test and reference IF signals to the receiver.

J9 TEST 1 IF OUT (standard). This connector sends the test mixer's IF signal to the receiver. Generally, this signal is connected, through the BNC-to-RECEIVER ADAPTER cable, to the receiver b2 input.

J10 REFERENCE IF OUT. This connector sends the reference mixer's IF signal to the receiver. Generally, this signal is connected, through the BNC-to-RECEIVER ADAPTER cable, to a1 on the receiver.

J12 TEST 2 IF OUT (option 001 or 401). This connector sends the test mixer's IF signal to the receiver. Generally, this signal is connected, through the BNC-to-RECEIVER ADAPTER cable, to the receiver b1 input.

J14 TEST 3 IF OUT (option 002 or 402). This connector sends the test mixer's IF signal to the receiver. Generally, this signal is connected, through the BNC-to-RECEIVER ADAPTER cable, to the receiver a2 input.

J7 and J8 (Using Non-Diplexed Mixers). J7 and J8 allow you to use a non-diplexed test mixer (a mixer that has separate connections for the LO and IF signal). This is done by removing the Type-N jumper that normally connects J7 and J8. With the jumper removed, make the following connections to your test mixer:

Table 2-1 Connections for Non-Diplexed Mixers

85309B Connector	Connection
J3 TEST LO/IF	Mixer LO INPUT
J7 TEST IF IN	Mixer IF OUTPUT
J8 DIPLEXER IF OUT	50-ohm Load ^a

a. It is recommended that you place a 50-ohm load on this connector.

If you are using a test mixer that uses a single LO/IF connection and a diplexer, always place the supplied Type-N jumper between J7 and J8.

J15 HIGH/LOW BAND SELECT (option 40x). Allows external control of the HIGH/LOW BAND SELECT feature when the front panel BAND SELECTION knob is in the EXT position. See **“BAND SELECTION (Option 40x Only)”** on [page 4](#). TTL high (+5 V) selects HIGH band; TTL low (0 V) selects LOW band.

Available Fuses

- Fuse (5 A/250V, 2110-0709) U.L. listed and CSA certified

WARNING

For continued protection against fire hazard replace line fuse only with same type and rating: Fuse 5A/250V, Part Number 2110-0709. The use of other fuses or material is prohibited.

Figure 2-5

Line Fuse



85309B Block Diagrams

Block diagrams are located on the following two pages.

85309B Block Diagram

Rev 10

Option 400/401/402

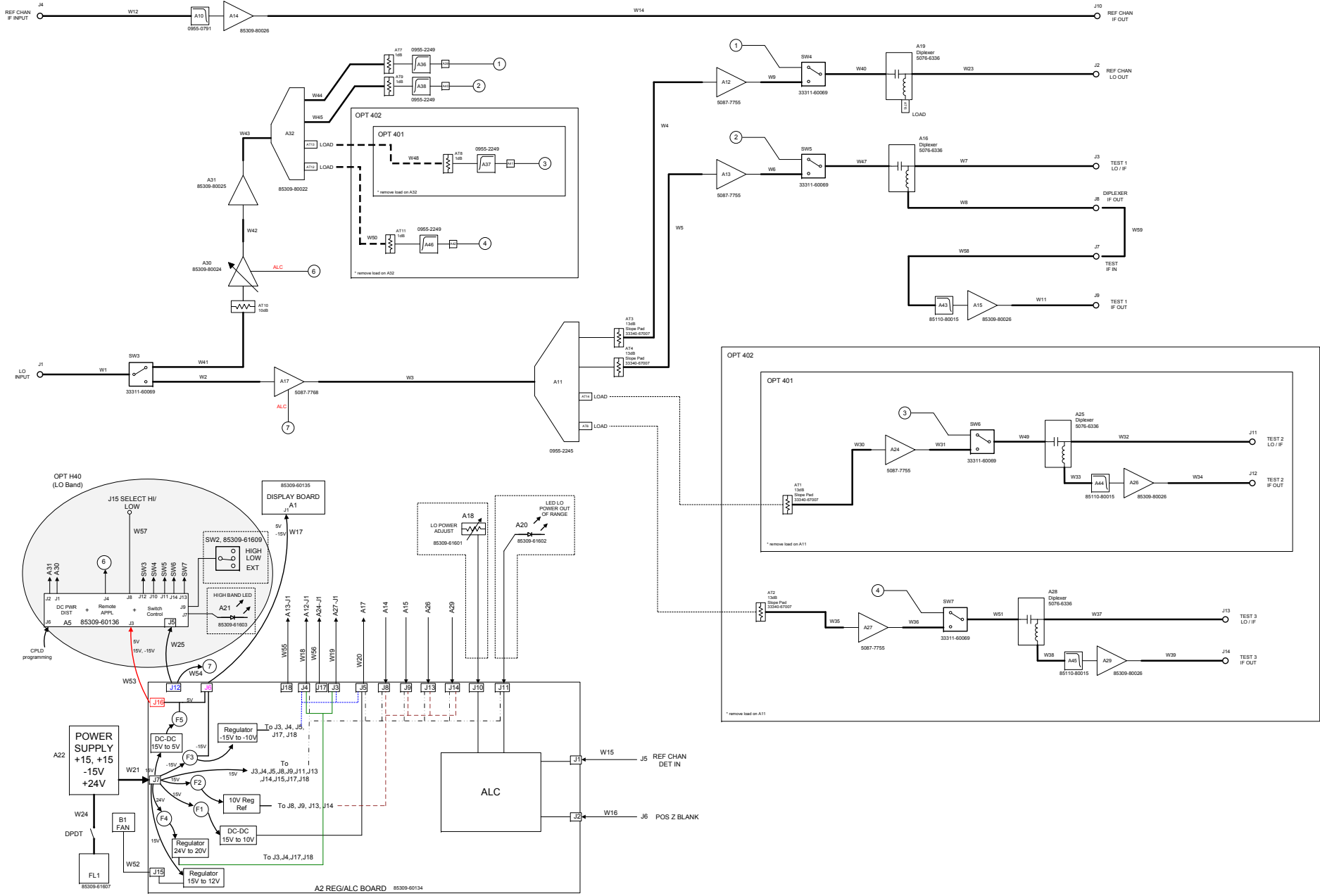

Cable Length Limits

The following figure defines the allowable maximum cable lengths from the LO Source to the 85309B, and the cable connecting the 85309B and the external mixers. The cable lengths are provided when using standard RF cable assemblies and with MicroCoax (UFB311A RF) low-loss cable assemblies.

The standard mixers used in Keysight antenna measurement systems are the 85320A test mixer and the 85320B reference mixer. Both mixers operate from 2 to 18 GHz in fundamental mode, and from 6 to 26.5 GHz in third-harmonic mode. **Figure 2-6 on page 14** and **Figure 2-7 on page 15** show the RF power levels required for proper operation with the 85320A/B mixers and various other mixer products provided by Keysight Technologies.

Figure 2-6 Cable Length Configurations (1 of 2)

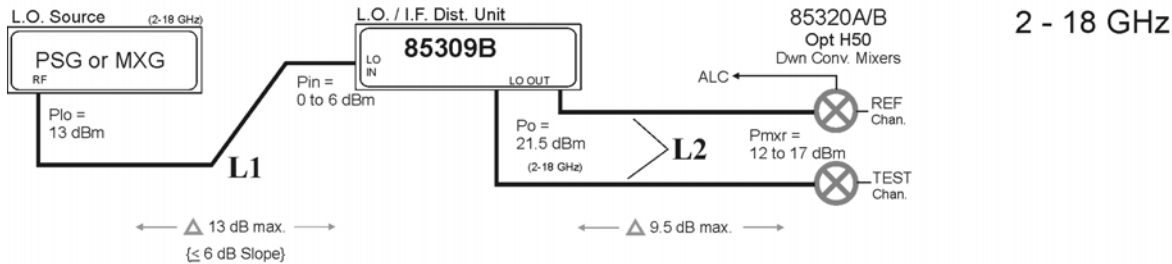
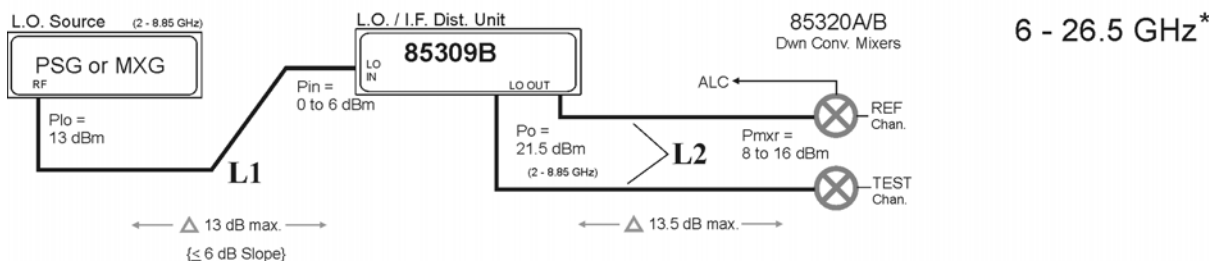
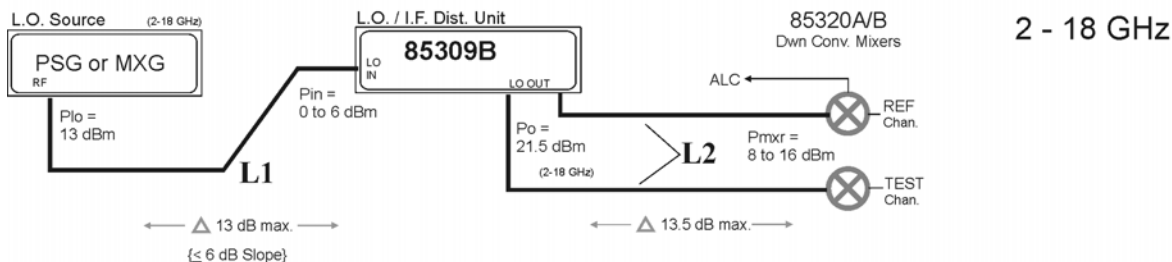
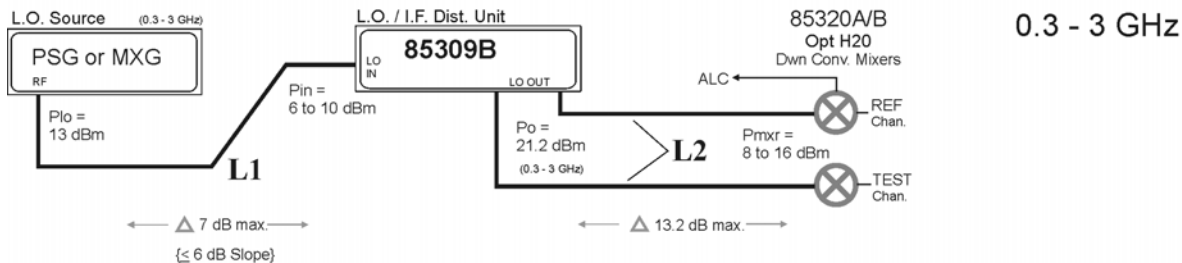
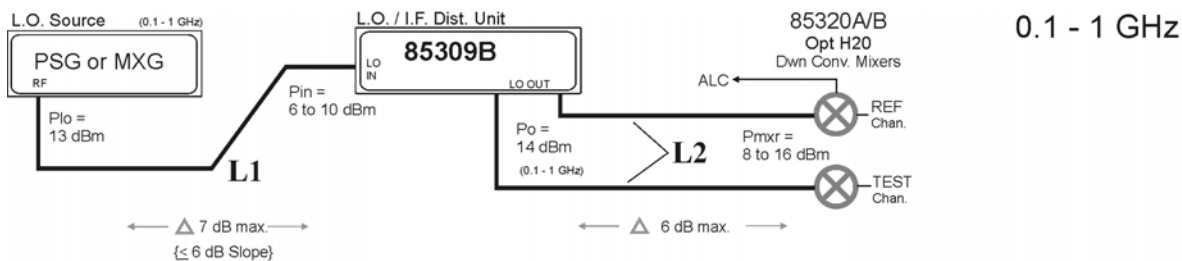

* Mixers are operated in the 3rd harmonic mode.

conf_h42

Operating Information
Cable Length Limits

Figure 2-7 Cable Length configurations (2 of 2)

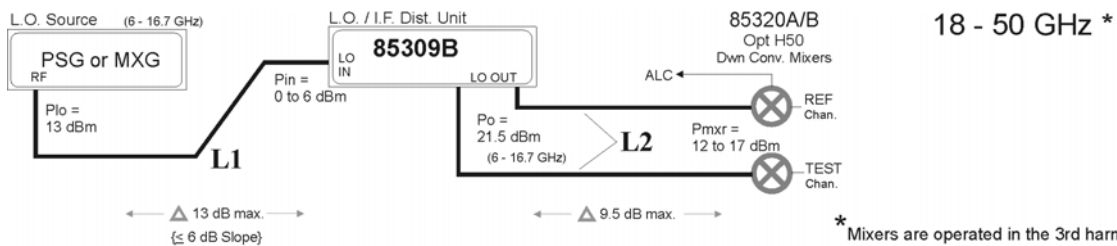

conf_h42-2

Performing the Operator's Check

Function

The Operator's Check verifies that the 85309B functions properly before permanent installation in the antenna test system. It may also be used as a stand-alone check anytime that a problem is suspected with the 85309B.

Description

The Operator's Check drives an LO power signal into the rear panel LO INPUT (J1) port and measures the power output response of the LO channels (reference and test) across the entire frequency range of operation. It also checks the Reference IF and Test IF channels. Passing the Operator's Check indicates that all 85309B internal cables have stable connections and that the amplifiers are working properly.

The Operator's Check consists of the following tests:

- **“LO Power Output Test” on page 17**
- **“Reference IF and Test IF” on page 22**

Equipment Required

Table 2-2 Equipment Required for the Operator's Check

Equipment Type	Recommended Model or Part Number	Alternate Model or Part Number
PNA/ENA ^a	Any PNA with frequency range up to 18 GHz	Any ENA with frequency range up to 18 GHz
30 dB pad attenuator ^b	08493-60017	11708A or equivalent
Power meter	E4418B/19B	N1913A
Power sensor	E4413A	8485A
Cables	85131C	85131E
Adapter, 3.5 mm (m-m)	83059A	85052-60014
Adapter, Type N (m) to SMA (m)	1250-1636	equivalent
Adapter, BNC (f) to SMA (m)	1250-1200	equivalent
Adapter, SMA (f-f)	1250-1158	equivalent

- a. If users don't have a PNA, an ENA may be used. The PNA and ENA can supply the LO signal since the LO sources only need to operate over the frequency range of 0.1 to 18 GHz. The LO source must also be able to supply -35 dBm to 6 dBm power.
- b. An external 30 dB pad attenuator is required if the receiver does not have an internal step attenuator.

LO Power Output Test

NOTE

The PNA input must be attenuated to avoid causing receiver compression or damaging the receiver. An external 30 dB pad attenuator is required if the PNA does not have an internal source step attenuator. The instructions for this test use PNA Port 1 to generate the LO source, and use PNA Port 2 as receiver B.

NOTE

All keystrokes in the following procedure are for the PNA. Using an ENA may require different keystrokes.

1. On the PNA, select Preset.
2. Unless already accomplished by the Preset selection, select Start Frequency and enter 0.1 GHz, then select Stop Frequency and enter 18 GHz.
3. To activate the PNA receiver B, select Response > Meas > More > Receivers.
4. Set the Port 1 source power level to 0 dBm.

5. Zero and calibrate the power sensor.
6. Connect a test cable between PNA Port 1 and the power sensor.
7. To perform the source power calibration, select Cal > Power Cal > Source Cal.
8. Make the following selections in the Source Power Calibration menu:
 - a. Channel 1 = Port 1
 - b. Tolerance = 0.1 dBm
 - c. Maximum number of readings = 50
9. Follow the calibration wizard instructions on the PNA to complete the source power calibration. If necessary, refer to the section titled "Power Calibration" in the embedded Help System of the PNA.
10. After completing the source power calibration, remove the power sensor from the Port 1 cable.
11. Make the following selections to set the PNA receiver attenuator¹ B to 30 dB:
 - a. Select Power > Power and Attenuator.
 - b. Select receiver attenuator B.
 - c. Enter a value of 30 dB.
12. Connect a test cable to Port 2.
13. Connect a thru adapter between Port 1 and Port 2.
14. Normalize the receiver B trace. If necessary, get instructions by searching the embedded Help System of the PNA for "normalize." After normalizing, the trace should be flat at 0 dBm.
15. Remove the thru adapter between the two test cables.

Checking the 85309B Test 1 LO/IF (J3) Channel

16. Connect a test cable between the PNA Port 1 and the 85309B rear panel port LO Input (J1).
17. Connect a test cable between the PNA Port 2 and the 85309B rear panel port Test 1 LO/IF (J3).
18. **For a standard model or Option 00x models only:** Compare the output power traces from the Test 1 LO/IF (J3) port with the limits across the entire frequency range in [Table 2-3 on page 20](#).
19. **For Option 40x models only:**

1. If the PNA receiver does not have an internal step attenuator, an external 30 dB pad attenuator must be connected to Port 2.

- a. Place the 85309B front panel Band Selection switch in the HIGH position, and compare the output power traces with the limits across the entire frequency range in [Table 2-4 on page 22](#).
- b. Place the 85309B front panel Band Selection switch in the LOW position, and compare the output power traces with the limits across the entire frequency range in [Table 2-5 on page 22](#).

20. Set the PNA Port 1 source power to 6 dBm.

21. Repeat step 18 or step 19, as appropriate.

Checking the 85309B Reference LO Out (J2) Channel

22. Connect a test cable between the PNA Port 1 and the 85309B rear panel port LO Input (J1).

23. Connect a test cable between the PNA Port 2 and the 85309B rear panel port Reference LO OUT (J2).

24. Set the PNA Port 1 source power to 0 dBm.

25. **For a standard model or Option 00x models only:** Compare the output power traces from the Reference LO OUT (J2) port with the limits across the entire frequency range in [Table 2-3 on page 20](#).

26. **For Option 40x models only:**

- a. Place the 85309B front panel Band Selection switch in the HIGH position, and compare the output power traces with the limits across the entire frequency range in [Table 2-4 on page 22](#).
- b. Place the 85309B front panel Band Selection switch in the LOW position, and compare the output power traces with the limits across the entire frequency range in [Table 2-5 on page 22](#).

27. Set the PNA Port 1 source power to 6 dBm.

28. Repeat or , as appropriate.

For Option 00x and 40x Models Only: Checking the 85309B Test 2 LO/IF (J11) Channel

29. Connect a test cable between the PNA Port 1 and the 85309B rear panel port LO Input (J1).

30. Connect a test cable between the PNA Port 2 and the 85309B rear panel port Test 2 LO/IF (J11).

31. Set the PNA Port 1 source power to 0 dBm.

32. **For a standard model or Option 00x models only:** Compare the output power traces from the Test 2 LO/IF (J11) port with the limits across the entire frequency range in [Table 2-3 on page 20](#).

33. **For Option 40x models only:**

- a. Place the 85309B front panel Band Selection switch in the HIGH position, and compare the output power traces with the limits across the entire frequency range in [Table 2-4 on page 22](#).
- b. Place the 85309B front panel Band Selection switch in the LOW position, and compare the output power traces with the limits across the entire frequency range in [Table 2-5 on page 22](#).

34. Set the PNA Port 1 source power to 6 dBm.

35. Repeat or , as appropriate.

For Option 002 and 402 Models Only: Checking the 85309B Test 3 LO/IF (J13) Channel

36. Connect a test cable between the PNA Port 1 and the 85309B rear panel port LO Input (J1).

37. Connect a test cable between the PNA Port 2 and the 85309B rear panel port Test 3 LO/IF (J13).

38. Set the PNA Port 1 source power to 0 dBm.

39. **For Option 002 models only:** Compare the output power traces from the Test 3 LO/IF (J13) port with the limits across the entire frequency range in [Table 2-3 on page 20](#).

40. **For Option 402 models only:**

- a. Place the 85309B front panel Band Selection switch in the HIGH position, and compare the output power traces with the limits across the entire frequency range in [Table 2-4 on page 22](#).
- b. Place the 85309B front panel Band Selection switch in the LOW position, and compare the output power traces with the limits across the entire frequency range in [Table 2-5 on page 22](#).

41. Set the PNA Port 1 source power to 6 dBm.

42. Repeat or , as appropriate.

Table 2-3 85309B Standard or Options 001 or 002 Output Power Limits

LO Output Power (+6 dBm Input)	
Frequency Range	Power Level
0.3 – 0.5 GHz	> +21.6 dBm
0.5 – 3 GHz	> +24.1 dBm
3 – 6.2 GHz	> +26.3 dBm
6.2 – 18 GHz	> +23.5 dBm
LO Output Power (0 dBm Input)	

Table 2-3 **85309B Standard or Options 001 or 002 Output Power Limits**

LO Output Power (+6 dBm Input)	
0.3 – 0.5 GHz	> +21.6 dBm
0.5 – 3 GHz	> +23 dBm
3 – 6.2 GHz	> +25 dBm
6.2 – 18 GHz	> +23 dBm

Table 2-4 85309B Options 40x Output Power Limits for HIGH Band

LO Output Power (+6 dBm Input)	
Frequency Range	Power Level
0.3 – 0.5 GHz	> +21.3 dBm
0.5 – 3 GHz	> +22.4 dBm
3 – 6.2 GHz	> +24.4 dBm
6.2 – 18 GHz	> +22 dBm
LO Output Power (0 dBm Input)	
0.3 – 0.5 GHz	> +21.3 dBm
0.5 – 3 GHz	> +22.4 dBm
3 – 6.2 GHz	> +24.4 dBm
6.2 – 18 GHz	> +22 dBm

Table 2-5 85309B Options 40x Output Power Limits for LOW Band

LO Output Power (+6 dBm Input)	
Frequency Range	Power Level
0.1 – 1 GHz	> +14 dBm
LO Output Power (0 dBm Input)	
0.1 – 1 GHz	> +13 dBm

Reference IF and Test IF

After completing the LO Power Output test, use the same cable set and perform the following steps to perform a 2-port calibration and check the Reference IF channels.

1. On the PNA, select Preset.
2. Disconnect the 30 dB pad attenuator, if present.
3. Make the following selections on the PNA:
 - a. Measurement = S21
 - b. Power = -35 dBm
 - c. IF bandwidth = 1 kHz
 - d. Start frequency = 10 MHz
 - e. Stop frequency = 100 MHz
4. Connect a test cable to PNA Port 1.

5. Connect a test cable to PNA Port 2.
6. Connect a thru adapter between the two test cables.
7. Normalize the PNA trace. If necessary, get instructions by searching the embedded Help System of the PNA for “normalize.” After normalizing, the trace should be flat at 0 dBm
8. Remove the thru adapter between the two test cables.

Checking the J10 Reference IF Out

9. Connect the test cable on PNA Port 1 to the 85309B rear panel port Reference IF In (J4).
10. Connect the test cable on PNA Port 2 to the 85309B rear panel port Reference IF Out (J10).
11. Place a marker on the PNA trace. In the frequency range of 10 – 20 MHz, the IF Gain trace should be in the range of +21 dB to +25 dB, +/-0.5 dB. See [Figure 2-8](#) for a typical IF Gain response trace.

Figure 2-8 Typical IF Gain Response Trace

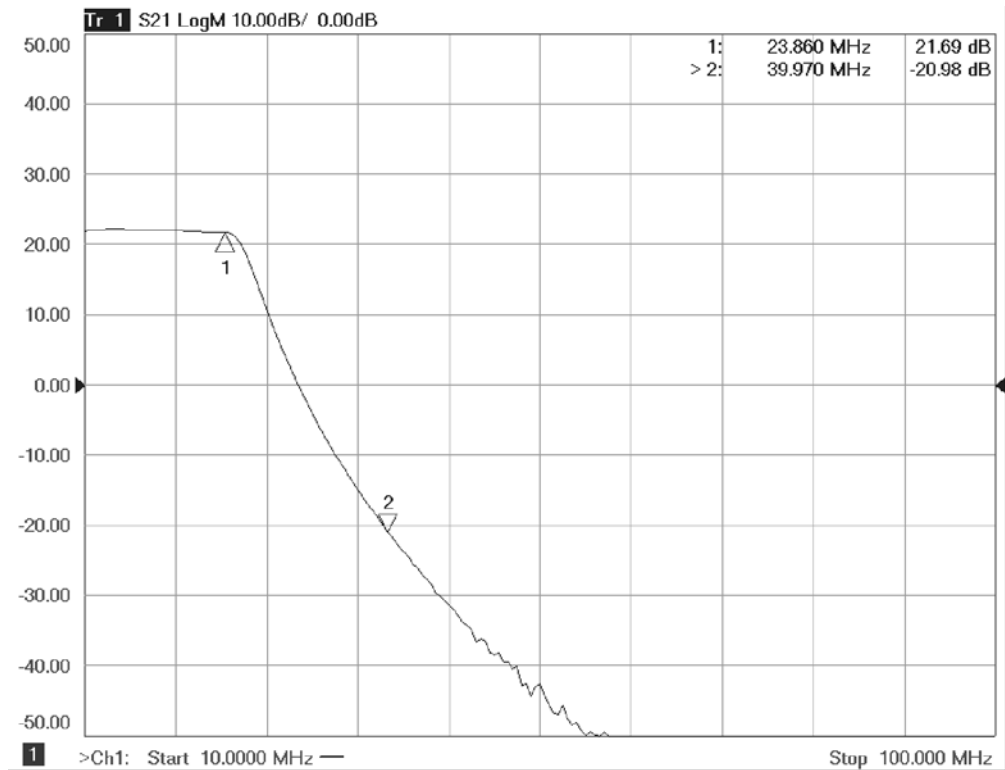

85309_082_24

Checking the J9 Test 1 IF Out

12. Connect a test cable between the PNA Port 1 and the 85309B rear panel port Test 1 LO/IF (J3).

13. Connect a test cable between the PNA Port 2 and the 85309B rear panel port Test 1 IF Out (J9).
14. Verify that the W59 jumper is in place between the J7 and J8 ports on the 85309B rear panel.
15. Place a marker on the PNA trace. In the frequency range of 10 – 20 MHz, the Test IF response trace should be in the range of +21 dB to +25 dB. See [Figure 2-9](#) for a typical Test IF response trace.

Figure 2-9 Typical Test IF Response Trace

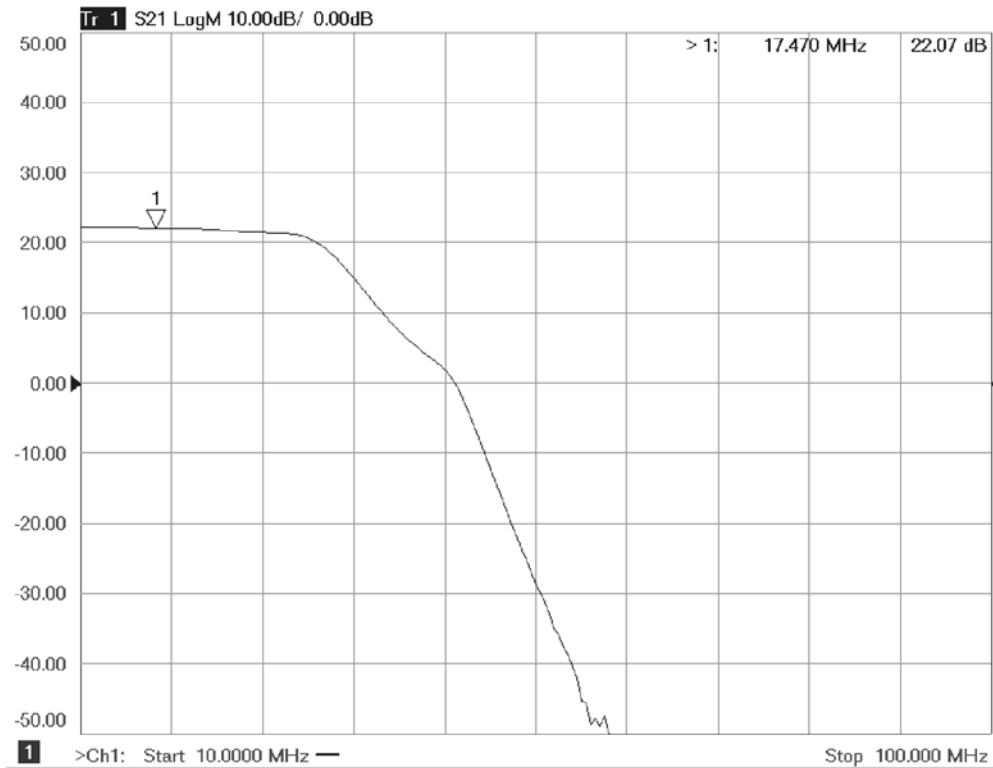

85309_082_25

For Option 00x and 40x Models Only: Checking the J12 Test 2 IF Out

1. Connect a test cable between the PNA Port 1 and the 85309B rear panel port Test 2 LO/IF (J11).
2. Connect a test cable between the PNA Port 2 and the 85309B rear panel port Test 2 IF Out (J12).
3. Place a marker on the PNA trace. In the frequency range of 10 – 20 MHz, the Test IF response trace should be in the range of +21 dB to +25 dB. See [Figure 2-9](#) for a typical Test IF response trace.

For Option 002 and 402 Models Only: Checking the J14 Test 3 IF Out

1. Connect a test cable between the PNA Port 1 and the 85309B rear panel port Test 3 LO/IF (J13).
2. Connect a test cable between the PNA Port 2 and the 85309B rear panel port Test 3 IF Out (J14).
3. Place a marker on the PNA trace. In the frequency range of 10 – 20 MHz, the Test IF response trace should be in the range of +21 dB to +25 dB. See [Figure 2-9](#) for a typical Test IF response trace.

IF the Operator's Check Fails

1. Clean the cables and adapters and repeat the Operator's Check.
2. If the Operator's Check still fails, possibly the amplifiers are biased incorrectly or there is a faulty component. See ["Contacting Keysight" on page 9](#).

Operating Information
Performing the Operator's Check

3 General Information

General Specifications

Environmental:

Operating Temperature Range 0 to 50 °C; for indoor use ONLY

Storage Temperature Range -40 to 70 °C

Operating Altitude 3000 m (9842 ft.)

EMC Complies with the essential requirements of the European EMC Directive as well as current editions of the following standards (dates and editions are cited in the Declaration of Conformity):

* IEC/EN 61326-1

* CISPR Pub 11 Group 1, class A

* AS/NZS CISPR 11

* ICES/NMB-001

This ISM device complies with Canadian ICES-001.

Cet appareil ISM est conforme a la norme NMB-001 du Canada.

South Korean Class A EMC declaration This equipment is Class A suitable for professional use and is for use in electromagnetic environments outside of the home.

A 급 기기 (업무용 방송통신기자재) 이 기기는 업무용 (A 급) 전자파적합기기로서 판매자 또는 사용자는 이 점을 주의하시기 바라 며 , 가정외의 지역에서 사용하는 것을 목적으로 합니다 .

Safety Compliance Complies with the essential requirements of the European Low Voltage Directive as well as current editions of the following standards (dates and editions are cited in the Declaration of Conformity):

* IEC/EN 61010-1

* Canada: CAN/CSA-C22.2 No. 61010-1

* USA: UL Std No. 61010-1

Operating Humidity 95% RH at 40 °C (non-condensing)

Pollution Degree Pollution degree 2

Installation Category **II**

Power Requirements:

Nominal Frequency Range 50/60 Hz

General Information
General Specifications

Nominal Voltage Range	100/120/220/240 Vac (Fluctuation should not exceed +/- 10% of nominal supply voltage)
Power	300 Watts
Weight and Dimensions:	
Net Weight	Std: 9.1 kg Option 001: 9.7 kg Option 002: 10.3 kg Option 400: 9.9 kg Option 401: 10.65 kg Option 402: 11.35 kg
Dimensions	Height: 146 mm Width: 426 mm Depth: 529 mm

CAUTION

Ventilation Requirements: When installing the instrument in a cabinet, the convection into and out of the instrument must not be restricted. The ambient temperature (outside the cabinet) must be less than the maximum operating temperature of the instrument by 4 °C for every 100 watts dissipated in the cabinet. If the total power dissipated in the cabinet is greater than 800 watts, forced convection must be used.

85309B Characteristic Performance

Parameter	Value
Absolute Maximum Rating	
LO input port (CW)	20 dBm
Reference channel IF input port (CW)	13 dBm
Reference channel detector input	±20 VDC
Positive Z/blanking input	±10 VDC
(Option 40x only) Select HIGH/LOW input	±5.5 VDC
Frequency Range	
Low band ¹	0.1 GHz to 1.0 GHz
High band	0.3 GHz to 18.0 GHz
Input Power Range (LO Input Recommended)	
0.1 GHz to 1.0 GHz	6 dBm to 10 dBm
0.3 GHz to 3.0 GHz	6 dBm to 10 dBm
2.0 GHz to 18 GHz	0 dBm to 6 dBm
Minimum Power Output with 0 dBm Input (LO Ports)	
0.1 GHz to 1.0 GHz ¹	13 dBm
0.3 GHz to 0.5 GHz:	21.5 dBm
0.5 GHz to 3.0 GHz:	22.75 dBm
3.0 GHz to 6.2 GHz:	24.75 dBm
6.2 GHz to 18.0 GHz:	22.5 dBm
Output Power Channel Tracking (typical)	
0.1 GHz to 1.0 GHz ¹	±2 dB
0.3 GHz to 18 GHz	±2 dB
Port Return Loss, 0.1 GHz to 18 GHz (typical)	
LO Input	9 dB
LO Output	7 dB

1. Options 40x only.

General Information
85309B Characteristic Performance

Parameter	Minimum	Maximum
IF Channel Small Signal Gain		
20 MHz	21 dB	25 dB

General Safety Considerations

Introduction

Review this product and related documentation to familiarize yourself with safety markings and instructions before you operate the instrument. The documentation contains information and warnings that must be followed by the user to ensure safe operation and to maintain the product in a safe condition.

Cleaning the Instrument

WARNING

To prevent electrical shock, disconnect the Keysight Technologies 85309B from the mains before cleaning. Use a dry cloth or one slightly dampened with water to clean the external case parts. Do not attempt to clean internally.

Connector Care and Cleaning

Cleaning connectors with alcohol shall only be done with the instrument power cord removed, and in a well ventilated area. Allow all residue alcohol moisture to evaporate and the fumes to dissipate prior to energizing the instrument.

WARNING

Keep isopropyl alcohol away from heat, sparks, and flame. Store in a tightly closed container. It is extremely flammable. In case of fire, use alcohol foam, dry chemical, or carbon dioxide; water may be ineffective.

Use isopropyl alcohol with adequate ventilation and avoid contact with eyes, skin, and clothing. It causes skin irritation, may cause eye damage, and is harmful if swallowed or inhaled. It may be harmful if absorbed through the skin. Wash thoroughly after handling.

In case of spill, soak up the sand or earth. Flush spill area with water. Dispose of isopropyl alcohol in accordance with all applicable federal, state, and local environmental regulations.

Declaration of Conformity

A declaration of conformity is available upon request, or a copy is available on the Keysight Technologies Web site at <http://www.keysight.com/go/conformity> or by contacting Keysight – see **“Contacting Keysight” on page 9**.

Statement of Compliance

This instrument has been designed and tested in accordance with IEC Publication 61010, Safety Requirements for Electronic Measuring Apparatus, and has been supplied in a safe condition. The instruction documentation contains information and warnings which must be followed by the user to ensure safe operation and to maintain the instrument in a safe condition.

General Safety Considerations

Ground the Instrument

WARNING

This is a Safety Class I product (provided with a protective earthing ground incorporated in the power cord). The mains plug shall only be inserted in a socket outlet provided with a protective earth contact. Any interruption of the protective conductor, inside or outside of the instrument, will make the instrument dangerous. Intentional interruption is prohibited.

Before Applying Power

Verify that the product is configured to match the available main power source. If this product is to be powered by autotransformer, make sure the common terminal is connected to the neutral (grounded) side of the ac power supply.

Cautions applicable to this instrument.

WARNING

Always use the three-prong AC power cord supplied with this instrument with adequate electric rating. Failure to ensure adequate earth grounding or using a power cord with inadequate rating will impair the safety protection provided by the equipment and make the instrument dangerous.

CAUTION

This product is designed for use in Installation Category II and Pollution Degree 2.

CAUTION

This instrument has autoranging line voltage input; be sure the supply voltage is within the specified range.

CAUTION

Ventilation Requirements: When installing the instrument in a cabinet, the convection into and out of the instrument must not be restricted. The ambient temperature (outside the cabinet) must be less than the maximum operating temperature of the instrument by 4 °C for every 100 watts dissipated in the cabinet. If the total power dissipated in the cabinet is greater than 800 watts, forced convection must be used.

Servicing

Warnings applicable to this instrument.

WARNING

For continued protection against fire hazard replace line fuse only with same type and rating: Fuse 5A/250V, Part Number 2110-0680
The use of other fuses or material is prohibited.

WARNING

Always use the three-prong AC power cord supplied with this instrument with adequate electric rating. Failure to ensure adequate earth grounding or using a power cord with inadequate rating will impair the safety protection provided by the equipment and make the instrument dangerous.

WARNING

This is a Safety Class I product (provided with a protective earthing ground incorporated in the power cord). The mains plug shall be inserted only into a socket outlet provided with a protective earth contact. Any interruption of the protective conductor, inside or outside the product is likely to make the product dangerous. Intentional interruption is prohibited.

WARNING

These servicing instructions are for use by qualified personnel only. To avoid electrical shock, do not perform any servicing unless you are qualified to do so.

WARNING

The opening of covers or removal of parts is likely to expose dangerous voltages. Disconnect the instrument from all voltage sources while it is being opened.

WARNING

This product is designed for use in Installation Category II and Pollution Degree 2.

WARNING

No operator serviceable parts inside. Refer servicing to qualified personnel. To prevent electrical shock do not remove covers.

WARNING

If this product is not used as specified, the protection provided by the equipment could be impaired. This product must be used in a normal condition (in which all means for protection are intact) only.

WARNING

The detachable power cord is the instrument disconnecting device. It disconnects the mains circuits from the mains supply before other parts of the instrument.

Regulatory Information

This section contains information that is required by various government regulatory agencies.

Instrument Markings

Familiarize yourself with these instrument markings and their meanings before operating the instrument.

Table 3-1















	The instruction documentation symbol. The product is marked with this symbol when it is necessary for the user to refer to the instructions in the documentation.
	The AC symbol indicates the required nature of the line module input power.
	This symbol indicates separate collection for electrical and electronic equipment, mandated under EU law as of August 13, 2005. All electric and electronic equipment are required to be separated from normal waste for disposal (Reference WEEE Directive, 2002/96/EC).
	This symbol indicates that the power line switch is ON.
	This symbol indicates that the power line switch is in the OFF position.
	This symbol is used to identify a terminal which is internally connected to the product frame or chassis.
	The CE mark is a registered trademark of the European Community. (If accompanied by a year, it is when the design was proven.)
	Indicates that antistatic precautions should be taken.
	The CSA mark is a registered trademark of the CSA International.
	This mark designates the product is an Industrial Scientific and Medical Group 1 Class A product (reference CISPR 11, Clause 5).
	This is a marking to indicate product compliance with the Canadian Interference-Causing Equipment Standard (ICES-001).
	The RCM mark is a registered trademark of the Australian Communications and Media Authority.

Table 3-1

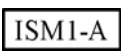
	Indicates the time period during which no hazardous or toxic substance elements are expected to leak or deteriorate during normal use. Forty years is the expected useful life of the product.
	South Korean Certification (KC) mark; includes the marking's identifier code which follows the format: MSIP-REM-YYY- <u>ZZZZZZZZZZZZZZ</u> or KCC-REM-YYY- <u>ZZZZZZZZZZZZ</u> .
	This symbol on all primary or secondary packaging indicates compliance to China standard GB 18455-2001.
IP 20	Degree of protection.

4 Service

Replaceable Parts

Introduction

This section contains information for ordering replaceable parts for the 85309B LO/IF Distribution Unit. The replaceable parts include major assemblies and cables.

Ordering Information

To order a part listed in the replaceable parts lists:

- include the part number
- indicate the quantity required
- Contact Keysight Technologies for instructions on where to send the order. Refer to **“Contacting Keysight” on page 9.**

To order a part **that is not listed** in the replaceable parts lists:

- include the instrument model number and complete instrument serial number
- include the description and function of the part
- indicate the quantity required
- Contact Keysight Technologies for instructions on where to send the order. Refer to **“Contacting Keysight” on page 9.**

Replaceable Parts Listings

Table 4-1 Major 85309B Assemblies (Standard)

Reference Designator	Part Number	Qty	Description
A1	85309-60135	1	PC board, Display
A2	85309-60134	1	PC board, ALC/REG
A10	0955-0791	1	Low pass filter, 30 MHz
A11	0955-2755 ^a Was: 0955-2245	1	Power divider, 18 GHz, 4-way
A12	5087-7755	1	RF amplifier, 0.3 to 18 GHz (Ref Chan)
A13	5087-7755	1	RF amplifier, 0.3 to 18 GHz (Test1 Chan)
A14	85309-80026	1	IF amplifier, 0.5 to 500 MHz (Ref Chan)
A15	85309-80026	1	IF amplifier, 0.5 to 500 MHz (Test1 Chan)
A16	5076-6336 Was 5067-4814*	1	Diplexer (Test1 Chan)
A17	5087-7768	1	RF amplifier, 0.3 to 18 GHz (Input)
A18	85309-61601	1	Potentiometer, 5K ohm + 5PCT 1W 10-Turn Wirebound
A19	5076-6336 Was 5067-4814*	1	Diplexer (Ref Chan)
A22	0950-5271	1	Power supply unit
A43	85110-80015	1	Filter, 30 MHz low pass (Test1 Chan)
AT3	33340-67007	1	Coax, attenuator, sloped (Ref Chan)
AT4	33340-67007	1	Coax, attenuator, sloped (Test1 Chan)
B1	54574-68501	1	Fan assembly
SW1	85309-61607	1	Switch, SPDT

a. Power divider 0955-2755 is used in all instruments with serial number prefixes \geq MY 53351100.

* If any 5067-4814 diplexer is replaced with the 5076-6336 diplexer, you must replace ALL of the other 5067-4814 diplexers as well. You also need to replace the W8 cable 85309-60111 with the 85309-60112 cable.

Figure 4-1 Major 85309B Assemblies (Standard)

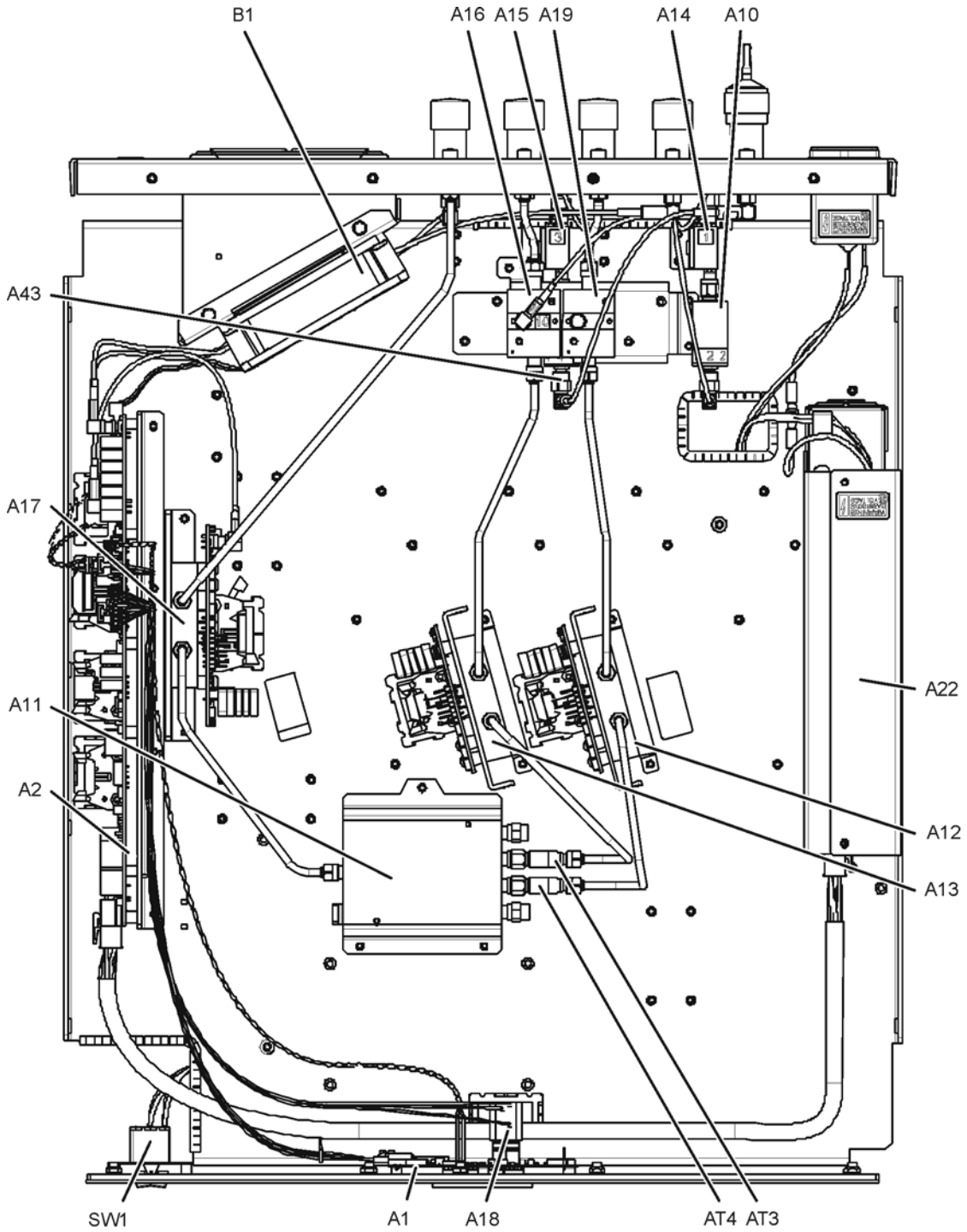

(Some parts removed for clarity.)

85309_082_19

Service
Replaceable Parts

Table 4-2 Cables (Standard)

Reference Designator	Part Number	Qty	Description
W3	85309-20139	1	A17 OUT - A11 IN
W4	85309-20141	1	AT3 OUT - A12 IN
W5	85309-20140	1	AT4 OUT - A13 IN
W7	85309-20144	1	A16 OUT - RPJ3
W8	85309-60112 Was 85309-60111*	1	A16 - RPJ8
W10	85309-20138	1	A17 IN - RPJ1
W11	85309-60109	1	A15 OUT- RPJ9
W12	85309-60109	1	A10 IN- RPJ4
W14	85309-60109	1	A14 OUT- RPJ10
W15	8120-8483	1	A2J1- RPJ5
W16	8120-8483	1	A2J2- RPJ6
W22	85309-20168	1	A12 OUT - A19 IN
W23	85309-20144	1	A19 OUT - RPJ2
W26	85309-20143	1	A13 OUT - A16 IN
W54	8120-5020	1	A2J12 - A17
W58	8120-5067	1	A43 IN - RPJ7
W59	85309-20169	1	Rear Panel Jumper, RPJ7 - RPJ8

*If your current A16 diplexer is 5067-4814, use cable part number 85309-60111.

If your current A16 diplexer is 5076-6336, use cable part number 85309-60112.

Figure 4-2 Cable Locations (Standard)

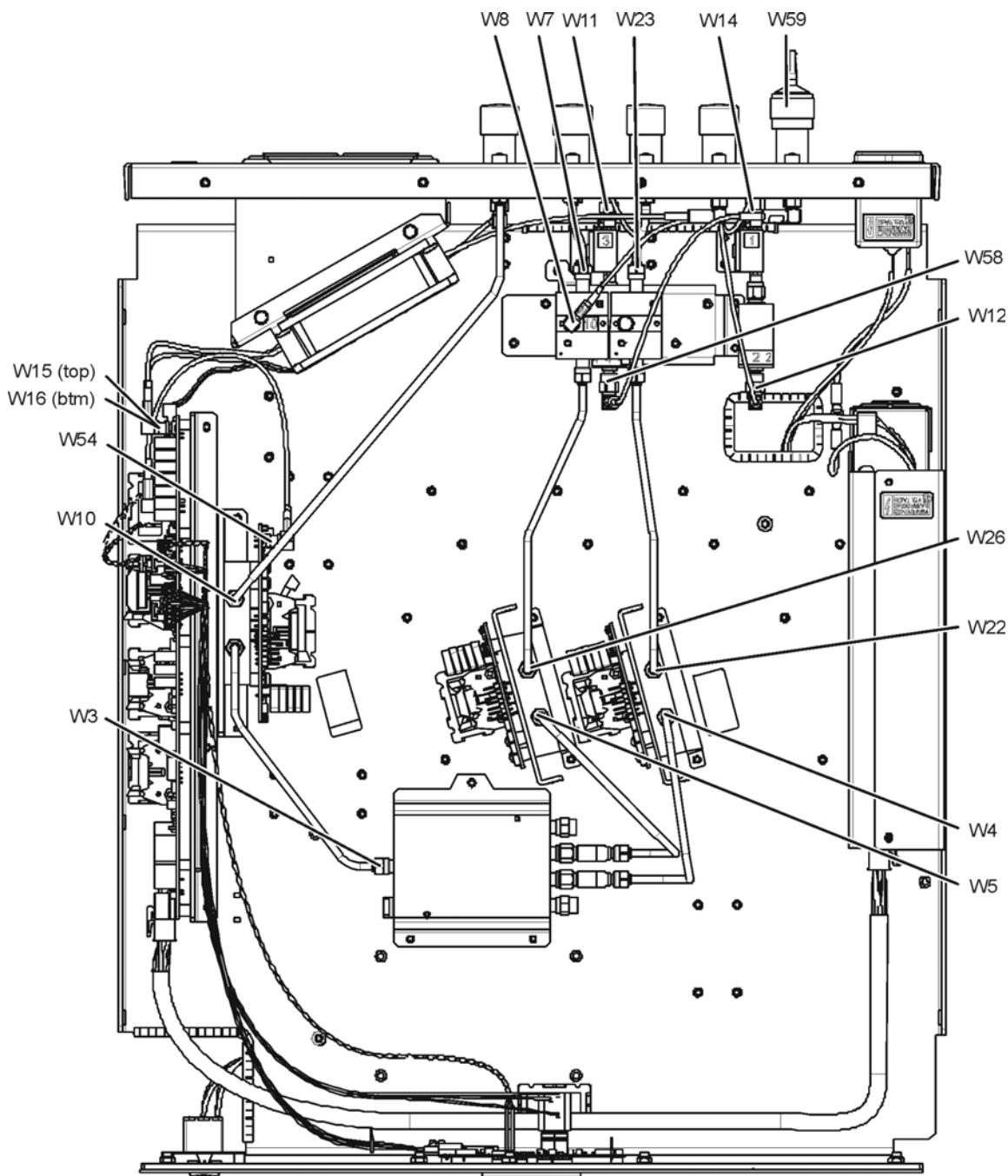

(Some parts removed for clarity.)

85309_082_20

Table 4-3 Major 85309B Assemblies (Option 001)

Reference Designator	Part Number	Qty	Description
A1	85309-60135	1	PC board, Display
A2	85309-60134	1	PC board, ALC/REG
A10	0955-0791	1	Low pass filter, 30 MHz
A11	0955-2755 ^a Was: 0955-2245	1	Power divider, 18 GHz, 4-way
A12	5087-7755	1	RF amplifier, 0.3 to 18 GHz (Ref Chan)
A13	5087-7755	1	RF amplifier, 0.3 to 18 GHz (Test1 Chan)
A14	85309-80026	1	IF amplifier, 0.5 to 500 MHz (Ref Chan)
A15	85309-80026	1	IF amplifier, 0.5 to 500 MHz (Test1 Chan)
A16	5076-6336 Was 5067-4814*	1	Diplexer (Test1 Chan)
A17	5087-7768	1	RF amplifier, 0.3 to 18 GHz (Input)
A18	85309-61601	1	Potentiometer, 5K ohm + 5PCT 1W 10-Turn Wirebound
A19	5076-6336 Was 5067-4814*	1	Diplexer (Ref Chan)
A22	0950-5271	1	Power supply unit
A24	5087-7755	1	RF amplifier, 0.3 to 18 GHz (Test2 Chan)
A25	5076-6336 Was 5067-4814*	1	Diplexer (Test2 Chan)
A26	85309-80026	1	IF amplifier, 0.5 to 500 MHz (Test2 Chan)
A43	85110-80015	1	Filter, 30 MHz low pass (Test1 Chan)
A44	85110-80015	1	Filter, 30 MHz low pass (Test2 Chan)
AT1	33340-67007	1	Coax, attenuator, sloped (Test2 Chan)
AT3	33340-67007	1	Coax, attenuator, sloped (Ref Chan)
AT4	33340-67007	1	Coax, attenuator, sloped (Test1 Chan)
B1	54574-68501	1	Fan assembly
SW1	85309-61607	1	Switch, SPDT

a. Power divider 0955-2755 is used in all instruments with serial number prefixes \geq MY 53351100.

* If any 5067-4814 diplexer is replaced with the 5076-6336 diplexer, you must replace ALL of the other 5067-4814 diplexers as well. You also need to replace the W8 cable 85309-60111 with the 85309-60112 cable.

Figure 4-3 Major 85309B Assemblies (Option 001)

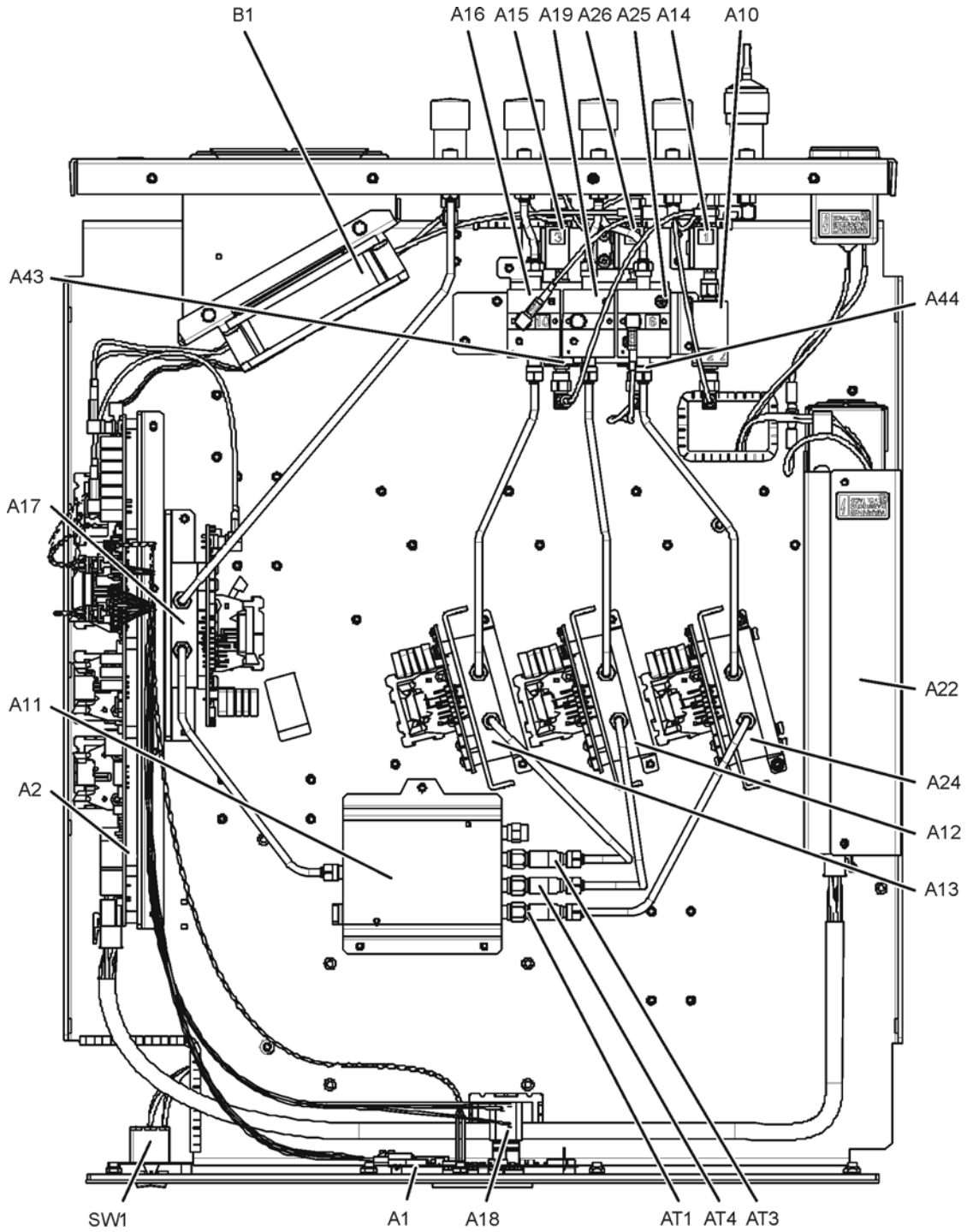

(Some parts removed for clarity.)

85309_082_18

Service
Replaceable Parts

Table 4-4 Cables (Option 001)

Reference Designator	Part Number	Qty	Description
W3	85309-20139	1	A17 OUT - A11 IN
W4	85309-20141	1	AT3 OUT - A12 IN
W5	85309-20140	1	AT4 OUT - A13 IN
W7	85309-20144	1	A16 OUT - RPJ3
W8	85309-60112 Was 85309-60111*	1	A16 - RPJ8
W10	85309-20138	1	A17 IN - RPJ1
W11	85309-60109	1	A15 OUT- RPJ9
W12	85309-60109	1	A10 IN- RPJ4
W14	85309-60109	1	A14 OUT- RPJ10
W15	8120-8483	1	A2J1- RPJ5
W16	8120-8483	1	A2J2- RPJ6
W22	85309-20168	1	A12 OUT - A19 IN
W23	85309-20144	1	A19 OUT - RPJ2
W26	85309-20143	1	A13 OUT - A16 IN
W27	85309-20146	1	A24 OUT - A25 IN
W30	85309-20145	1	AT1 OUT - A24 IN
W32	85309-20147	1	A25 OUT - RPJ11
W33	85309-60111	1	A25 - A44 IN
W34	85309-60109	1	A26 OUT- RPJ12
W54	8120-5020	1	A2J12 - A17
W58	8120-5067	1	A43 IN - RPJ7
W59	85309-20169	1	Rear Panel Jumper, RPJ7 - RPJ8

*If your current A16 diplexer is 5067-4814, use cable part number 85309-60111.

If your current A16 diplexer is 5076-6336, use cable part number 85309-60112.

Figure 4-4 Cable Locations (Option 001)

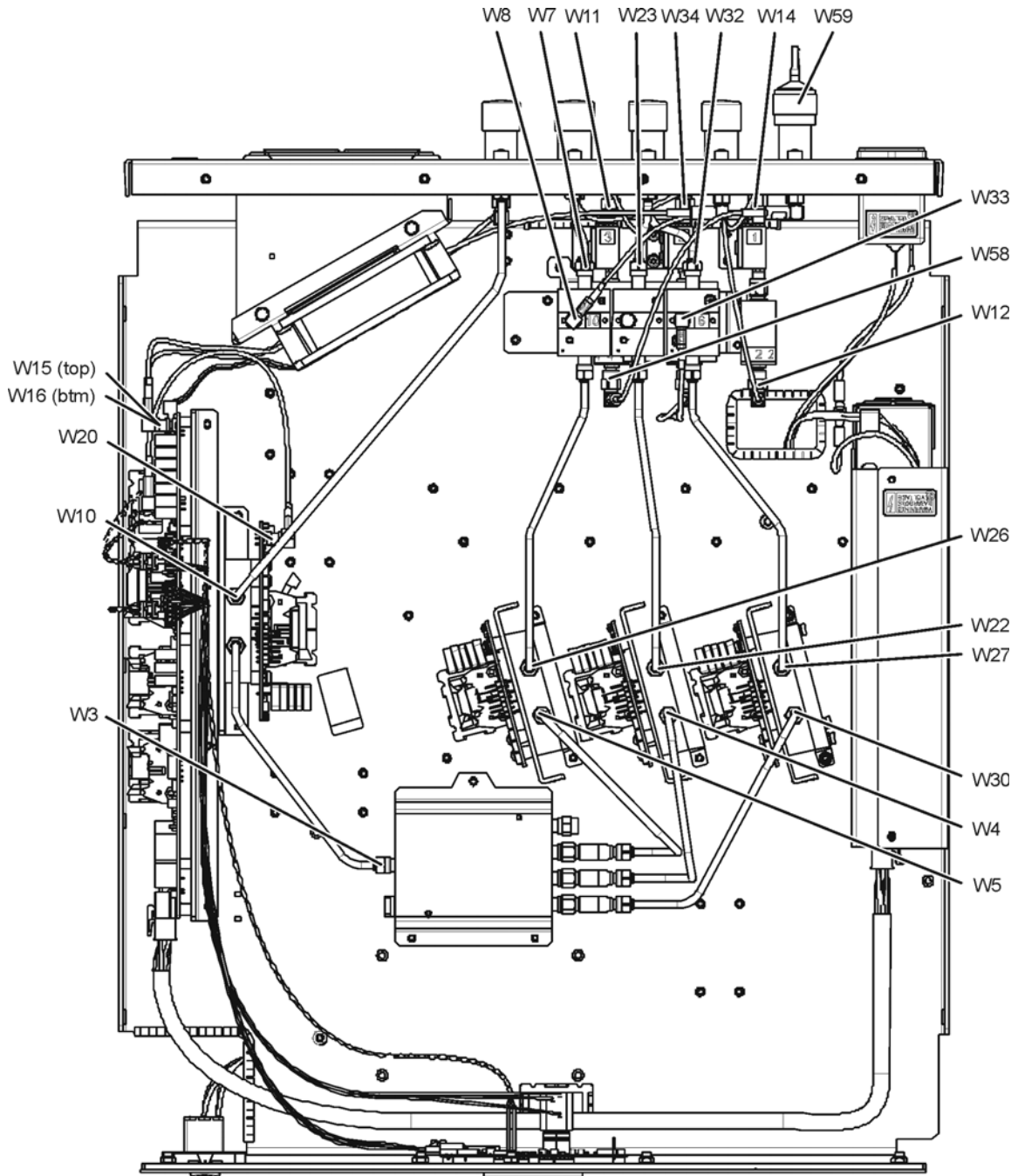

(Some parts removed for clarity.)

85309_082_17

Table 4-5 Major 85309B Assemblies (Option 002)

Reference Designator	Part Number	Qty	Description
A1	85309-60135	1	PC board, Display
A2	85309-60134	1	PC board, ALC/REG
A10	0955-0791	1	Low pass filter, 30 MHz
A11	0955-2755 ^a Was: 0955-2245	1	Power divider, 18 GHz, 4-way
A12	5087-7755	1	RF amplifier, 0.3 to 18 GHz (Ref Chan)
A13	5087-7755	1	RF amplifier, 0.3 to 18 GHz (Test1 Chan)
A14	85309-80026	1	IF amplifier, 0.5 to 500 MHz (Ref Chan)
A15	85309-80026	1	IF amplifier, 0.5 to 500 MHz (Test1 Chan)
A16	5076-6336 Was 5067-4814*	1	Diplexer (Test1 Chan)
A17	5087-7768	1	RF amplifier, 0.3 to 18 GHz (Input)
A18	85309-61601	1	Potentiometer, 5K ohm + 5PCT 1W 10-Turn Wirebound
A19	5076-6336 Was 5067-4814*	1	Diplexer (Ref Chan)
A22	0950-5271	1	Power supply unit
A24	5087-7755	1	RF amplifier, 0.3 to 18 GHz (Test2 Chan)
A25	5076-6336 Was 5067-4814*	1	Diplexer (Test2 Chan)
A26	85309-80026	1	IF amplifier, 0.5 to 500 MHz (Test2 Chan)
A27	5087-7755	1	RF amplifier, 0.3 to 18 GHz (Test3 Chan)
A28	5076-6336 Was 5067-4814*	1	Diplexer (Test3 Chan)
A29	85309-80026	1	IF amplifier, 0.5 to 500 MHz (Test3 Chan)
A43	85110-80015	1	Filter, 30 MHz low pass (Test1 Chan)
A44	85110-80015	1	Filter, 30 MHz low pass (Test2 Chan)
A45	85110-80015	1	Filter, 30 MHz low pass (Test3 Chan)
AT1	33340-67007	1	Coax, attenuator, sloped (Test2 Chan)
AT2	33340-67007	1	Coax, attenuator, sloped (Test3 Chan)
AT3	33340-67007	1	Coax, attenuator, sloped (Ref Chan)
AT4	33340-67007	1	Coax, attenuator, sloped (Test1 Chan)
B1	54574-68501	1	Fan assembly
SW1	85309-61607	1	Switch, SPDT

a. Power divider 0955-2755 is used in all instruments with serial number prefixes \geq MY 53351100.

* If any 5067-4814 diplexer is replaced with the 5076-6336 diplexer, you must replace ALL of the other 5067-4814 diplexers as well. You also need to replace the W8 cable 85309-60111 with the 85309-60112 cable.

Figure 4-5 Major 85309B Assemblies (Option 002)

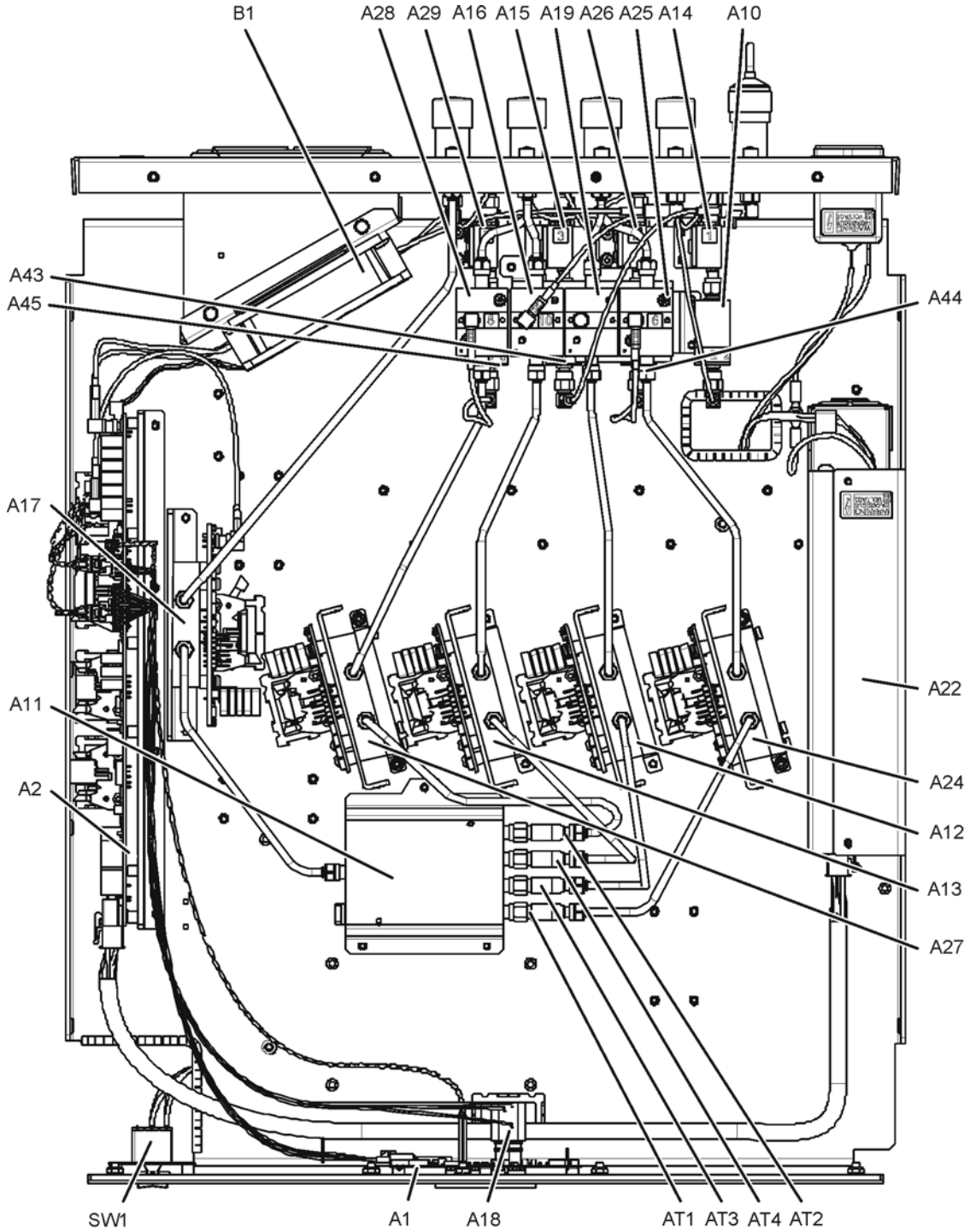

(Some parts removed for clarity.)

85309_082_15

Service
Replaceable Parts

Table 4-6 Cables (Option 002)

Reference Designator	Part Number	Qty	Description
W3	85309-20139	1	A17 OUT - A11 IN
W4	85309-20141	1	AT3 OUT - A12 IN
W5	85309-20140	1	AT4 OUT - A13 IN
W7	85309-20144	1	A16 OUT - RPJ3
W8	85309-60112 Was 85309-60111*	1	A16 - RPJ8
W10	85309-20138	1	A17 IN - RPJ1
W11	85309-60109	1	A15 OUT- RPJ9
W12	85309-60109	1	A10 IN- RPJ4
W14	85309-60109	1	A14 OUT- RPJ10
W15	8120-8483	1	A2J1- RPJ5
W16	8120-8483	1	A2J2- RPJ6
W22	85309-20168	1	A12 OUT - A19 IN
W23	85309-20144	1	A19 OUT - RPJ2
W26	85309-20143	1	A13 OUT - A16 IN
W27	85309-20146	1	A24 OUT - A25 IN
W28	85309-20149	1	A27 OUT - A28 IN
W30	85309-20145	1	AT1 OUT - A24 IN
W32	85309-20147	1	A25 OUT - RPJ11
W33	85309-60111	1	A25 - A44 IN
W34	85309-60109	1	A26 OUT- RPJ12
W35	85309-20148	1	AT2 OUT- A27 IN
W37	85309-20147	1	A28 OUT - RPJ13
W38	85309-60111	1	A28- A45 IN
W39	85309-60109	1	A29 OUT- RPJ14
W54	8120-5020	1	A2J12 - A17
W58	8120-5067	1	A43 IN - RPJ7
W59	85309-20169	1	Rear Panel Jumper, RPJ7 - RPJ8

*If your current A16 diplexer is 5067-4814, use cable part number 85309-60111.

Service
Replaceable Parts

If your current A16 diplexer is 5076-6336, use cable part number 85309-60112.

Figure 4-6 Cable Locations (Option 002)

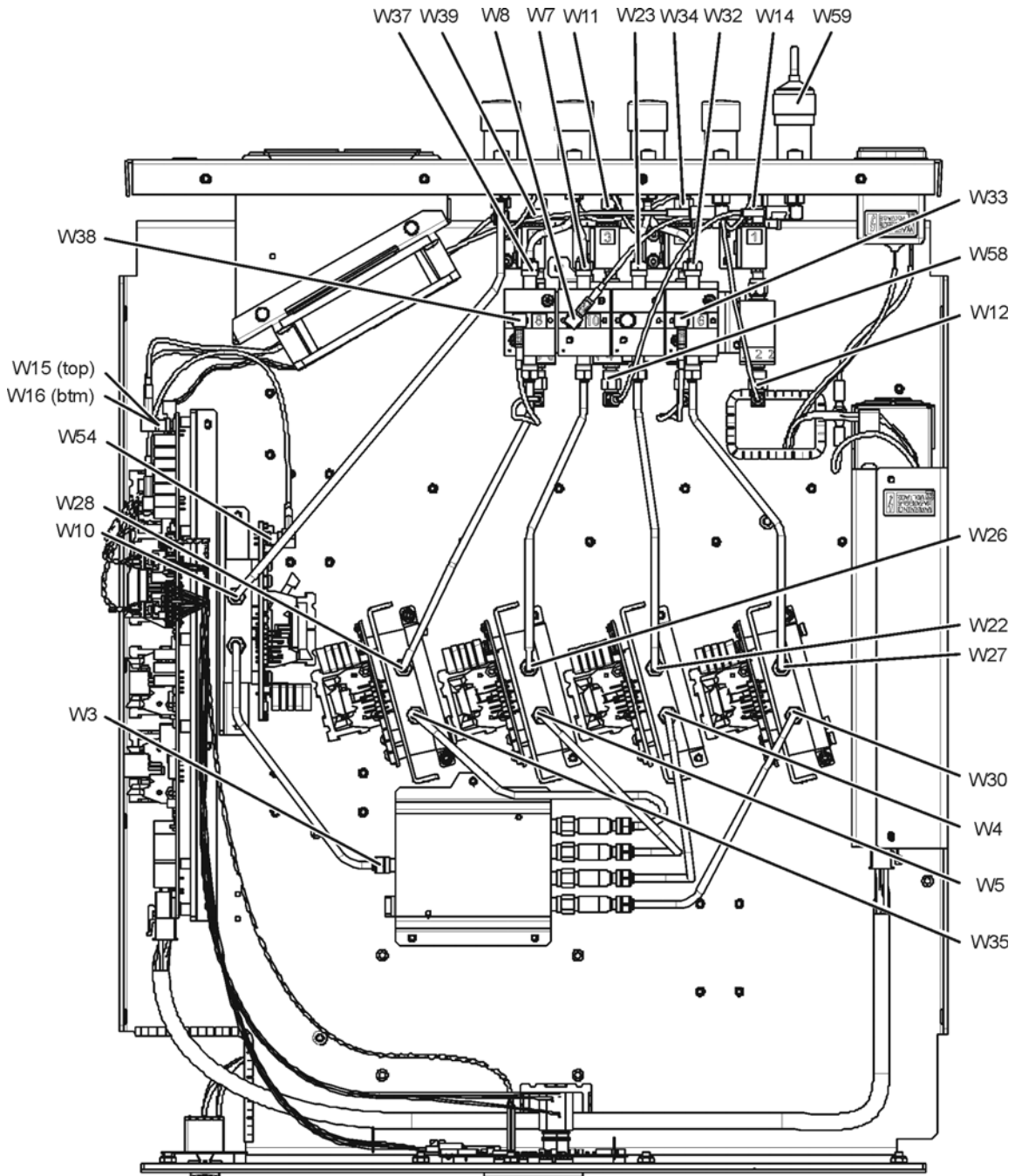

(Some parts removed for clarity.)

85309_082_16

Table 4-7 Major 85309B Assemblies (Option 400)

Reference Designator	Part Number	Qty	Description
A1	85309-60135	1	PC board, Display
A2	85309-60134	1	PC board, ALC/REG
A5	85309-60136	1	PC board, Combi
A10	0955-0791	1	Low pass filter, 30 MHz
A11	0955-2755 ^a Was: 0955-2245	1	Power divider, 18 GHz, 4-way
A12	5087-7755	1	RF amplifier, 0.3 to 18 GHz (Ref Chan)
A13	5087-7755	1	RF amplifier, 0.3 to 18 GHz (Test1 Chan)
A14	85309-80026	1	IF amplifier, 0.5 to 500 MHz (Ref Chan)
A15	85309-80026	1	IF amplifier, 0.5 to 500 MHz (Test1 Chan)
A16	5076-6336 Was 5067-4814*	1	Diplexer (Test1 Chan)
A17	5087-7768	1	RF amplifier, 0.3 to 18 GHz (Input)
A18	85309-61601	1	Potentiometer, 5K ohm + 5PCT 1W 10-Turn Wirebound
A19	5076-6336 Was 5067-4814*	1	Diplexer (Ref Chan)
A22	0950-5271	1	Power supply unit
A30	85309-80024	1	RF amplifier, 10 to 1200 MHz
A31	85309-80025	1	RF amplifier, 10 to 1000 MHz
A32	85309-80022	1	Power divider, 1 GHz, 4way
A36	0955-2249	1	Filter, 100 MHz high pass (Ref Chan)
A38	0955-2249	1	Filter, 100 MHz high pass (Test1 Chan)
A43	85110-80015	1	Filter, 30 MHz low pass (Test1 Chan)
AT3	33340-67007	1	Coax, attenuator, sloped (Ref Chan)
AT4	33340-67007	1	Coax, attenuator, sloped (Test1 Chan)
AT7	0955-2530	1	Microwave attenuator, 6 GHz MAX 1W 1dB SMA (Ref Chan)
AT9	0955-2530	1	Microwave attenuator, 6 GHz MAX 1W 1dB SMA (Test1 Chan)
AT10	0955-1503	1	Microwave attenuator, 18 GHz MAX 2W SMA
B1	54574-68501	1	Fan assembly
SW1	85309-61607	1	Switch, SPDT
SW2	85309-61609	1	Switch, SP3T, rotary
SW3, SW4, SW5	33311-60069	3	Switch, RF SPDT, 15 Vdc 18 GHz

a. Power divider 0955-2755 is used in all instruments with serial number prefixes \geq MY 53351100.

* If any 5067-4814 diplexer is replaced with the 5076-6336 diplexer, you must replace ALL of the other 5067-4814 diplexers as well. You also need to replace the W8 cable 85309-60111 with the 85309-60112 cable.

Figure 4-7 Major 85309B Assemblies (Option 400)

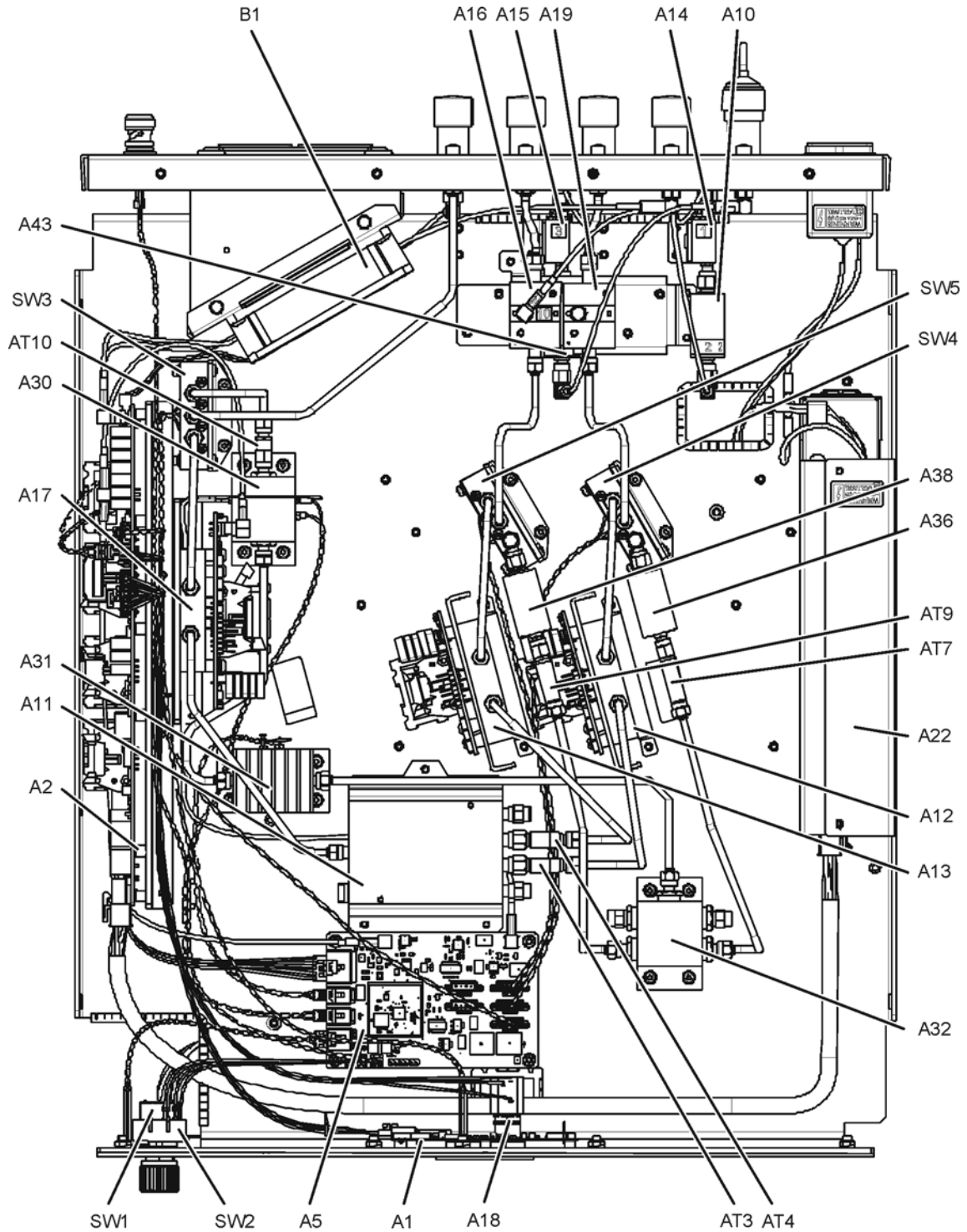

(Some parts removed for clarity.)

85309_082_13

Service
Replaceable Parts

Table 4-8 Cables (Option 400)

Reference Designator	Part Number	Qty	Description
W1	85309-20151	1	RPJ1 - SW3 (C)
W2	85309-20152	1	SW3 (2) - A17 IN
W3	85309-20139	1	A17 OUT - A11 IN
W4	85309-20141	1	AT3 OUT - A12 IN
W5	85309-20140	1	AT4 OUT - A13 IN
W6	85309-20156	1	A13 OUT - SW5 (2)
W7	85309-20144	1	A16 OUT - RPJ3
W8	85309-60112 Was 85309-60111*	1	A16 - RPJ8
W9	85309-20156	1	A12 OUT - SW4 (2)
W11	85309-60109	1	A15 OUT- RPJ9
W12	85309-60109	1	A10 IN- RPJ4
W14	85309-60109	1	A14 OUT- RPJ10
W15	8120-8483	1	A2J1- RPJ5
W16	8120-8483	1	A2J2- RPJ6
W23	85309-20144	1	A19 OUT - RPJ2
W25	8120-5022	1	A2J12 - A5J5
W40	85309-20161	1	SW4 (C) - A19 IN
W41	85309-20153	1	SW3 (1) - AT10 IN
W42	85309-20154	1	A30 OUT - A31 IN
W43	85309-20155	1	A31 OUT - A32 IN
W44	85309-20162	1	AT7 - A32 OUT
W45	85309-20165	1	AT9 - A32 OUT
W47	85309-20167	1	SW5 (C) - A16 IN
W54	8120-5020	1	A2J12 - A17
W58	8120-5067	1	A43 IN - RPJ7
W59	85309-20169	1	Rear Panel Jumper, RPJ7 - RPJ8

*If your current A16 diplexer is 5067-4814, use cable part number 85309-60111.

Service
Replaceable Parts

If your current A16 diplexer is 5076-6336, use cable part number 85309-60112.

Figure 4-8 Cable Locations (Option 400)

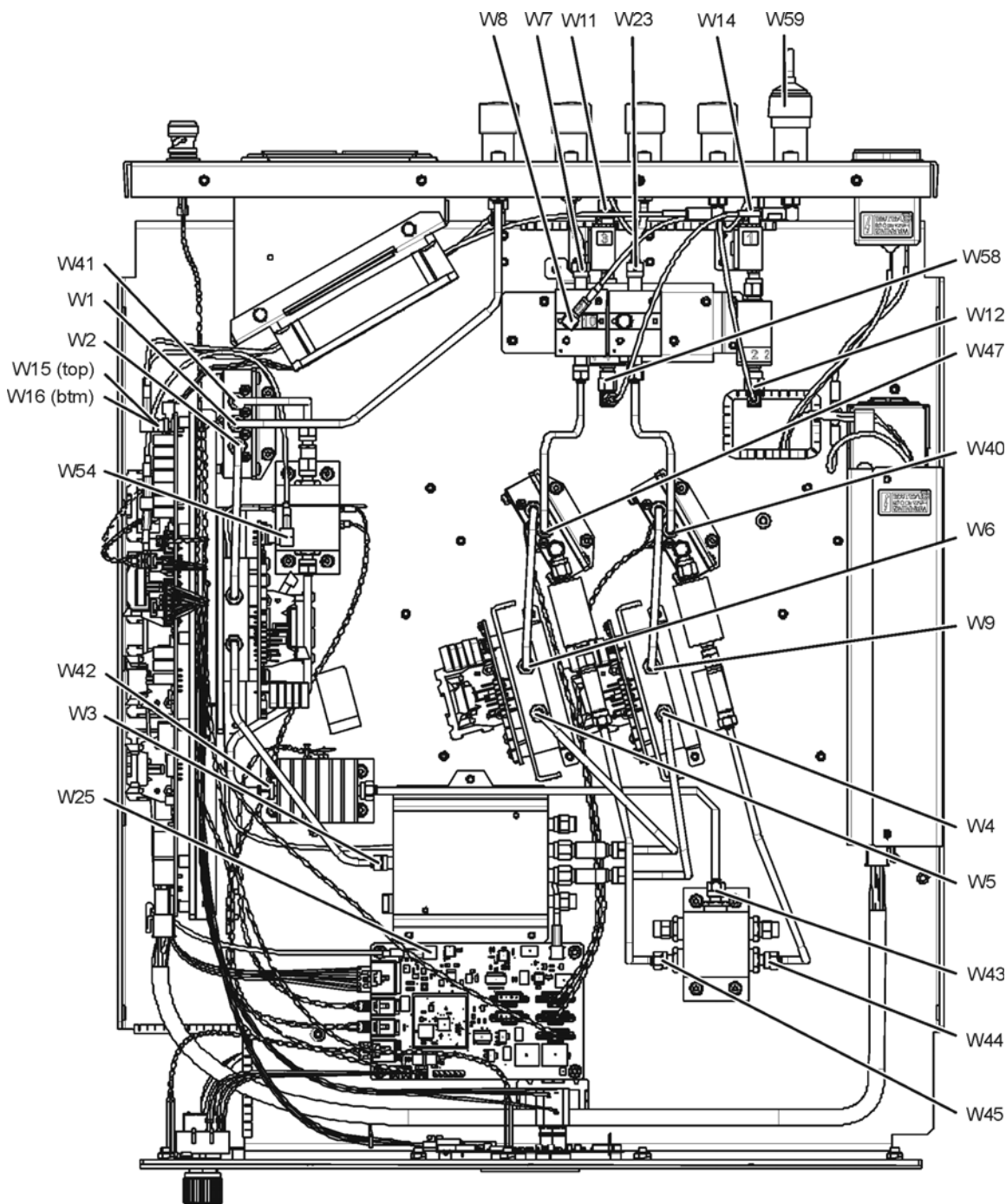

(Some parts removed for clarity.)

85309_082_14

Table 4-9 Major 85309B Assemblies (Option 401)

Reference Designator	Part Number	Qty	Description
A1	85309-60135	1	PC board, Display
A2	85309-60134	1	PC board, ALC/REG
A5	85309-60136	1	PC board, Combi
A10	0955-0791	1	Low pass filter, 30 MHz
A11	0955-2755 ^a Was: 0955-2245	1	Power divider, 18 GHz, 4-way
A12	5087-7755	1	RF amplifier, 0.3 to 18 GHz (Ref Chan)
A13	5087-7755	1	RF amplifier, 0.3 to 18 GHz (Test1 Chan)
A14	85309-80026	1	IF amplifier, 0.5 to 500 MHz (Ref Chan)
A15	85309-80026	1	IF amplifier, 0.5 to 500 MHz (Test1 Chan)
A16	5076-6336 Was 5067-4814*	1	Diplexer (Test1 Chan)
A17	5087-7768	1	RF amplifier, 0.3 to 18 GHz (Input)
A18	85309-61601	1	Potentiometer, 5K ohm + 5PCT 1W 10-Turn Wirebound
A19	5076-6336 Was 5067-4814*	1	Diplexer (Ref Chan)
A22	0950-5271	1	Power supply unit
A24	5087-7755	1	RF amplifier, 0.3 to 18 GHz (Test2 Chan)
A25	5076-6336 Was 5067-4814*	1	Diplexer (Test2 Chan)
A26	85309-80026	1	IF amplifier, 0.5 to 500 MHz (Test2 Chan)
A30	85309-80024	1	RF amplifier, 10 to 1200 MHz
A31	85309-80025	1	RF amplifier, 10 to 1000 MHz
A32	85309-80022	1	Power divider, 1 GHz, 4way
A36	0955-2249	1	Filter, 100 MHz high pass (Ref Chan)
A37	0955-2249	1	Filter, 100 MHz high pass (Test2 Chan)
A38	0955-2249	1	Filter, 100 MHz high pass (Test1 Chan)
A43	85110-80015	1	Filter, 30 MHz low pass (Test1 Chan)
A44	85110-80015	1	Filter, 30 MHz low pass (Test2 Chan)
AT1	33340-67007	1	Coax, attenuator, sloped (Test2 Chan)
AT3	33340-67007	1	Coax, attenuator, sloped (Ref Chan)
AT4	33340-67007	1	Coax, attenuator, sloped (Test1 Chan)
AT7	0955-2530	1	Microwave attenuator, 6 GHz MAX 1W 1dB SMA (Ref Chan)
AT8	0955-2530	1	Microwave attenuator, 6 GHz MAX 1W 1dB SMA (Test2 Chan)
AT9	0955-2530	1	Microwave attenuator, 6 GHz MAX 1W 1dB SMA (Test1 Chan)
AT10	0955-1503	1	Microwave attenuator, 18 GHz MAX 2W SMA
B1	54574-68501	1	Fan assembly
SW1	85309-61607	1	Switch, SPDT
SW2	85309-61609	1	Switch, SP3T, rotary

Table 4-9 Major 85309B Assemblies (Option 401)

Reference Designator	Part Number	Qty	Description
SW3, SW4, SW5, SW6	33311-60069	4	Switch, RF SPDT, 15 Vdc 18 GHz

a. Power divider 0955-2755 is used in all instruments with serial number prefixes \geq MY 53351100.

*If any 5067-4814 diplexer is replaced with the 5076-6336 diplexer, you must replace ALL of the other 5067-4814 diplexers as well. You also need to replace the W8 cable 85309-60111 with the 85309-60112 cable.

Figure 4-9 Major 85309B Assemblies (Option 401)

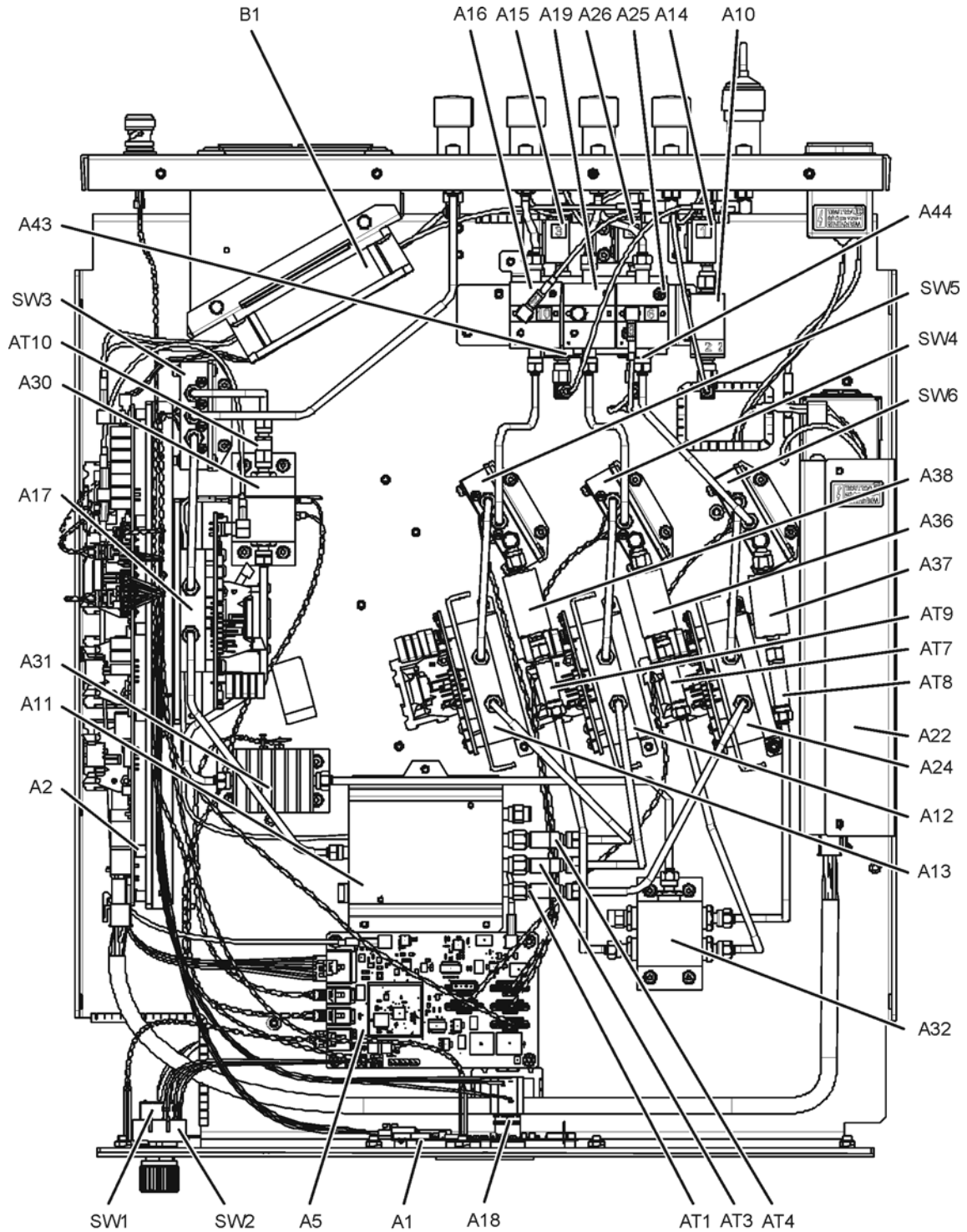

(Some parts removed for clarity.)

85309_082_12

Service
Replaceable Parts

Table 4-10 Cables (Option 401)

Reference Designator	Part Number	Qty	Description
W1	85309-20151	1	RPJ1 - SW3 (C)
W2	85309-20152	1	SW3 (2) - A17 IN
W3	85309-20139	1	A17 OUT - A11 IN
W4	85309-20141	1	AT3 OUT - A12 IN
W5	85309-20140	1	AT4 OUT - A13 IN
W6	85309-20156	1	A13 OUT - SW5 (2)
W7	85309-20144	1	A16 OUT - RPJ3
W8	85309-60112 Was 85309-60111*	1	A16 - RPJ8
W9	85309-20156	1	A12 OUT - SW4 (2)
W11	85309-60109	1	A15 OUT- RPJ9
W12	85309-60109	1	A10 IN- RPJ4
W14	85309-60109	1	A14 OUT- RPJ10
W15	8120-8483	1	A2J1- RPJ5
W16	8120-8483	1	A2J2- RPJ6
W23	85309-20144	1	A19 OUT - RPJ2
W25	8120-5022	1	A2J12 - A5J5
W30	85309-20145	1	AT1 OUT - A24 IN
W31	85309-20156	1	A24 OUT - SW6 (2)
W32	85309-20147	1	A25 OUT - RPJ11
W33	85309-60111	1	A25 - A44 IN
W34	85309-60109	1	A26 OUT- RPJ12
W40	85309-20161	1	SW4 (C) - A19 IN
W41	85309-20153	1	SW3 (1) - AT10 IN
W42	85309-20154	1	A30 OUT - A31 IN
W43	85309-20155	1	A31 OUT - A32 IN
W44	85309-20162	1	AT7 - A32 OUT
W45	85309-20165	1	AT9 - A32 OUT
W47	85309-20167	1	SW5 (C) - A16 IN
W48	85309-20159	1	AT8 - A32 OUT
W49	85309-20164	1	SW6 (C) - A25 IN
W54	8120-5020	1	A2J12 - A17
W58	8120-5067	1	A43 IN - RPJ7
W59	85309-20169	1	Rear Panel Jumper, RPJ7 - RPJ8

Service
Replaceable Parts

*If your current A16 diplexer is 5067-4814, use cable part number 85309-60111.

If your current A16 diplexer is 5076-6336, use cable part number 85309-60112.

Figure 4-10 Cable Locations (Option 401)

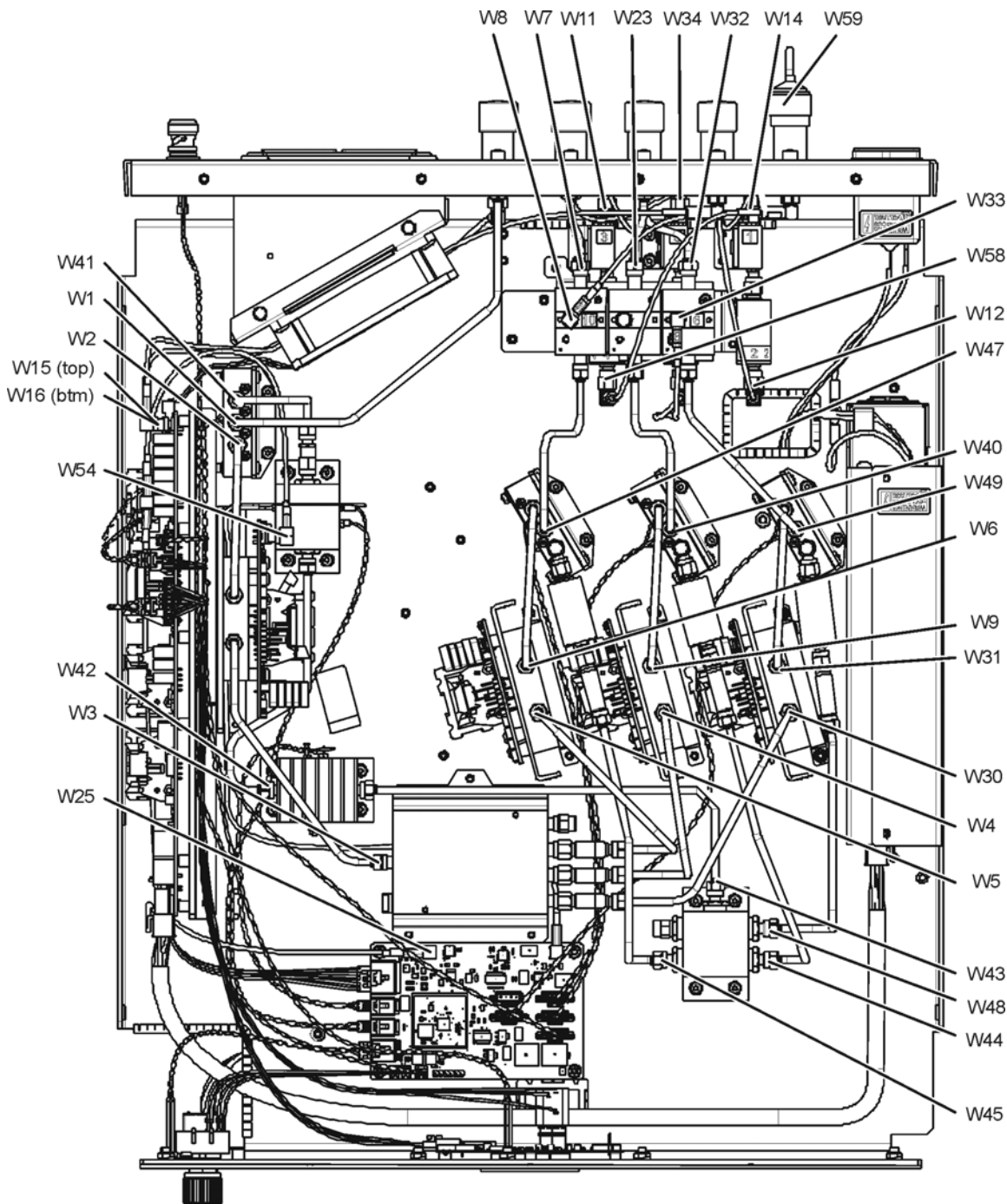

(Some parts removed for clarity.)

85309_082_09

Service
Replaceable Parts

Table 4-11 Major 85309B Assemblies (Option 402)

Reference	Part Number	Qty	Description
A1	85309-60135	1	PC board, Display
A2	85309-60134	1	PC board, ALC/REG
A5	85309-60136	1	PC board, Combi
A10	0955-0791	1	Low pass filter, 30 MHz
A11	0955-2755 ^a Was: 0955-2245	1	Power divider, 18 GHz, 4-way
A12	5087-7755	1	RF amplifier, 0.3 to 18 GHz (Ref Chan)
A13	5087-7755	1	RF amplifier, 0.3 to 18 GHz (Test1 Chan)
A14	85309-80026	1	IF amplifier, 0.5 to 500 MHz (Ref Chan)
A15	85309-80026	1	IF amplifier, 0.5 to 500 MHz (Test1 Chan)
A16	5076-6336 Was 5067-4814*	1	Diplexer (Test1 Chan)
A17	5087-7768	1	RF amplifier, 0.3 to 18 GHz (Input)
A18	85309-61601	1	Potentiometer, 5K ohm + 5PCT 1W 10-Turn Wirebound
A19	5076-6336 Was 5067-4814*	1	Diplexer (Ref Chan)
A22	0950-5271	1	Power supply unit
A24	5087-7755	1	RF amplifier, 0.3 to 18 GHz (Test2 Chan)
A25	5076-6336 Was 5067-4814*	1	Diplexer (Test2 Chan)
A26	85309-80026	1	IF amplifier, 0.5 to 500 MHz (Test2 Chan)
A27	5087-7755	1	RF amplifier, 0.3 to 18 GHz (Test3 Chan)
A28	5076-6336 Was 5067-4814*	1	Diplexer (Test3 Chan)
A29	85309-80026	1	IF amplifier, 0.5 to 500 MHz (Test3 Chan)
A30	85309-80024	1	RF amplifier, 10 to 1200 MHz
A31	85309-80025	1	RF amplifier, 10 to 1000 MHz
A32	85309-80022	1	Power divider, 1 GHz, 4way
A36	0955-2249	1	Filter, 100 MHz high pass (Ref Chan)
A37	0955-2249	1	Filter, 100 MHz high pass (Test2 Chan)
A38	0955-2249	1	Filter, 100 MHz high pass (Test1 Chan)
A43	85110-80015	1	Filter, 30 MHz low pass (Test1 Chan)
A44	85110-80015	1	Filter, 30 MHz low pass (Test2 Chan)
A45	85110-80015	1	Filter, 30 MHz low pass (Test3 Chan)
A46	0955-2249	1	Filter, 100 MHz high pass (Test3 Chan)
AT1	33340-67007	1	Coax, attenuator, sloped (Test2 Chan)
AT2	33340-67007	1	Coax, attenuator, sloped (Test3 Chan)
AT3	33340-67007	1	Coax, attenuator, sloped (Ref Chan)
AT4	33340-67007	1	Coax, attenuator, sloped (Test1 Chan)
AT7	0955-2530	1	Microwave attenuator, 6 GHz MAX 1W 1dB SMA (Ref Chan)
AT8	0955-2530	1	Microwave attenuator, 6 GHz MAX 1W 1dB SMA (Test2 Chan)
AT9	0955-2530	1	Microwave attenuator, 6 GHz MAX 1W 1dB SMA (Test1 Chan)

Table 4-11 Major 85309B Assemblies (Option 402)

Reference	Part Number	Qty	Description
AT10	0955-1503	1	Microwave attenuator, 18 GHz MAX 2W SMA
AT11	0955-2530	1	Microwave attenuator, 6 GHz MAX 1W 1dB SMA (Test3 Chan)
B1	54574-68501	1	Fan assembly
SW1	85309-61607	1	Switch, SPDT
SW2	85309-61609	1	Switch, SP3T, rotary
SW3 - SW7	33311-60069	5	Switch, RF SPDT, 15 Vdc 18 GHz

a. Power divider 0955-2755 is used in all instruments with serial number prefixes \geq MY 53351100.

* If any 5067-4814 diplexer is replaced with the 5076-6336 diplexer, you must replace ALL of the other 5067-4814 diplexers as well. You also need to replace the W8 cable 85309-60111 with the 85309-60112 cable.

Figure 4-11 Major 85309B Assemblies (Option 402)

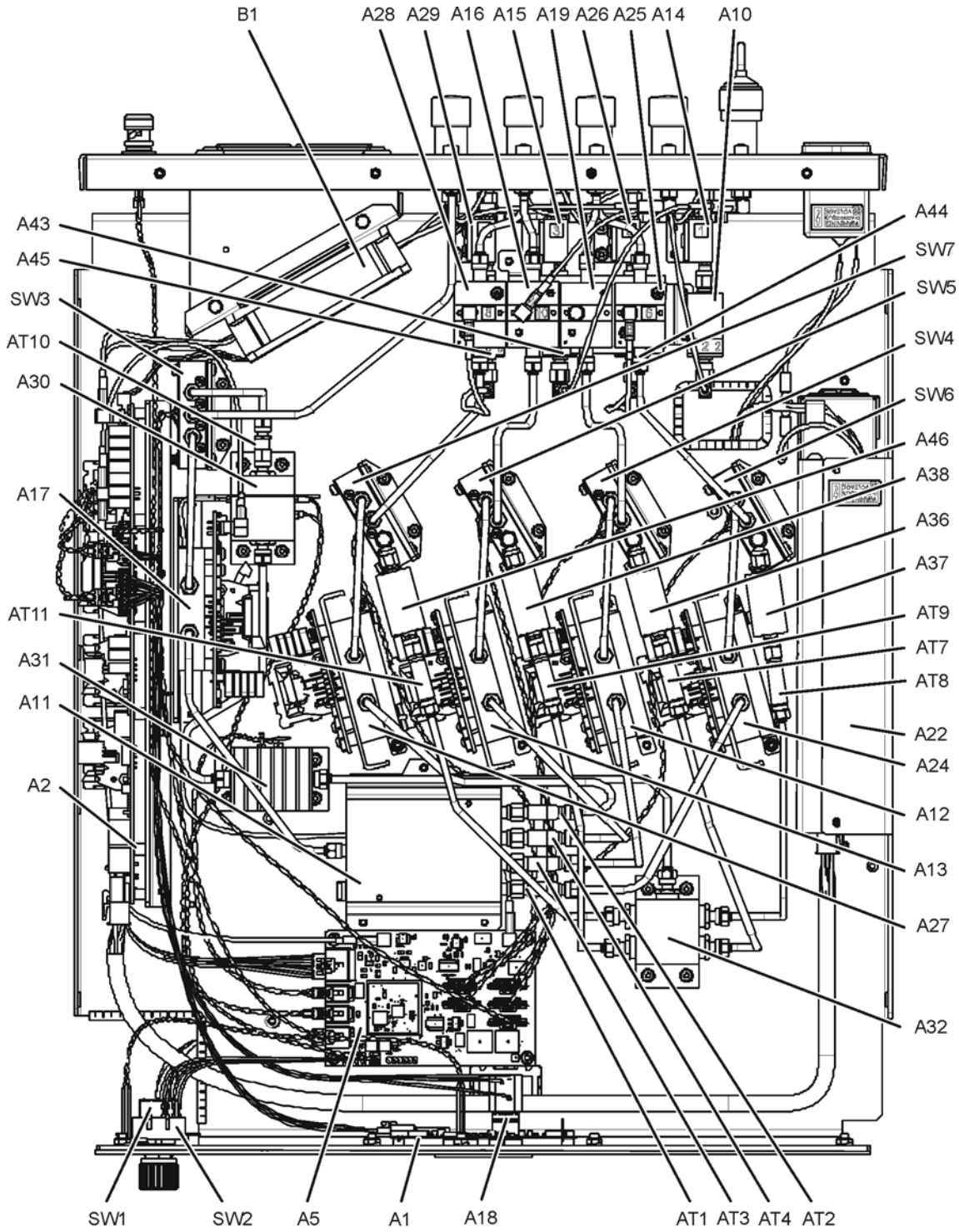

(Some parts removed for clarity.)

85309_082_10

Service
Replaceable Parts

Table 4-12 Cables (Option 402)

Reference Designator	Part Number	Qty	Description
W1	85309-20151	1	RPJ1 - SW3 (C)
W2	85309-20152	1	SW3 (2) - A17 IN
W3	85309-20139	1	A17 OUT - A11 IN
W4	85309-20141	1	AT3 OUT - A12 IN
W5	85309-20140	1	AT4 OUT - A13 IN
W6	85309-20156	1	A13 OUT - SW5 (2)
W7	85309-20144	1	A16 OUT - RPJ3
W8	85309-60112 Was 85309-60111*	1	A16 - RPJ8
W9	85309-20156	1	A12 OUT - SW4 (2)
W11	85309-60109	1	A15 OUT- RPJ9
W12	85309-60109	1	A10 IN- RPJ4
W14	85309-60109	1	A14 OUT- RPJ10
W15	8120-8483	1	A2J1- RPJ5
W16	8120-8483	1	A2J2- RPJ6
W23	85309-20144	1	A19 OUT - RPJ2
W25	8120-5022	1	A2J12 - A5J5
W30	85309-20145	1	AT1 OUT - A24 IN
W31	85309-20156	1	A24 OUT - SW6 (2)
W32	85309-20147	1	A25 OUT - RPJ11
W33	85309-60111	1	A25 - A44 IN
W34	85309-60109	1	A26 OUT- RPJ12
W35	85309-20148	1	AT2 OUT - A27 IN
W36	85309-20156	1	A27 OUT - SW7 (2)
W37	85309-20147	1	A28 OUT - RPJ13
W38	85309-60111	1	A28 - A45 IN
W39	85309-60109	1	A29 OUT- RPJ14
W40	85309-20161	1	SW4 (C) - A19 IN
W41	85309-20153	1	SW3 (1) - AT10 IN
W42	85309-20154	1	A30 OUT - A31 IN
W43	85309-20155	1	A31 OUT - A32 IN
W44	85309-20162	1	AT7 - A32 OUT
W45	85309-20165	1	AT9 - A32 OUT
W47	85309-20167	1	SW5 (C) - A16 IN
W48	85309-20159	1	AT8 - A32 OUT
W49	85309-20164	1	SW6 (C) - A25 IN
W50	85309-20158	1	A11 - A32 OUT
W51	85309-20157	1	SW7 (C) - A28 IN
W54	8120-5020	1	A2J12 - A17
W58	8120-5067	1	A43 IN - RPJ7
W59	85309-20169	1	Rear Panel Jumper, RPJ7 - RPJ8

Service
Replaceable Parts

*If your current A16 diplexer is 5067-4814, use cable part number 85309-60111.

If your current A16 diplexer is 5076-6336, use cable part number 85309-60112.

Figure 4-12 Cable Locations (Option 402)

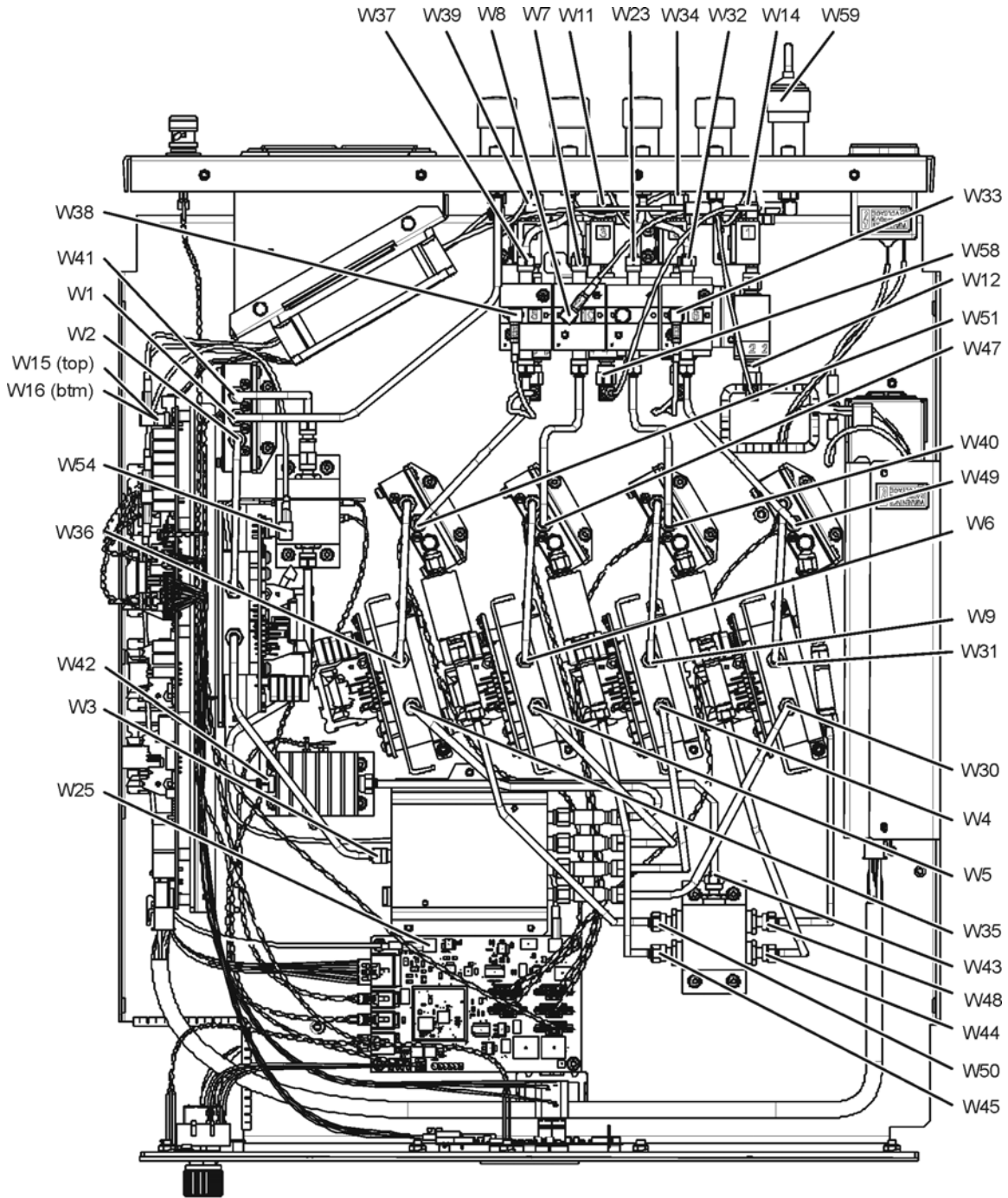

(Some parts removed for clarity.)

85309_082_11

Service
Replaceable Parts



This information is subject to change without notice.

© Keysight Technologies 2008-2016

August 2016



85309-90082

www.keysight.com