

# MANUAL

---



## EFM 023 BGT and Audit Kits

---

*System Prof. Dr.-Ing. Hans Kleinwächter*

Walking Test with EFM 023 and UAC 110

## Contents

General information on electrostatics.....	3
Origin of electrostatic charge .....	3
Product description.....	3
Specifications .....	4
Measuring range Voltmeter .....	4
Measuring range E-Field Meter .....	4
Caption .....	5
Operating instructions .....	6
Measuring principle .....	6
Application Areas .....	6
Button Features .....	6
Initiation .....	6
Hold.....	6
Measurement ranges .....	7
E-Field Meter Measurement .....	7
Max. Value .....	7
Analogue Output.....	7
Changing the measurement distance.....	8
Spacers.....	8
Display .....	9
Battery Monitoring.....	9
Grounding.....	9
Maintenance .....	9
Battery Replacement .....	10
Zero Point.....	10
Guarantee Items.....	10
Batteries and accumulators are not allowed in the household waste! .....	10
Electrical and electronic equipment are not allowed in the household waste! .....	10
Walking Test .....	11
Product Instruction .....	11
Caption.....	12
Daten Specifications.....	12
Operating instructions .....	13
Measuring process.....	13
Walking test with UAC 110 on a PC :.....	14

Scope of Delivery.....	14
Calibration.....	14
Warning Notices .....	15
<i>Ad-On facilities</i> :.....	15
Audit Kit 1 - CPM .....	15
Additional Scope of Delivery .....	15
Audit Kit 2 - Complete.....	16
Additional Scope of Delivery .....	16

## General information on electrostatics

Nowadays ESD<sup>1</sup> is a problem at many workstations, because modern microelectronics<sup>2</sup> is easily destroyed by the sequels of ESD. Other branches of industry like e.g. telecommunications-, plastics-, and explosive material industry are also heavily affected by ESD.

ESD causes losses of time as well as high financial losses and can endanger the human health. Charges of over 10000 Volts can emerge on people, clothes, materials and equipment. Devices that are sensitive to electrostatics can be damaged by electrostatic discharges of less than 100 Volts. Charges of 3000 Volts and more can cause sparks. In endangered areas that can cause explosions.

### Origin of electrostatic charge

Triboelectricity<sup>3</sup> is caused by attrition of different materials. Electrons are transferred from one material to the other. As electrons are charged negative the material that releases electrons is charged positive. The material admitting electrons is charged negative. There are different ways to avoid or to discharge electrostatic charges. But to find an effective and reasonable solution first of all the emergence, amount and polarity of the charge have to be found. Our devices are suitable for that purpose and for the supervision of favored charge.

## Product description

The unit is housed into an EMV plastic enclosure. The influence electrode is star shaped. In front of it in a small distance apart a rotating grounded modulation propeller with the same shape as the electrode is located. The influence electrode is enclosed by a ring electrode system that is used as mechanical shield for the propeller wheel and the sensor plate. A 2×12 digit alpha-numeric LC display is located at the front of the device.

The device has an integrated micro computer with the following functions:

- Conversion of the measured field intensity over the adjusted measurement distance to the charge in Volts
- one button operation

---

<sup>1</sup> electrostatic discharge

<sup>2</sup> integrated circuits

<sup>3</sup> Greek: tribeia = friction

- permanent supervision of the battery voltage with automatic shut-down
- charge plate mode<sup>4</sup>
- pos. and neg. Maximum Value memory<sup>5</sup>

## Specifications

<b>Dimensions (L x W x H):</b>	Approx. 70mm x 122mm x 26mm
<b>Weight:</b>	Approx. 130g
<b>Calibration in parallel plate capacitor:</b>	200mm x 200mm, distance 20mm
<b>Calibration accuracy:</b>	< 5%
<b>Output Voltage:</b> Only in "E-Field" Mode	± 1V (Ri>1kOhm)
<b>Digital/Analogue Converter DAC</b>	Resolution 10Bit
<b>Battery:</b>	9V alkaline or NiMH battery
<b>Operating time:</b>	Approx. 10h with alkaline battery

## Measuring range Voltmeter

Distance	Measuring range	Max. resolution
1cm	0 ... 10kV	1V
2cm	0 ... 20kV	2V
5cm	0 ... 50kV	5V
10cm	0 ... 100kV	10V
20cm	0 ... 200kV	20V

## Measuring range E-Field Meter

Manual Range	*Measuring range	Max. resolution
± 20 kV/m	± 1V	20V/m
± 200 kV/m	± 1V	200V/m
± 1 MV/m	± 1V	1kV/m

**\* DAC only switched on in manual E-Field Meter Mode !**  
**In all other modes the DAC Output is 0V**

<sup>4</sup> with optional CPS kit

<sup>5</sup> walking test

## Caption

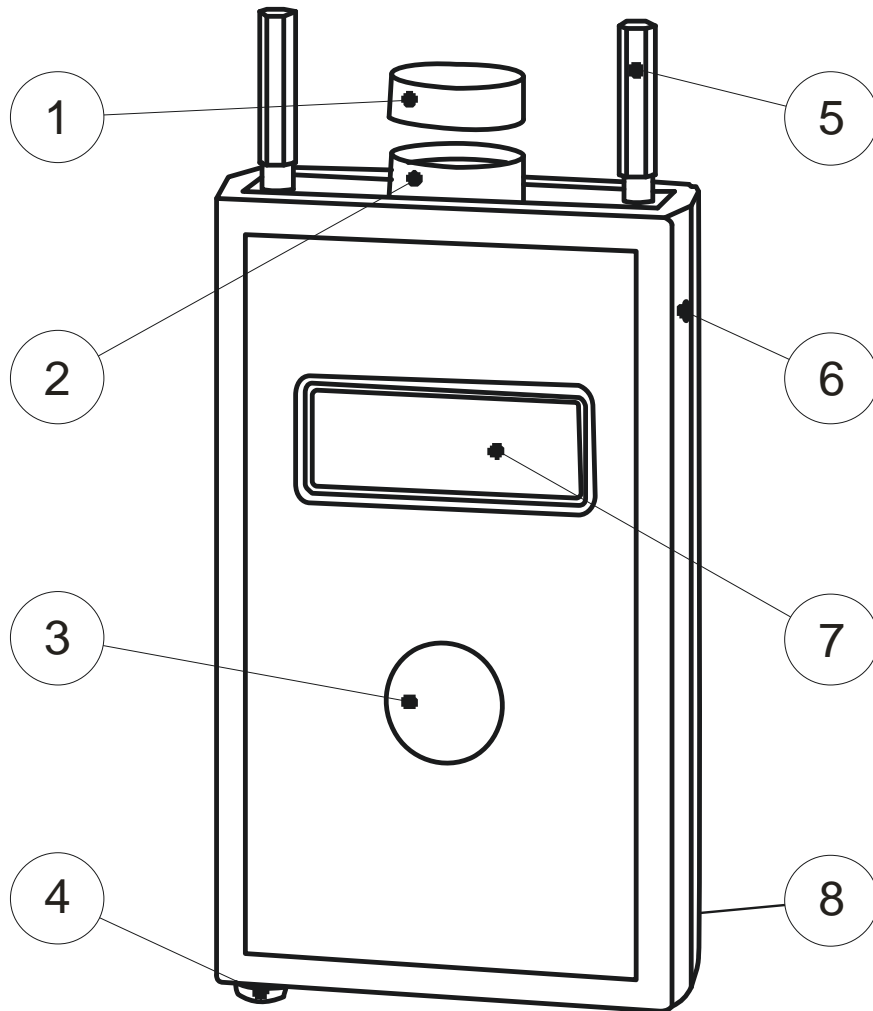

- |   |                      |   |                            |
|---|----------------------|---|----------------------------|
| 1 | Cover cap            | 5 | Spacer                     |
| 2 | Modulator system     | 6 | Zero point trimmer         |
| 3 | Button «function/on» | 7 | Alphanumeric LCD display   |
| 4 | Grounding jack       | 8 | Battery case (on the back) |

## Operating instructions

### Measuring principle

The electrostatic field meter is a parametric amplifier. The electric field influences a current proportional to the electrostatic field. The current is amplified and measured with a selective amplifier. No energy is taken from the field over time means.

*No radioactive matters are used!*

---

### Application Areas

*Detection and Control of electrostatic fields resp. charges, measuring of electric charges, electrostatic charges, very high-resistance voltage sources.*

### Button Features

On	Press «function/on» 1 time shortly
Hold	Press «function/on» 1 time shortly to switch on or off
Distance	Press «function/on» until „change cm“ appears Press «function/on» 1 time shortly to change to a new distance or to CPS mode, wait approx. 2s to select the displayed function
Aus	Press «function/on» 2 times in quick succession

### Initiation

By pressing the «function/on» button on the front panel the device is switched on. By pressing the «function/on» button twice in normal operation the device is switched off.

**The black cover cap on the modulator system has to be removed before measuring!**

If the «function/on» button is not pressed for about 3.5 min, the device switches off to save power and to prevent discharge of the accumulator.

### Hold

The device has a hold function to freeze the current measuring value. By pressing the «function/on» one time the value measured at that time remains in the display. The upper line shows „Hold“ and in the bottom line the result is displayed. By pressing the «function/on» button again the hold function is switched off and the current result is displayed.

## Measurement ranges

After switching the device on the distance selected distance is 2cm. If you want to measure with that distance<sup>6</sup> you just have to place the device 2cm in front of the object to be measured. For most cases this distance is ideal because charges up to 20kV can be measured (see specifications). But there are cases in which the measuring distance should be changed. In case of very high charges or very rough surfaces the distance should be increased. In case of very low charges the smallest distance (1cm) should be selected.

When the instrument switched off in the E-Field Meter Mode, it switches on in this Modus with the last selected Range.

## E-Field Meter Measurement

The unit can display the E-Field strength directly. By “change distance” (see downsize) select the E-Field Meter Mode. In this Mode it’s possible to select the following ranges  $\pm 20\text{KV/m}$ ,  $\pm 200\text{kV/m}$  or  $\pm 1\text{MV/m}$ . To change the ranges press the «function/on» key shortly. The range changed as following:



In this Mode there is no automatically change of the range. That’s why the DAC is now active.

## Max. Value

The unit display in the “Max. Value” Mode in the upper row the maximum positive (right) and negative (left) Value. The “Hold” Function is in this case out of order. By shortly pressing the «function/on» key the maximum values will be erased and this function start again.

## Analogue Output

The instrument has a DAC – Output interface with  $\pm 1\text{V}$  proportional to the measured electric field strength. By exceeding more as 20% of the end range value “Over range” is displayed.

An analogue output is only useful in a manual range setting, that’s why it is only active in manual E-Field Modus. In any other modes the DAV is deactivated and on the output always is “0V”.

---

<sup>6</sup> According to the spacers

## Changing the measurement distance

Press «function/on» until the lower line shows „change distance“ (approx. 2 sec). In the upper line the current distance is shown in cm. By pressing «function/on» the distance can be changed in the following order:



To select the displayed value wait (without pressing «function/on») until the current measurement value is displayed in the bottom line. In the upper line the new distance is displayed. Continue measuring using the new distance. The distance is measured from the plate behind the modulator blade. The plate is located 6.4mm in front of the devices front plane.

***\*After switching the device off and on always 2cm distance are selected***

---

\* Without the manual "E-Field Mode"

The electrostatic field meter measures the direct voltage field strength all the time. Over the selected distance the field strength is converted to the charge on the object:

$$\text{displayed value [V]} = \text{field strength [V/m]} \times \text{distance [m]}$$

Example:

With a distance of 10cm and a displayed value of 1000V the field strength is:

$$\mathbf{E = 1.000V / 0,1m = 10.000 V/m}$$

## Spacers

The shipment includes 2 spacers for the measurement distance 2cm. Those can be screwed in the front plate.



## Display

The display is a double-spaced alphanumeric LCD display with 12 digits in each row (2 x 12). In the upper line the selected distance is displayed in cm. In the bottom line the measured charge is displayed in Volt. Over 999V on the display changes to kV display.

The displayed value is always triple-digit:

Examples:



If the measure field strength is too high „overflow! “ is displayed, the distance has to be increased.

## Battery Monitoring

The device has permanent battery voltage monitoring. By undercutting a battery voltage of 7.6V the upper line displays: „Low Battery!“. In that case the 9V battery has to be charged or renewed. By undercutting 7.1V the display shows “auto off” for about 2s and the device powers off to prevent further damage.

### Attention:

Use only Rechargeable 9V – NiMH Battery !

Batteries have to be charged outside the device in a suited battery charger. Please pay attention to the manufacturer instructions! Used batteries can be returned to us or have to be disposed professionally.

## Grounding

The device has to be grounded properly to measure the amount and the polarity of an electrostatic field. For that purpose the device has to be connected to ground by using the grounding jack (4). Grounding the device by a grounded person (e.g. over conductive shoes or wrist strap) touching the grounding jack suffices under most circumstances.

## Maintenance

The modulator system or parts of it must not be touched. Those parts have to be protected of dust, isolating impurity layers, color- or paint haze and condensate.

If required the modulator system can be cleaned with ethyl alcohol and a lint-free cotton cloth.

## Battery Replacement

When „Low Battery“ appears in the display the 9V battery has to be charged (accumulator) or renewed (alkaline). For this the device has to be turned and the battery case has to be opened by sliding down. The battery has to be taken out and the battery clip pulled off. The clip needs to be plugged to the new battery and put back with the battery into the device. Finally the battery case should be closed again.

## Zero Point

Under normal circumstances a zero point adjustment is not necessary. If the device does not show U=000V while the modulator system is screened (e.g. mounted cover cap) the zero point can be adjusted using the trimmer (6) on the right side of the device. The last digit of the display may be ignored as that error is smaller than the admissible tolerance.

## Guarantee Items

We provide a 24 month guarantee in case of proper application according to the manual. Excluded of the guarantee are: The battery resp. the accumulator, damage by electric shock, wrong grounding and mechanical damage of the device. The guarantee expires if the device was opened.

## Batteries and accumulators are not allowed in the household waste!

Every consumer must by law, dispose of all batteries and accumulators at a municipal or commercial collection center, free of charge. Thereby, the disposal will be environmentally friendly.

Batteries and accumulators are marked with the following symbol:



This crossed out garbage bin means that you may not dispose of batteries and accumulators in the household waste. Under this sign you may also find sometimes, in addition, the following abbreviations related to the materials contents:  
Pb = lead, Cd = cadmium and Hg = mercury.

## Electrical and electronic equipment are not allowed in the household waste!

When the equipment is not used anymore, every consumer must by law, separate the equipment from the household waste and bring it to a municipal collection center. Old electrical equipment is accepted there free of charge. This will ensure that the old equipment is handled by experts and it will avoid negative impact on the environment. Electrical equipment is marked with the following symbol:



The black bar under the crossed out garbage bin indicates that the equipment was put into circulation after August 13, 2005.

## Walking Test



### Product Instruction

With the walking test set (BGT 023) you get together with the EFM 023 a walking tester according to the standard DIN EN 61340-5-1 and EOS/ESD S.3.1.

With the voltage measuring head MK 023 you get a high impedance volt meter with an impedance off  $>10^{16}$  Ohm. That takes to measure static voltage at isolated conductive parts up to 4kV.

Select distance = 1cm that will show you the right values in the display.

**Attention:** The max. measuring voltage value is 4 kV !

Please have a look to the common security advice to handle high voltage and the security advices in this manual.

## Caption

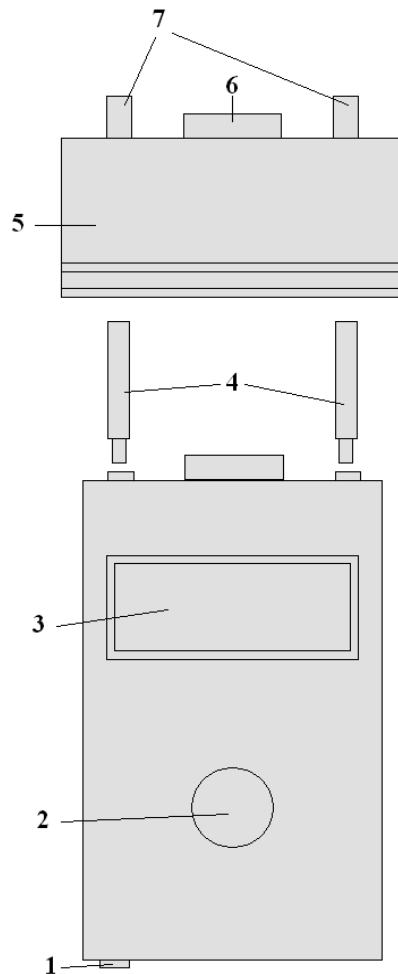

- |   |                          |   |               |
|---|--------------------------|---|---------------|
| 1 | Grounding jack           | 6 | Measure Input |
| 2 | Button «function/on»     | 7 | rim screw     |
| 3 | Alphanumeric LCD display |   |               |
| 4 | Metal spacers            |   |               |
| 5 | Measuring head MK023     |   |               |

## Specifications

## Voltage measuring head

<b>Dimensions (L x W x H):</b>	Approx. 80mm x 40mm x 37mm
<b>Weight:</b>	Approx. 80g
<b>Measuring voltage:</b>	Approx. 4kV

## Hand electrode

<b>Dimensions (L x diameter):</b>	Approx.. 75mm x d25mm
<b>Weight:</b>	Approx.. 100gr
<b>Surface :</b>	nickel-plated

## Operating instructions

### Preparation of the instrument

To make the instrument usable for walking test you have to do :

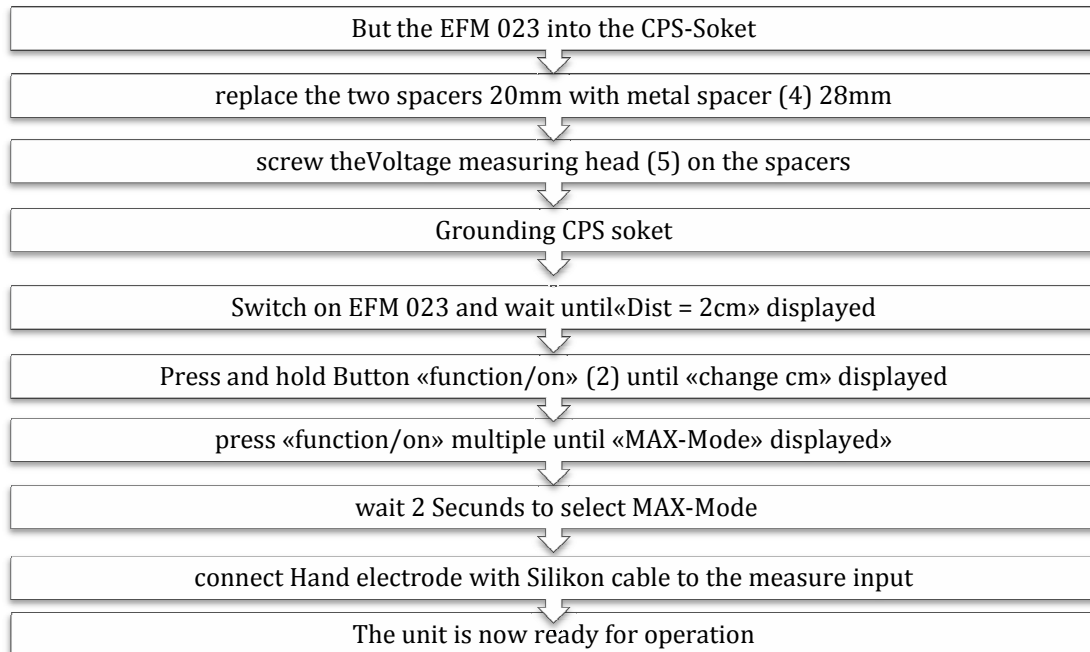

### Measuring process

For measuring the maximum values following those steps:

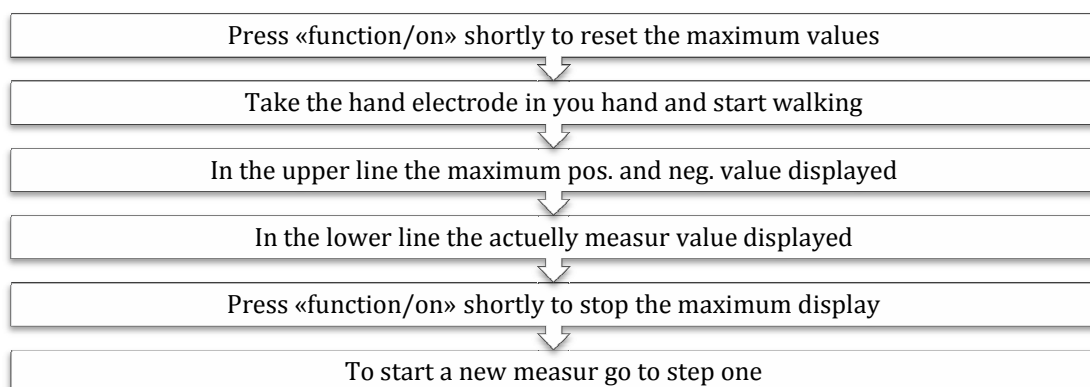

## Walking test with UAC 110 on a PC :

Prepare EFM 023 as description before, but select => «E-Field-Mode» instead of «MAX-Mode»

### The displayed ranges correlatively now :

±20kV/m	→ ±200V
±200kV/m	→ ± 2kV
±1MV/m	→ ± 10kV

**Attention !!** The max. measuring voltage value is 4kV.

Connect UAC 110 into a free USB – interface on your PC and wait until the driver is installed  
Start the „KL\_ReadOut” Software.

By Device => EFM 023 => Voltmeter(MK22) => Range select the same range as selected at the EFM 023.

Select with View => Chart or => Display

Start the walking test by pressing the Start button in the software. End the walking test by pressing Stop button.

By pressing the Reset button max. Values will be erased.

## Scope of Delivery

The basic equipment of the electrostatic field meter includes the following components:

- ESD transport case with conductive foam interior
- Electrostatic field meter
- 2× 9V NiMH accumulators
- Plug-in charger EC109
- Grounding spiral cable with alligator clip
- conductive CPS socket
- Measuring head MK 023
- Hand electrode d20mm x 100mm
- Silicon cable 3m
- Analog Converter UAC 110
- Connecting cable BNC
- USB Y-cable
- KL\_ReadOut Software
- Manual
- Certificate of calibration

## Calibration

A check of the measurement values is recommended annually.

## Warning Notices

- The electrostatic field meter must not be opened. By opening the guarantee expires.
- The electrostatic field meter must not be used in explosive areas. No admission for explosive areas!
- If high charges are possible the electrostatic field meter must be grounded. An adequate distance must be kept.
- Flashovers on the modulator system must be avoided!
- The use of the device in power plants or comparable areas is prohibited!
- The device can not measure alternating fields > 1Hz!

## Ad-On facilities :

### Audit Kit 1 - CPM

*Order code: EFM 023 AKC*

The Das Audit Kit 1 includes additional to the walking test the complete Charge Plate Set CPM 023 all together in a stabile aluminium Case.



### Additional Scope of Delivery

- Plate Electrode 75mm x 150mm (20pF)
- HV - Converter  $\pm > 1.100V$
- Grounding cable 1m
- Aluminium Case instead of the ESD Plastic Case
- Manual CPS

## Audit Kit 2 - Complete

Order Code: EFM 023 AKK

The Audit Kit 2 includes additional to the Audit Kit 1 also our Low Cost TERA – Ohm Meter TOM 100 with Temperature and humidity Sensor TF 100

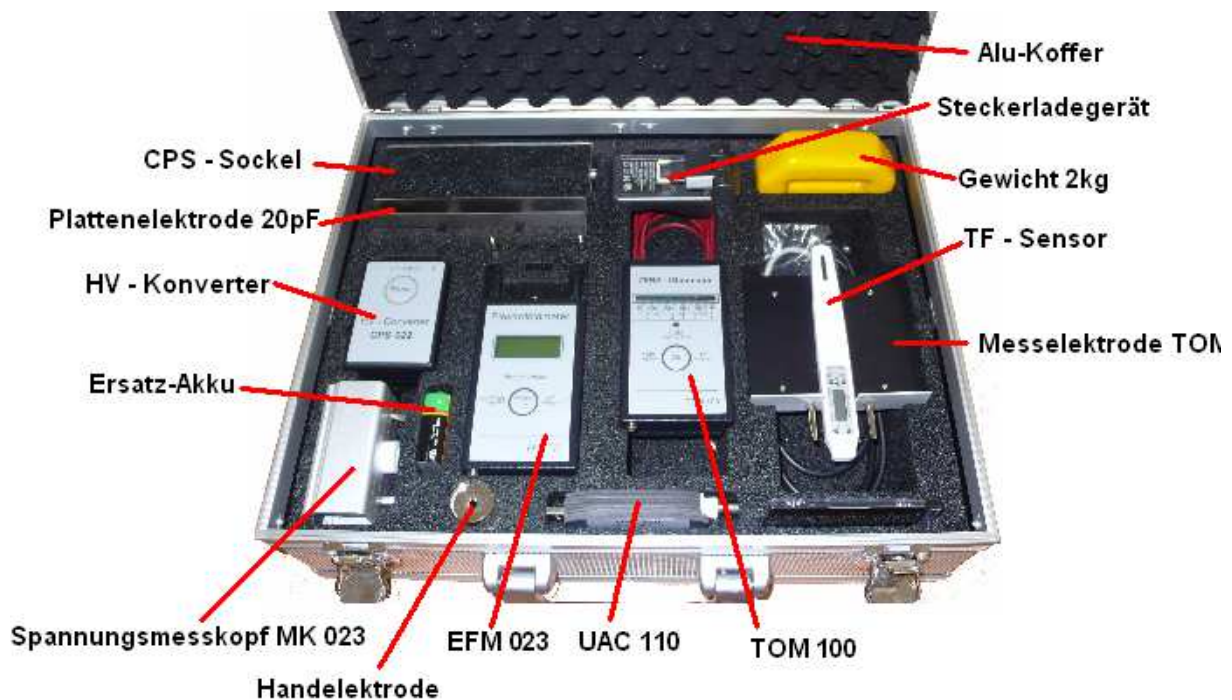

### Additional Scope of Delivery

- Plate Electrode 75mm x 150mm (20pF)
- HV – Converter  $\pm > 1.100V$
- LC – TERA – Ohm Meter TOM 100
- TOM Surface Measure Electrode
- Weight 2kg
- TF – Sensor TF 100
- Aluminium Case instead of the ESD Plastic Case
- Manual TOM 100