

MARSURF | MARSURF LD 130 / MARSURF LD 260



COMBINED CONTOUR AND ROUGHNESS MEASUREMENTS

|  
- 0 +

**Mahr**

EXACTLY

MarSurf LD 130/LD 260. The step into a new dimension.  
**THE UNIVERSAL CONTOUR AND SURFACE MEASURING  
SYSTEM AS A COMPACT MEASURING STATION**



▶ | Combined contour and roughness measurements "in one stroke" can be excellently solved with proven top metrology from Mahr. The measuring stations MarSurf LD 130 and LD 260 are characterized by the consistent further development and integration of experience from the first generation. Excellent metrological features, high measuring and positioning speeds and innovative probe system technology are only a few of the excellent advantages of this measuring system.

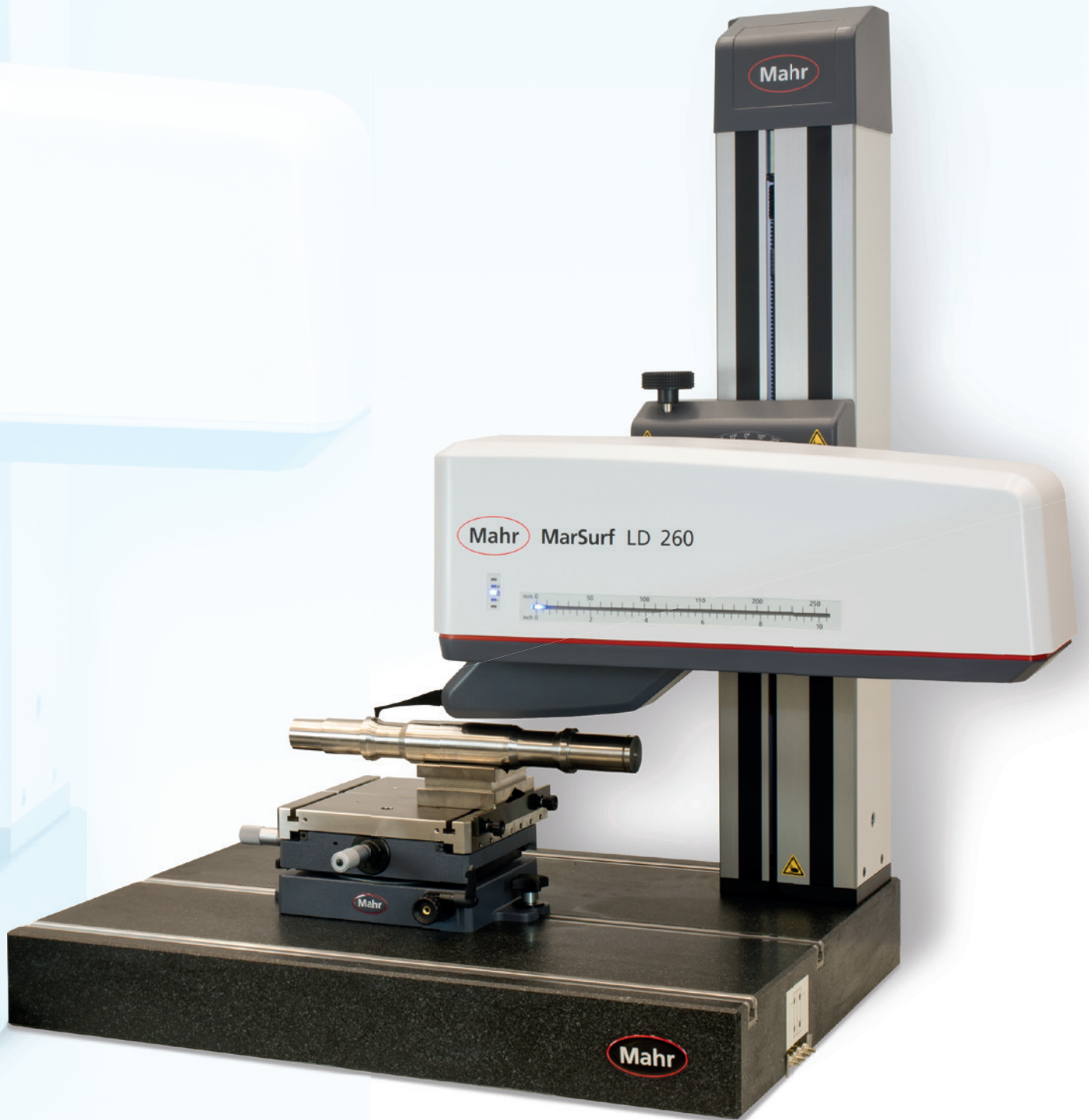

## MarSurf LD 130/LD 260. The Step Into a New Dimension.

**High measuring and positioning speeds**

**Long measuring paths, large measuring stroke**

**Innovative probe system with bionic probe arm design**

**Probe arms with magnetic holder and probe arm recognition**

**Service-friendly due to modular design**

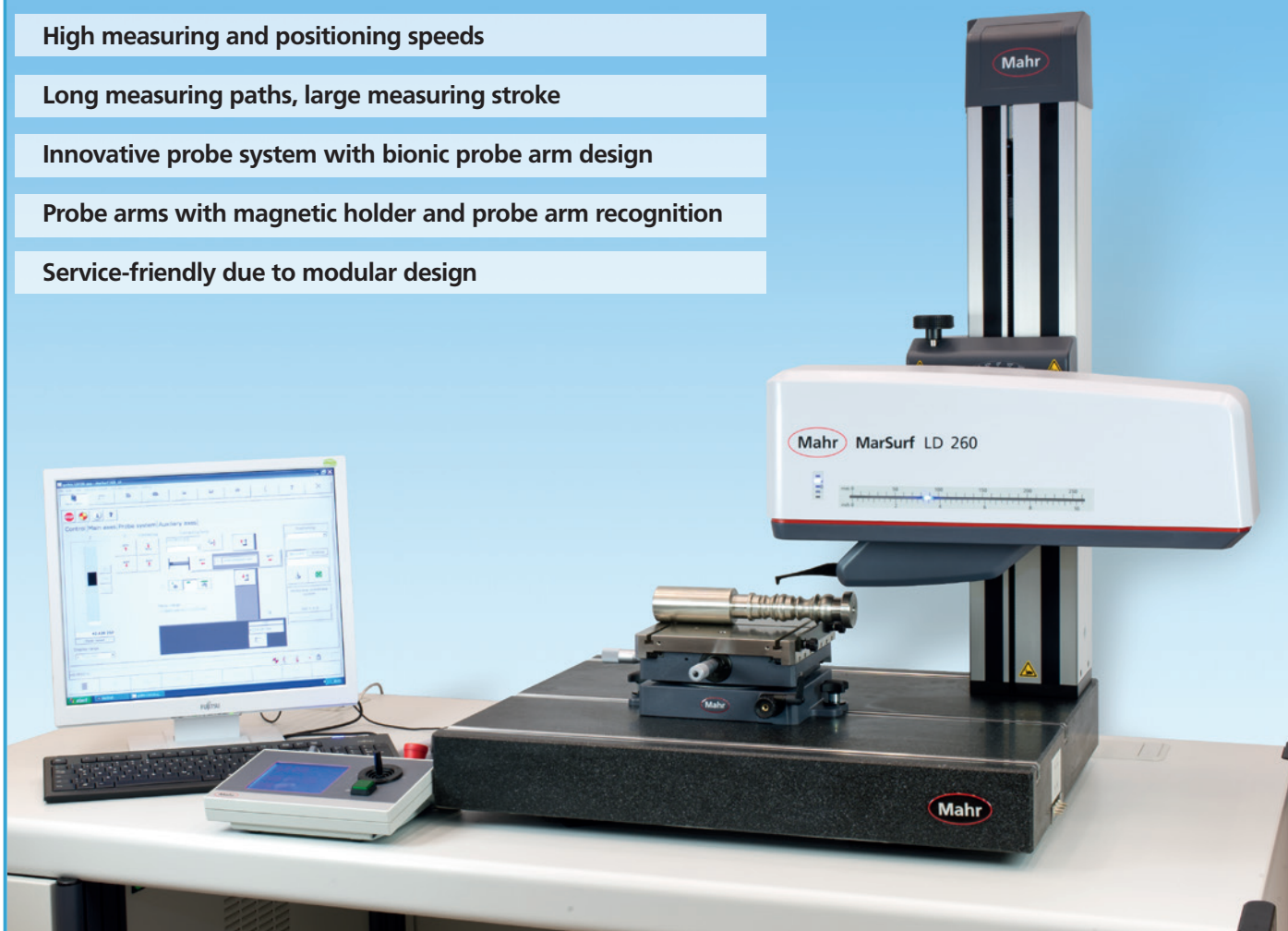

Measuring tasks for different applications increasingly demand the combination of contour and roughness measurements. To meet this need, the unit must deliver a high level of metrological performance. Resolutions in the sub nanometer range as well as residual noise of < 20 nm Rz are just some of the requirements.

With the measuring units MarSurf LD 130 and LD 260 the successful product line of the combined roughness depths and contour metrology MarSurf LD 120 from Mahr is set forth.

The proven and success-bringing benefits of MarSurf LD 120 such as e.g. probe arm holder, automatic probe arm changing device, dynamic measuring force regulation between 0.5 mN to 30 mN as well as the market leading software platform MarWin for all products were maintained.

In addition, the MarSurf LD 130/LD 260 is characterized by important expansion that bring enormous potential for improvement in the measuring room, production and in automatic CNC-measuring procedures.

### **Roughness and contour in one stroke**

Essential features of MarSurf LD 130/LD 260

### **High measuring and positioning speeds considerably minimize the measuring times**

Positioning speed up to 200 mm/s

Measuring speed up to 10 mm/s

### **Innovative probe system solution**

Bionic probe arm design and new material provide great rigidity, lower vibration behavior, higher dynamic.

### **Faster and reliable probe arm exchange with simultaneous probe arm recognition**

with magnetic holder and reliable recognition due to chip located in the probe arm

### **Long measuring paths up to 260 mm (MarSurf LD 260) with a measuring stroke of 13 mm (for 100 mm probe arm length) or 26 mm (for 200 mm probe arm length)**

### **Servicefriendly due to modular design**

Maintenance without complete disassembly of measuring stand possible

## MarSurf LD 130/LD 260. Probe System Operation Principle

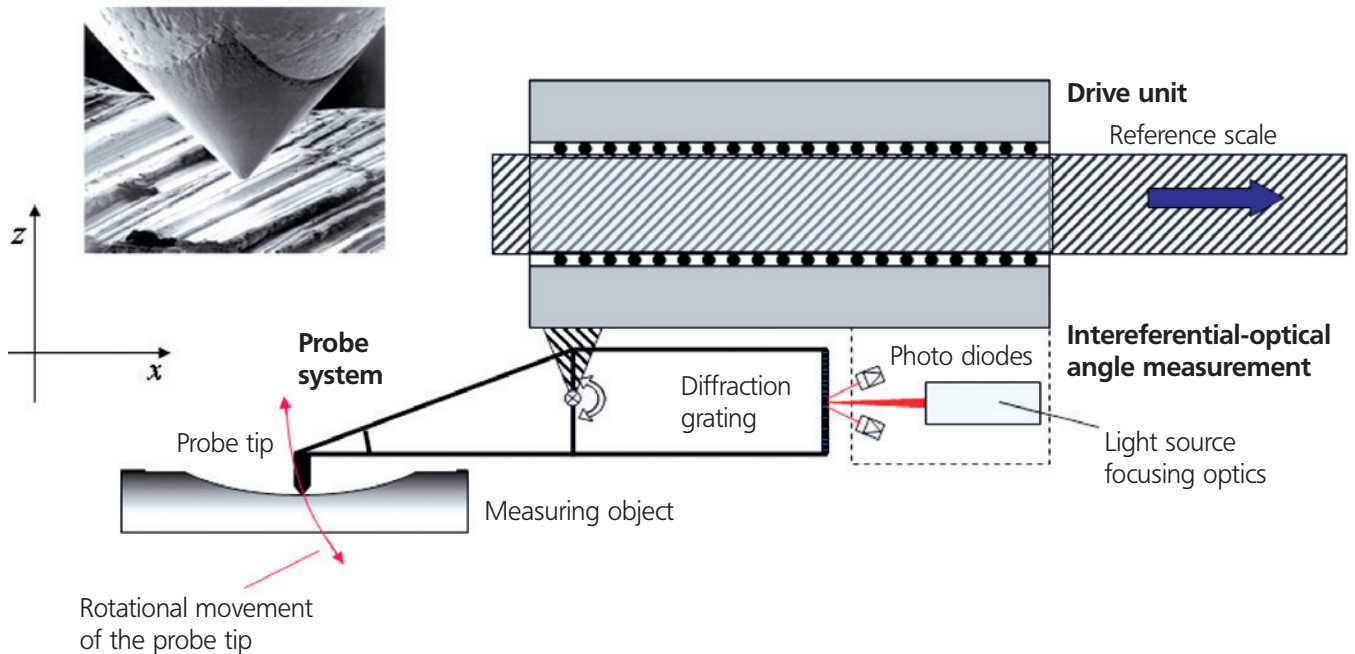

### Probe system – operating principle

The probe principle is based on a rocker arrangement in which the probe tip is located on the one side of the swivel axis and a diffraction grating on the other. The light from a diode is focused on a diffraction grating, forming an interference pattern. The upward and downward movement of the grating leads to changes in the interference pattern on the receiving side, which is registered by photodiodes. A downstream electronics can determine the position of the grating and thus the position of the probe tip.

A moving coil motor is used for the probe positioning in Z direction and the regulated application of the contact force.

For the most common applications, the two probe arms LP D 14-10-2/60° and LP D 14-10-500 belong to the standard scope of the MarSurf LD 130 and LD 260 systems. The bionic construction of the probe arms guarantee high validity and is thus an ideal basis for high accuracy and reliability.

Different probe arms and stylus tip geometries are available for different measuring tasks.

Depending upon the measuring task, diamond tips with 2  $\mu\text{m}$  radius for roughness measurements, carbide tips with 25  $\mu\text{m}$  radius for contour measurements or ruby ball for contour measurements can be used.

With the suitable selection, short- and long-wave profile elements can be recorded and evaluated.



## MarSurf LD 130/LD 260.

### Measuring with MarSurf LD 130/LD 260

The easy, fast and reliable way – from the workpiece to the measurement to the result:

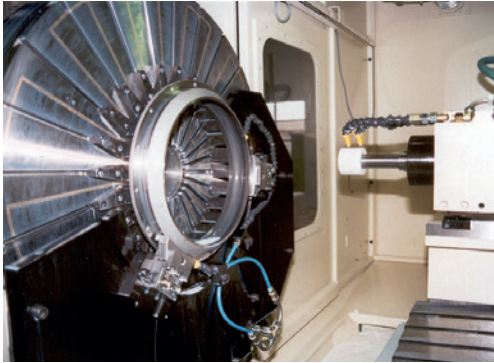

Processing machine

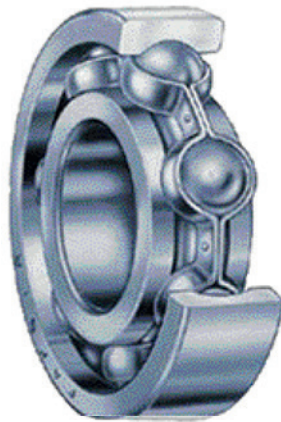
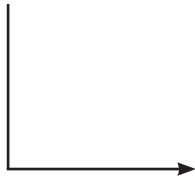

Workpiece

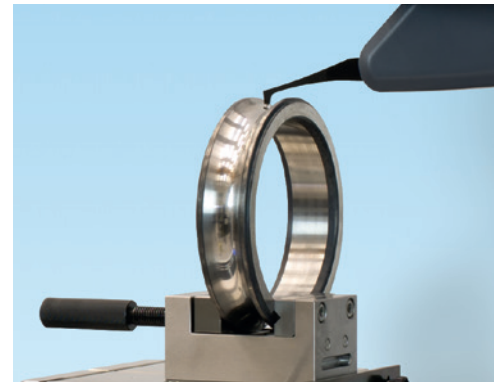
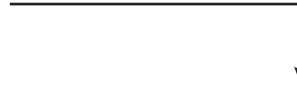

Measurement

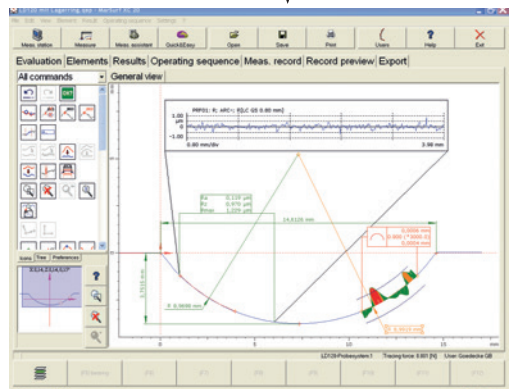
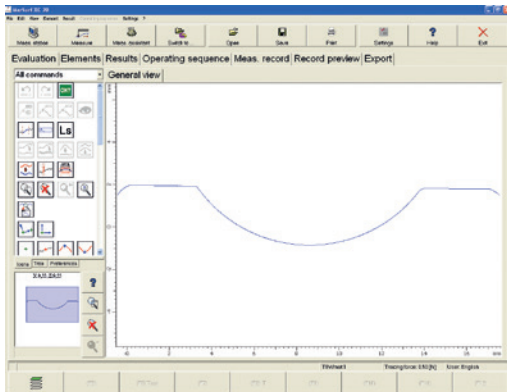

Result

## MarSurf LD 130/LD 260. Measuring Range.

### New standards for measuring volume, dynamics, speed and flexibility

#### Large measuring range with MarSurf LD 130/LD 260

The dimensions in this generation of devices are particularly excellent.

With MarSurf LD 260 measuring paths up to 260 mm in X direction (horizontal) and 26 mm (200 mm probe arm) in Z direction can be travelled.

Applications such as racks, thread spindles and ball spindle can now be fully measured in this dimension.

Straightness measurements on large workpieces as well as testing of guides are possible.

#### Measuring ranges

##### MarSurf LD 130



##### MarSurf LD 260



■ 100 mm probe arm    ■ 200 mm probe arm

#### Expansion of the measuring range with measuring stand ST 750 D

In combination with the measuring stand ST 750 D, the vertical measuring and working range can be expanded up to 620 mm.

By offsetting the travel path of the measuring stand car, diameters or vertical distances, for example, can be measured.

A typical application is e.g. the diameter measurement of large bearings.

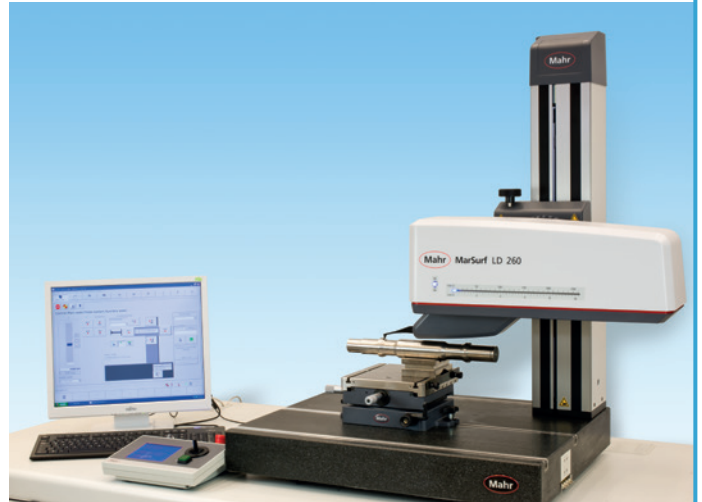

Shaft measurement with MarSurf LD 260

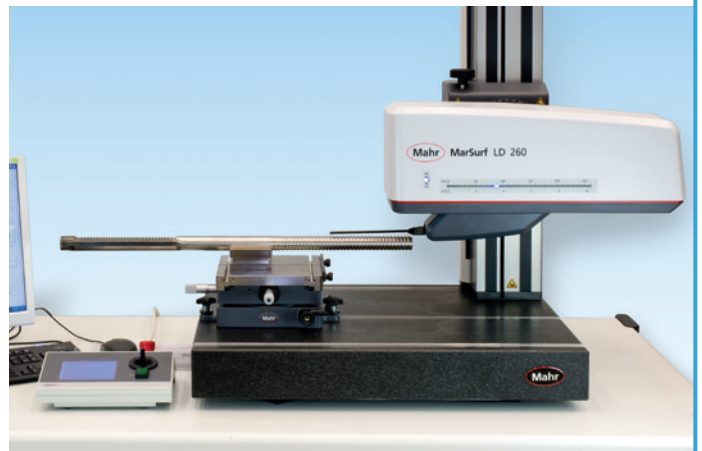

Rack measurement with MarSurf LD 260

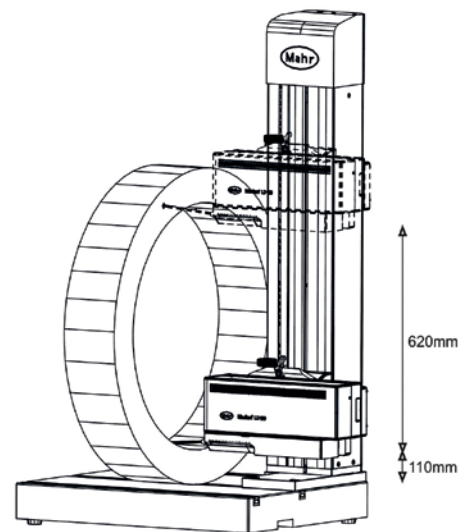

Depiction of workpiece edge

## MarSurf LD 130/LD 260. Speed

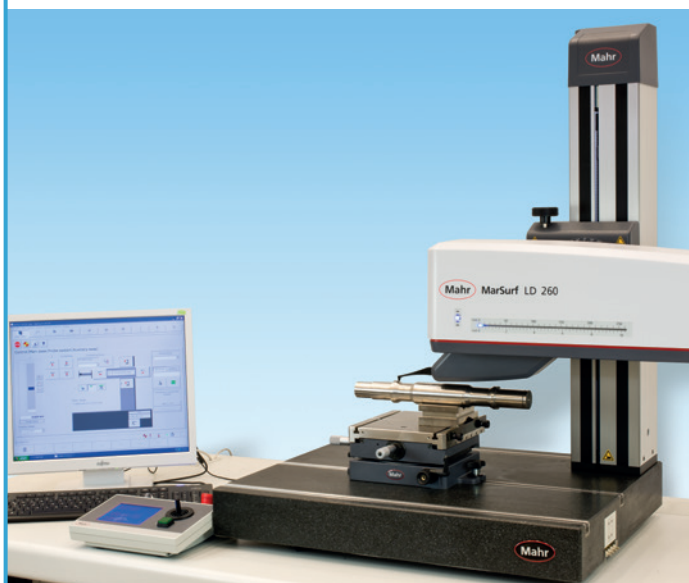

New standards for measuring volume, dynamics, speed and flexibility.

**High measuring and positioning speeds enable enormous time-savings**

Positioning speed up to 200 mm/s  
Measuring speed up to 10 mm/s \*

\* For roughness depth measurements, maximum speeds of up to 2 mm/s are possible, depending upon measuring task

**Example of roughness depth measurement on a shaft at measuring points A and B**

**Shaft length ca. 260 mm**

**Measuring paths each 5.6 mm at measuring points A+B**

Total time for measuring task	
previously	approx. 60 s.
now	approx. 30 s

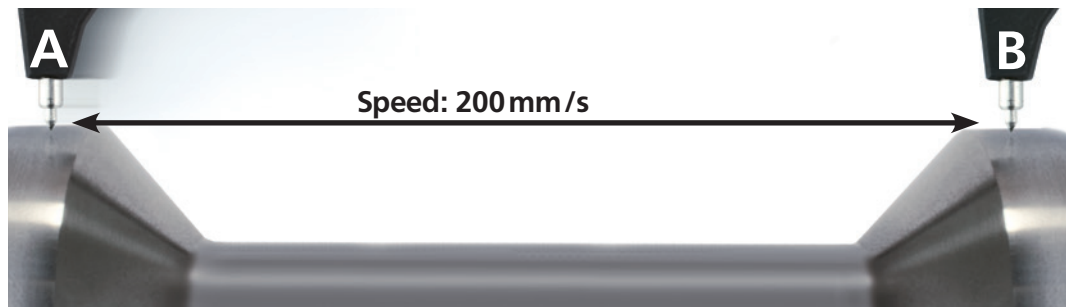

## MarSurf LD 130/LD 260. Flexibility



**Flexibility due to:**

- Tilting the drive unit  $\pm 45^\circ$  on the measuring stand

**Measurement "above and below"**

- Use of double probe tips with measuring force switching for measuring "above and below" on contour and roughness depth profiles.

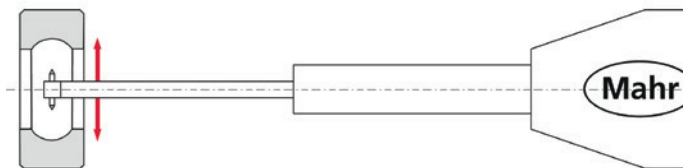



## MarSurf LD 130/LD 260. Innovation Dynamics

### X drive with highest dynamics

- Minimum speed: 0.02 mm/s
- Maximum speed: 200 mm/s
- **Max/Min = 10,000!**

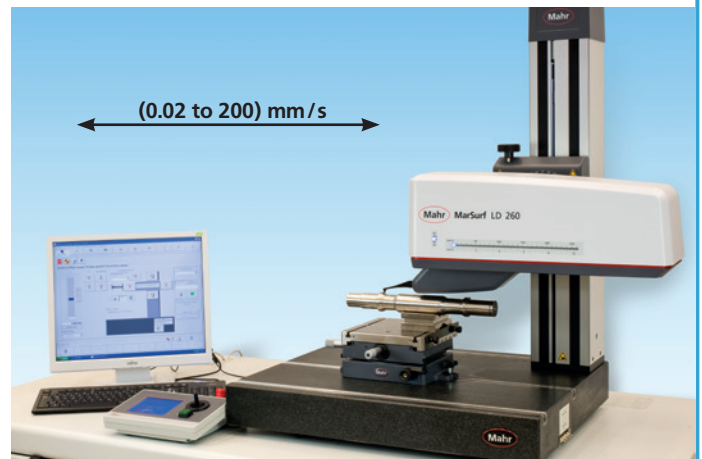

Measurement of a shaft with MarSurf LD 260

### Example passenger car

- V max = 250 km/h
- V min = 5 km/h
- **Max/Min = 50!**

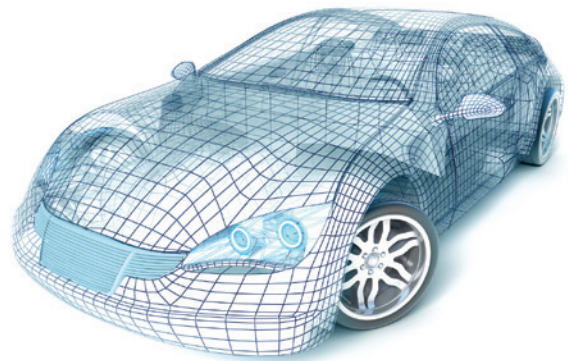

## MarSurf LD 130/LD 260. Service and Safety Concept

Reliability due to an innovative design and service-friendly concept.

### Service concept

- Service components for field service.
  - Probe system
  - Powertrain
  - Electronics
  - Housing
- When replacing these components, the new alignment of the CNC measuring stations is not necessary!

### Integrated collision protection

- Lower housing part of the X axis switches in Z direction
- Housing of the probe system switches in X /Y and Z directions
  - Z = Travel direction of the measuring stand
  - X = Travel direction of the drive unit
    - TX axis, other positioning axis
  - Y = Travel direction TY axis
    - other positioning axis, operator

### Your advantages

- Short service times
- Low costs
- No additional cable route
- No loss of measuring volume



## MarSurf LD 130/LD 260. The Probe System



- Probe arm LP D in bionic design
- Improved probe system dynamics = 41% higher measuring speed with same reproducibility
- Rigidity and low tendency towards self-oscillations due to construction principle corresponding to natural structures
- Innovative material selection reduces the move mass by 50 %
- Higher measuring speed due to
  - lower moment of inertia
  - high material damping
- At the same time robust due to stiffer mounting
- Probe arm with integrated chip
  - for recognition and identification of probe arm
  - to control if probe arm is **correctly inserted**
  - probe arm provides its information (probe arm data sheet)
  - advantages over the RFID principle, since switching only takes place when the probe arm has direct contact
- Faster trouble-free probe arm change due to magnetic holder
- Can be used with the probe arm changing unit TWE

## Probe arms

A large selection of probe arms gives you flexibility and guarantees that your measuring tasks can be solved.

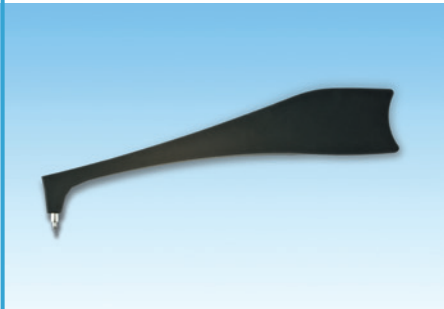

Probe arm LP D 14-10-2/60°  
Order no. 6852601

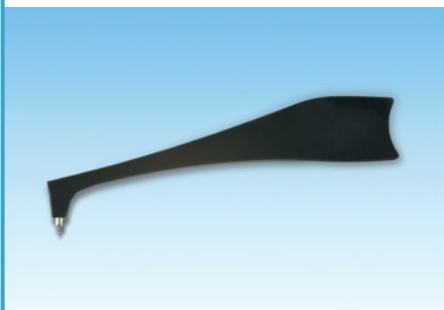
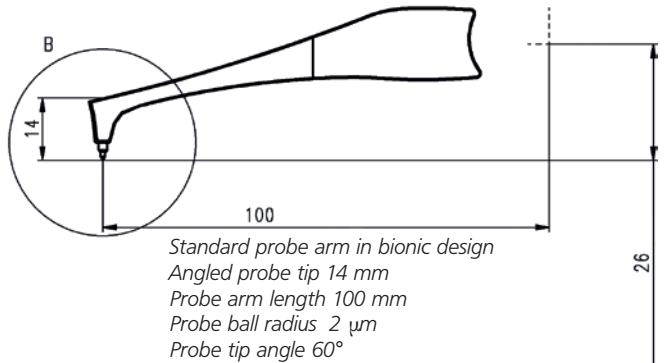
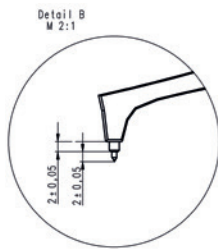

Probe arm LP D 14-10-500  
Order no. 6852600

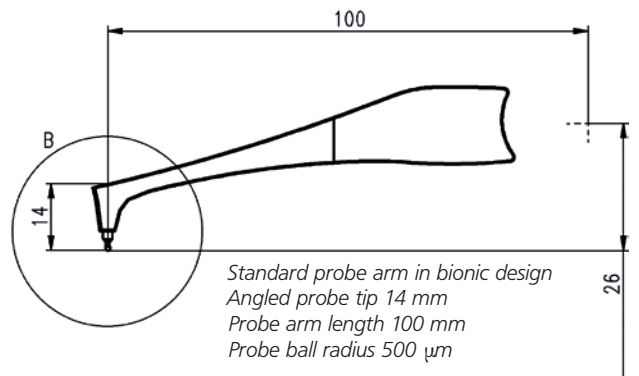
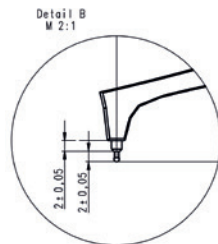

## MarSurf LD 130/LD 260. The Probe System



Probe arm LP C 45-20-5  
Order no. 6852620

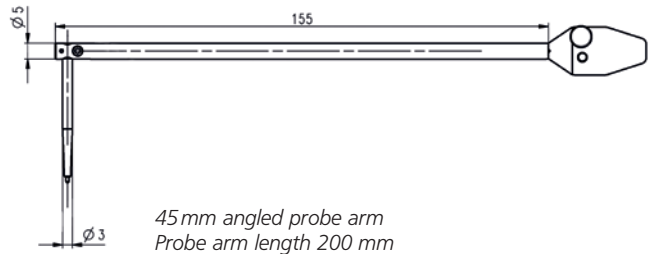
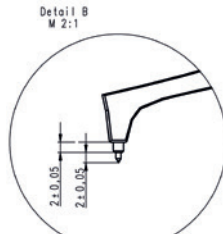

45 mm angled probe arm  
Probe arm length 200 mm  
Probe tip radius 5 μm

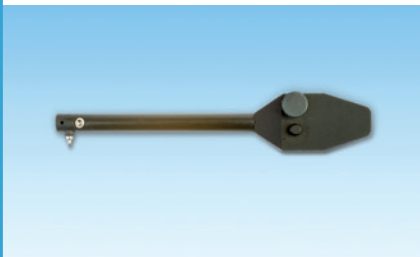

Probe arm LP C 10-10-2/90°  
Order no. 6852617

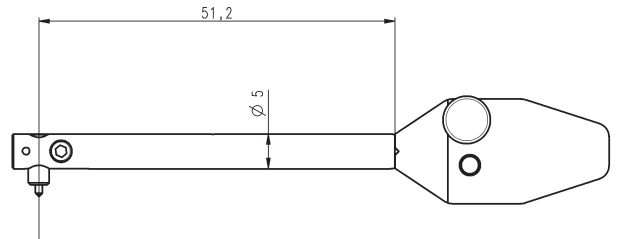
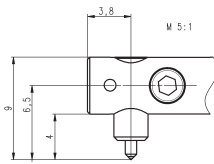

Probe arm for bore from 10 mm  
Probe arm length 100 mm

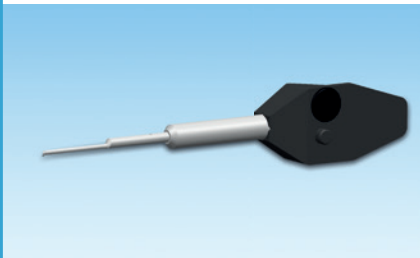

Probe arm LP C 1,3-10-2/60°-s45°  
Order no. 6852606

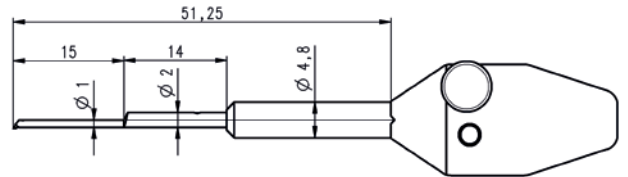
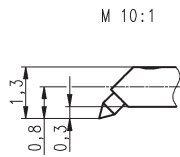

Probe arm with 45° angled probe tip for bores  
from 1.3 mm diameter  
Probe arm length 100 mm

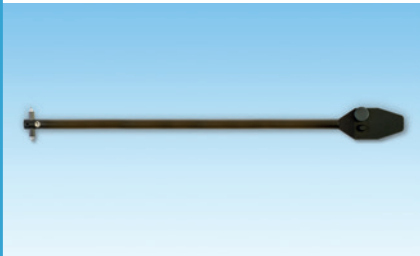

Probe arm LP T 16-20-5/47°  
Order no. 6852623

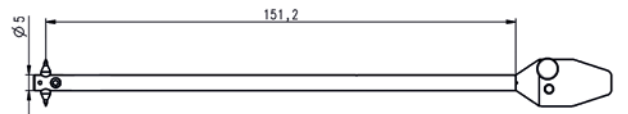
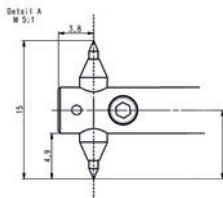

Probe arm with double probe tip  
for bores from 16 mm Ø  
Probe arm length 200 mm  
Probe tip radius 5 μm



Probe arm LP T 16-20-250  
Order no. 6852622

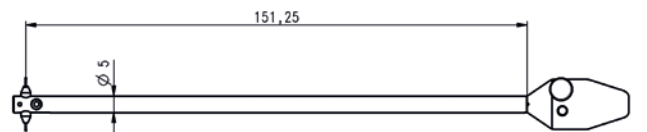
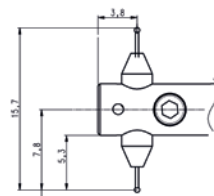

Probe arm with double probe  
tip from 16 mm  
Probe arm length 200 mm  
Probe ball radius 250 μm

## MarSurf LD 130/LD 260. The Step Into a New Dimension



### MarSurf LD 130 with measuring stand ST 500 CNC

MarSurf XCR 20:	6268385
consisting of:	
Midrange LD 120/130/260	
Software MarSurf XCR 20	
Mahr license key	
MarWin PC*	9xxxxxx
TFT monitor 24"	3027221
MCP 21 advanced	7033935
Drive unit LD 130 incl. probe systems and probe arms	6720821
LP D 14-10-2/60°	
LP D 14-10-500	
Calibration standard for Contour 1, Accuracy Class 1	6820121
XY table CT 300	6710549
Measuring Stand MarSurf ST 500 CNC with HG 700mm x 550mm	6710254
Control module HZ	6851376
Damping element set	6851399

\* Position dependant upon country

## MarSurf LD 130/LD 260. Innovation dynamics

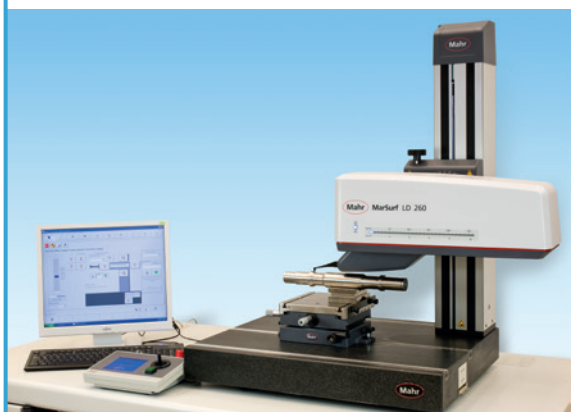

### MarSurf LD 260 with measuring stand ST 750 CNC

MarSurf XCR 20 consisting of:	6268385
Midrange LD	
Software MarSurf XCR 20	
Mahr license key	
MarWin PC*	9xxxxxx
TFT monitor 24"	3027221
MCP 21 advanced	7033935
Drive unit LD 260 incl. probe systems and probe arms	6720826
LP D 14-10-2/60°	
LP D 14-10-500	
Calibration standard for Contour 1, Accuracy Class 1	6820121
XY table CT 300	6710549
Measuring stand MarSurf ST 750 CNC with HG 700mm x 550mm	6710252
Control module HZ	6851376
Damping element set	6851399

\* Position dependant upon country

## MarSurf LD 130/LD 260. Technical Data

The technical data is valid for the standard probe arm LP D 14-10-500 and LP D 14-10-2/60°

### Features of horizontal axis

	MarSurf LD 130	MarSurf LD 260
Tracing length (Lt)	0.1 mm to 130 mm	0. mm to 260 mm
Safety contacts in the motorized procedure to switch off the respective feed motor	front, back	
Positioning speed	0.02 mm/s up to 200 mm/s	0.02 mm/s up to 200 mm/s
Measuring speed	0.02 mm/s up to 10 mm/s; for roughness measurements, 0.1 mm/s bis 0.5 mm/s is recommended	
Profile point distance in X	0.05 µm bis 30 µm, adjustable	
Max. number of measuring points per measurement	2.6 million points	5.2 million points
Resolution in	0.8 nm	
Uncertainty of X axis display	± (0.2+I/1000) µm; I in mm	
Inclination of the measuring stand with ST 500 CNC (HZ+HB) or ST 750 CNC (HZ+HB)	±45°; without active adjustment of the measuring force	

### Probe system features (w)

	Measuring direction Z+ / Z-
Probe measuring range	13 mm (100 mm probe arm) 26 mm (200 mm probe arm)
Resolution	0.8 nm
Measuring force	0.5 mN to 30 mN, can be set by software

### Residual value Rz<sub>0</sub>, Rq<sub>0</sub>

Measuring and evaluation conditions as per DIN EN ISO 3274, Lc = 0.25 mm, Lc/Ls = 100

	MarSurf LD 130	MarSurf LD 260
Residual value when vt = 0.1 mm/s	Rz <sub>0</sub> ≤ 20 nm Rq <sub>0</sub> ≤ 1 nm, typical	

### Contour

All information acc. to VDI/VDE 2629 Sheet 1 – MPE Maximum Permissible Error

Measuring conditions acc. to probe arm data sheet.

Values for distance L and radius R in mm

	MarSurf LD 130	MarSurf LD 260
Display deviation for distance measurement <b>EA</b> (MPE <sub>EA</sub> )	± (1.0+I/150) µm; I in mm	
Display deviation for radius measurement <b>R<sub>K</sub></b> (MPE <sub>R</sub> )	(R ≤ 10 mm) (10 mm < R ≤ 300 mm) (R > 300 mm)	± 1 µm ± 0.17 + (R/12) µm ± (-18 + R/7) µm

### General data

	MarSurf LD 130	MarSurf LD 260
Operating temperature	+15 °C bis +35 °C	
Working temperature to achieve technical data	20 °C ± 2 K	
Recommended measuring room class according to VDI/VDE 2627	2 or better	

## MarSurf LD 130/LD 260. Calibration.

### Calibrating: The basis for accurate results!

An intelligent calibration system enables measurements with  $\mu\text{m}$ -accuracy.

Geometry calibration, deflection and form measurement calibration are essential components.

A simple-to-use measuring program easily and quickly guides the user through the calibration steps. As soon as a probe arm has been calibrated, the data is saved so that when changing probe arms, a new calibration is not necessary.

This standard is also suitable for the calibration of the double-tip probe arm.



Calibration standard Contour 1 for MarSurf LD 130 / LD 260  
Order no. 6820121

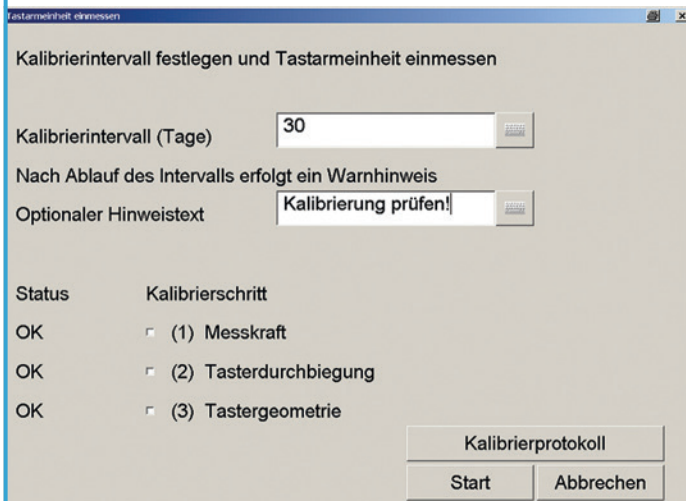

An essential benefit of the probe arm for MarSurf LD 130 / LD 260 is the magnetic holder that enables the probe arm change without the use of tools. Probe arms are quickly and easily changed to suit different measuring tasks.

The calibration menu enables the calibration of every probe arm and the storage of calibration data. Calibration is only necessary once per probe arm. Recalibration is not necessary when changing probe arms.

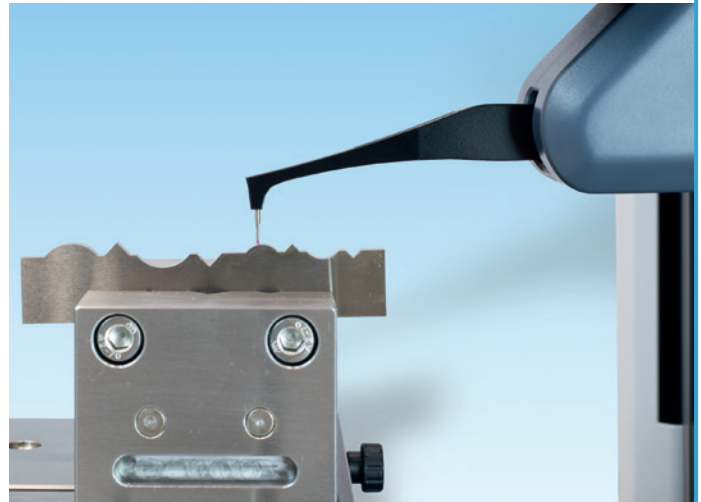

Contour standard KN 100  
Order no. 6820125

The contour standard KN 100 is used for the practical control of the measuring station.

The standard contains the most important geometric elements. Upon request, the KN 100 can be delivered with a DKD / DAkkS- or Mahr certificate.

**DKD / DAkkS calibration for KN 100**  
**Mahr calibration for KN 100**

**Order no. 6980110**  
**Order no. 9964316**

## MarSurf LD 130/LD 260. MarWin Software

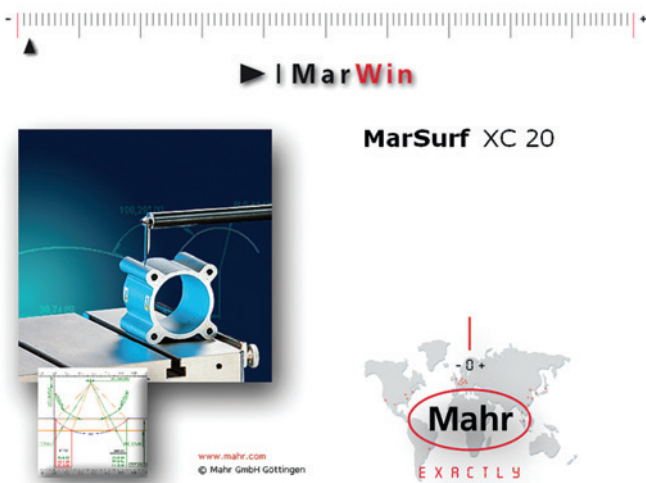

The software platform MarWin gives the user the possibility to use a service that is characterized by ease of operation and various measuring and evaluation criteria. Standardized symbols, clearly structured operation processes even for different applications, an explicit regulation of user rights, are only some of the many features that make it easier for the user.

It is possible to expand with MarWin-based software applications such as MarSurf XT 20 any time. Simple measuring station depictions with the respective axes allow the user to work quickly and reliably.

The travel speed of the axes can be directly selected in touch button operation in 3 speeds.

To facilitate the zenith search, the display area can be set to the optimal magnification.

Operation is made easier with clearly recognizable symbols. Since many operators create measuring procedures according to their own priorities, symbols can be selected as favorites. Help can be activated for the selected symbol at any time.

The setting of the measurement conditions, the positioning of the probe in the "loading position" as well as measuring position and the positioning after the measurement together with all conditions are configured in the "measuring assistant".

Multiple measurements, notes during a measurement procedure and much more are provided in easily manageable operation procedures.

### Top technology even in the software

Years of further development of the contour-roughness depth software and topography software with the possibility to select additional interesting options give the user access to one of the most high performing platforms worldwide.

Thanks to an easily understandable user interface, the steps of the measuring and evaluation procedures can be carried out quickly and in a user-friendly manner.

### Expansion options

- Data export QS STAT
- Thread evaluation
- Profile processing
- Dominant waviness
- Double probe tip measurement
- User-defined parameters
- Parameters as per ISO 13565-3
- Topography

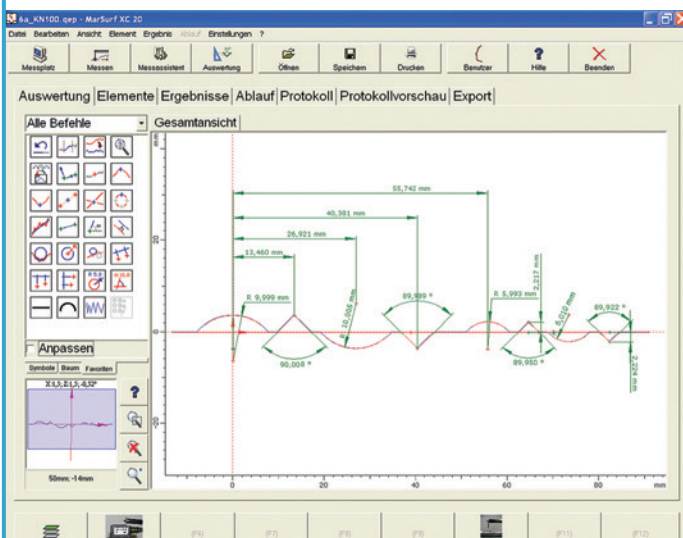
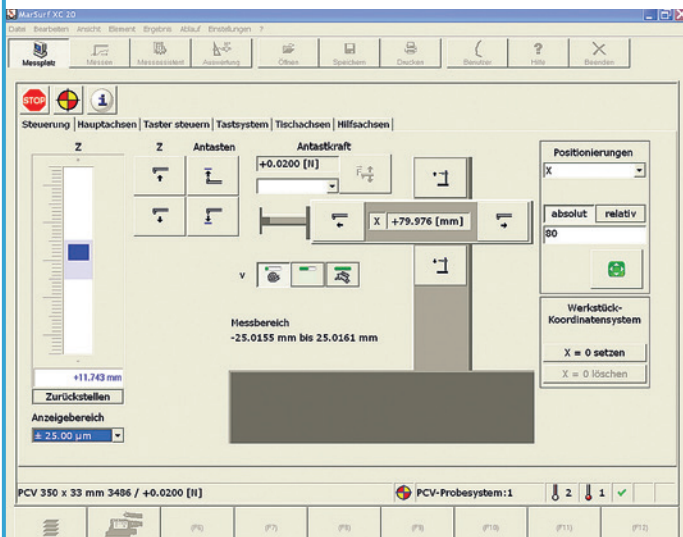

## MarSurf LD 130/LD 260. MarWin Software

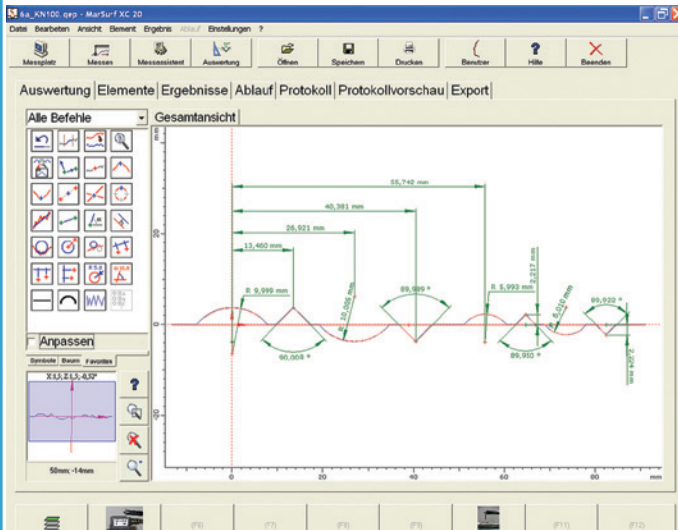

### Standard evaluation

Quick and easy evaluation of geometric basic elements such as, e.g. radii, angles and distances to coordinate axes are made easy as pie with the help of tools from the action box.

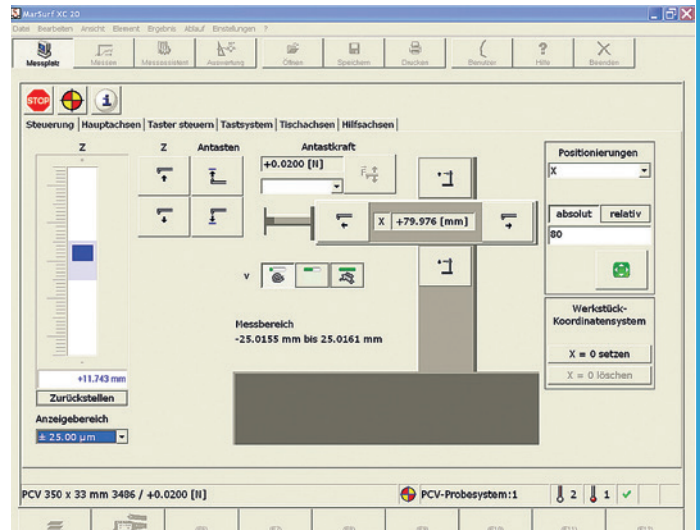

### Line form evaluation

Deviation of the actual geometry to the target geometry are graphically depicted. The pre-selected tolerance band shows on one look if the workpiece is within or without of the tolerance.

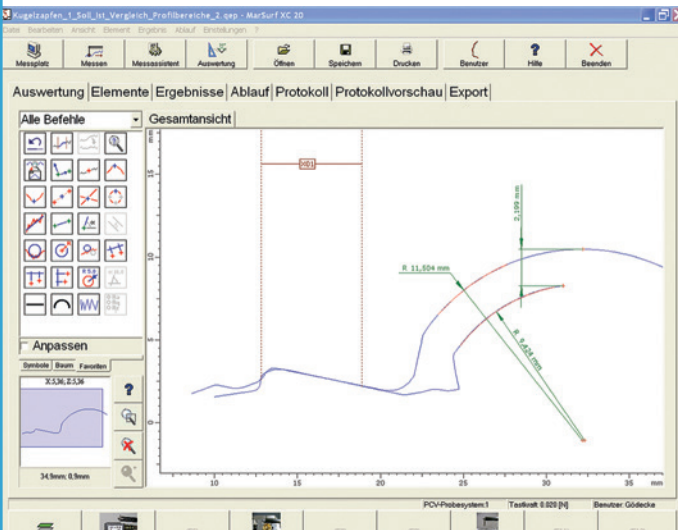

### Target-actual comparison

The comparison of an actual profil with a target profil is one of the most demanding tasks of contour evaluation. In the example shown above, the fitting takes places specifically in the depicted profile. Now the different dimensions can be determined that in this case portray the wear of a workpiece.

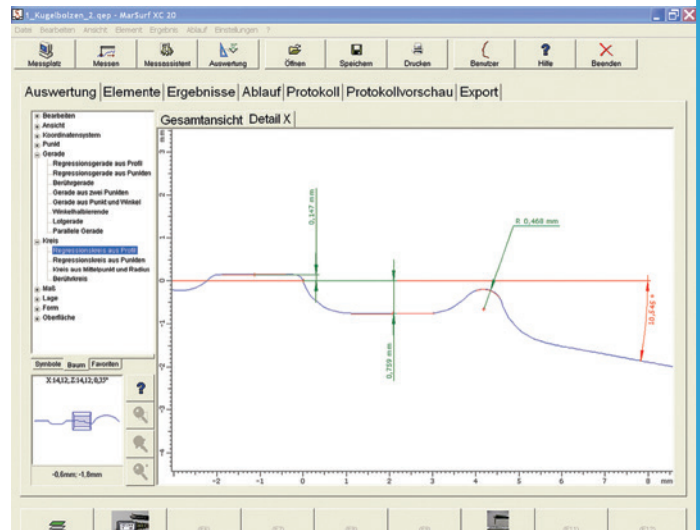

### Formation of help references

Many technical workpiece drawings contain measurements whose references are not depicted in a visible edge but in a help reference. In this example, the formation of a parallel to a workpiece edge is depicted.



## MarSurf LD 130/LD 260. MarWin Software

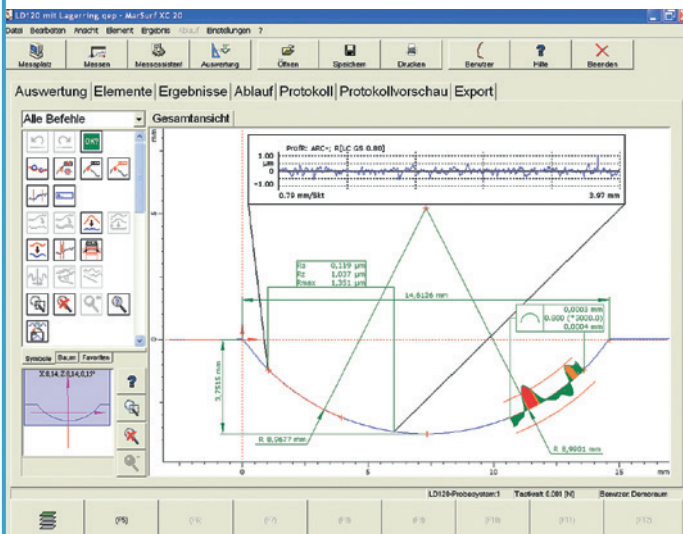

### Evaluation of contour and roughness depth on a bearing with MarSurf XC 20 software.

Combined contour and roughness depth and evaluation. The result evaluation of distances, radii, evaluation of the line form deviation as well as roughnessdepth evaluation of a selected profile segment.

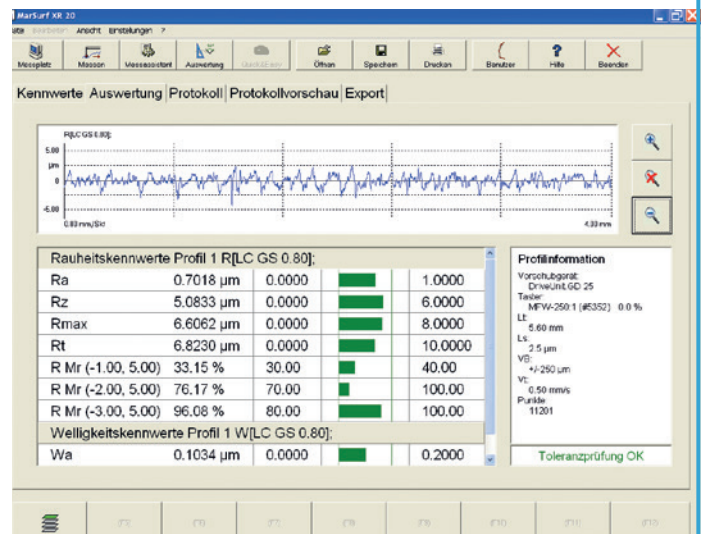

### Evaluation of roughness with tolerance monitoring with software XCR 20

Evaluation of diverse roughness parameters such as Ra, Rz, Rmax, Rt, material ratio as well as waviness parameter Wa, with tolerance monitoring and statistics through multiple measurements.

## Software data export QE QS-STAT

### Export as per AQDEF: Mahr has AQDEF certification Version 3.01 Category B

The quality of data export is confirmed by this certificate.

#### Your advantage:

With the option QE QS-STAT Plus you implement an application that has the most current status of AQDEF certification. Adaptation work is greatly reduced.

For users of the statistics software from Q-DAS, Mahr offers with its PC-based products from the surface and form measuring station program with the options **QE QS-STAT** and **QE QS-STAT Plus** easy and convenient data export that is suited to all of your individual needs with

#### QE QS-STAT

With this option, **all features** can be exported according to the rules of the Q-DAS handbook. For many applications, this option provides the easy and fast way to export data.

With the information from measured features and measuring record head data, **QE QS-STAT** can create valid export data without having to make any adaptations. There are many K-fields ("keys") that can automatically be filled with the corresponding information from the features or the environmental data (e.g.

information from the measuring record heads, number of features,...).



## MarSurf LD 130/LD 260. Mechanical Engineering Industry

### Applications in mechanical engineering

- Ball screws
- Threads, thread pins
- Shafts
- Guideways
- Joint elements
- Pump components
- Compressor components
- Ball heads
- Tool stamps
- Moulding components
- Hydraulic parts
- Pneumatic parts
- Valves
- Racks

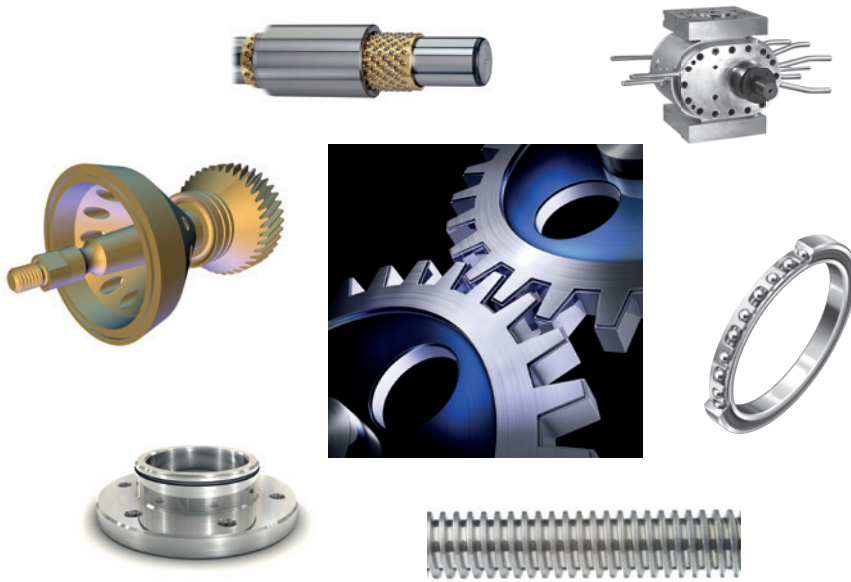

### Measuring task: Measurement of the inner ring of a ball bearing

- Evaluation of geometric data
- Determination of radius
- Determination of middle point of Gothic profile
- Determination of line form deviation
- Evaluation of roughness depth parameter

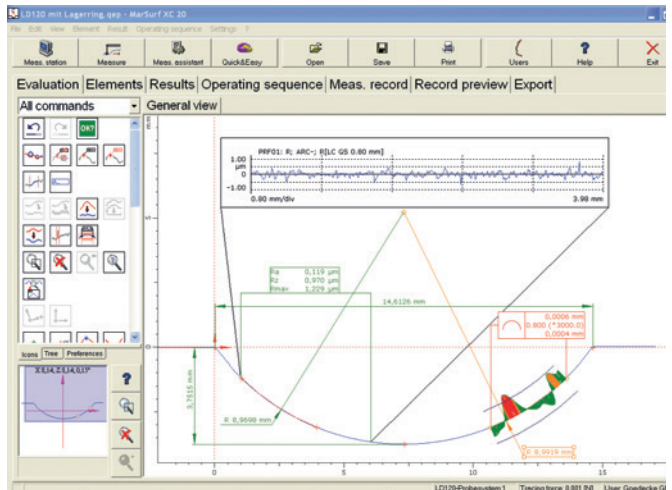
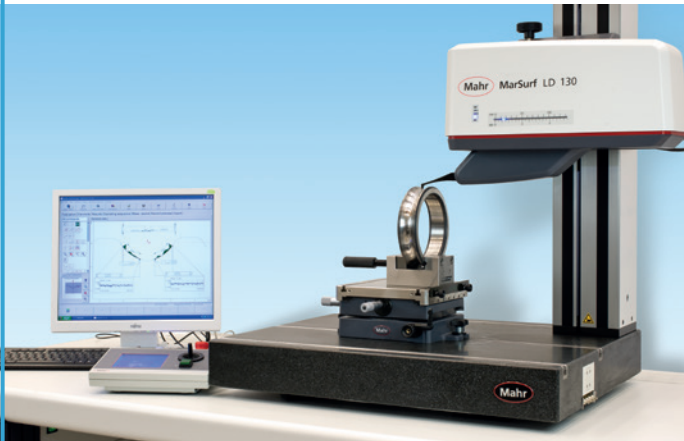

## MarSurf LD 130/LD 260. Production Engineering Industry

### Application CNC metrology

- Contour and roughness depth measurement in semi-automatic to fully automatic process.
- Expansion of standard measuring station with
  - additional axes
  - mount specially suited to the workpiece
  - measuring cabins
  - fully automatic probe arm change
- Special software MarWin CNCplus
- Safety concept



### Measuring task: Pump body

- 5-axis measuring station for the measurement of roughness and contour in automatic operation
- Measurement on more than one hundred measuring points
- Automatic probe arm change with probe arm changing unit TWE
- Measuring cabin with vibration dampened table
- Lamp signal to indicate status of the measuring results
- Software MarWin CNCplus

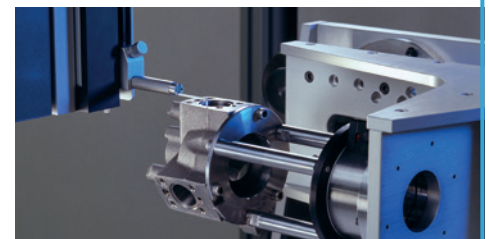
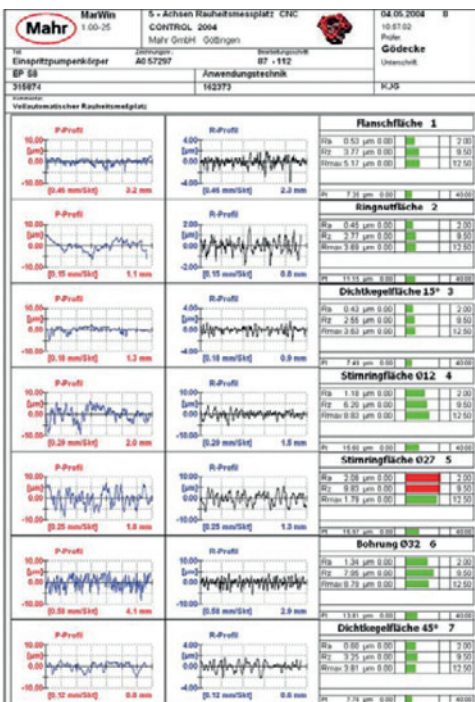

## MarSurf LD 130/LD 260. Automotive Industry

### Applications in automotive engineering

- Motor parts
  - Cylinder block
  - Cylinder head
  - Crank shaft
  - Conrod
  - Pistons
  - Camshafts
  - Piston rings
  - Valves
- Steering
- Gears
- Injection system
- Turbocharger
- Body



### Measuring task: Rack measurement (steering)

- Evaluation of the geometric data of the "Gothic Profile"
- Determination of line form deviation
- Measurement of roughness depth of "Gothic profile"
- Measurement of tooth profile
- Determination of roughness depth of tooth profile
- Determination of pitch
- Ball circle diameter with double tip probe

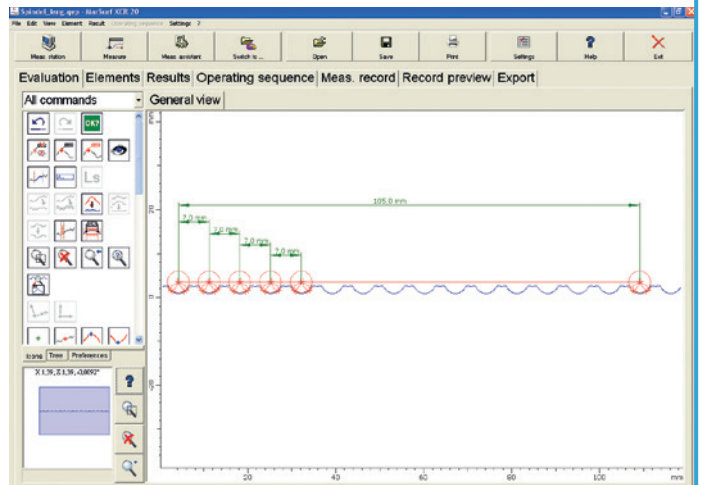
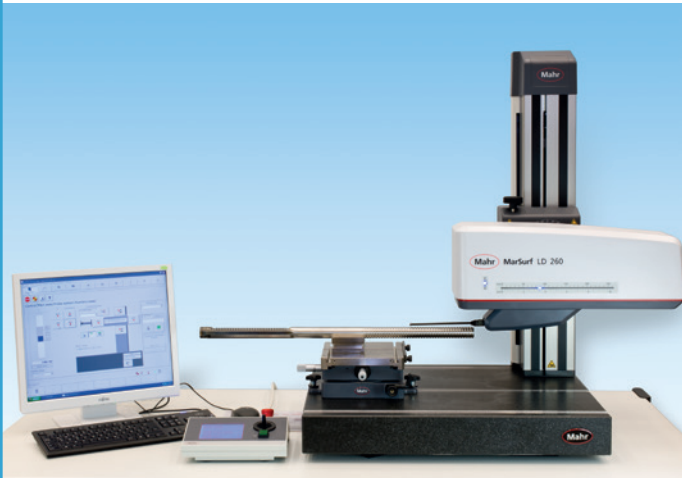

## MarSurf LD 130/LD 260. Optics Industry

### Applications in optics

- Contour and roughness depth measurement of the aspheric lens
- Contour and roughness depth measurement of the frame
- Contour and roughness depth measurement of the cylinder lenses
- Contour and roughness depth measurement of the housing components

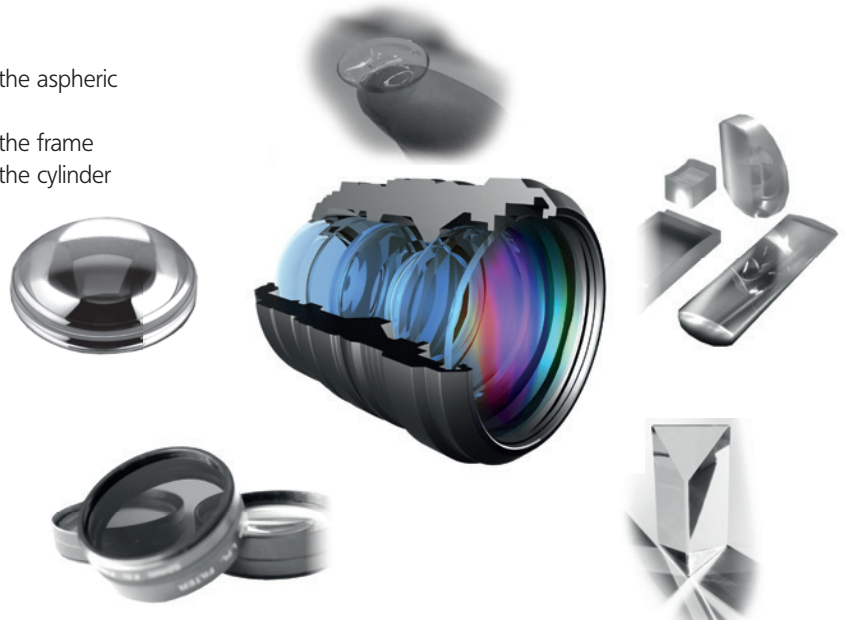

### Measuring task: Asphere – Evaluation of the surface accuracy error

- Measurement data acquisition of the aspheric contour
- Target - actual comparison of the measured contour with the ideal contour
- Output of parameters PV, RMS and slope error
- Provision of the differential profile for use in the processing machine (closed-loop)

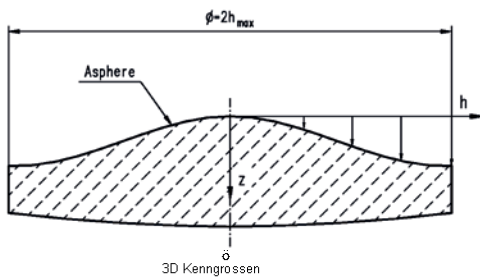

X-Profile

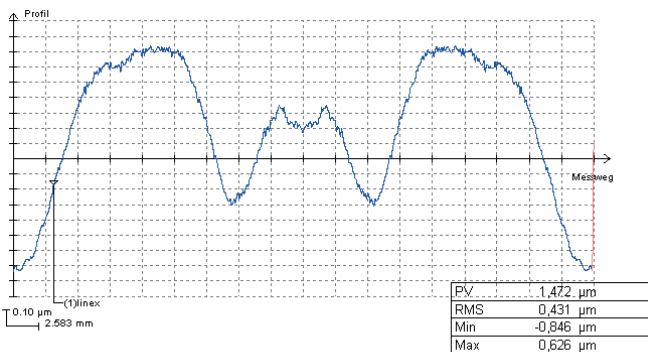

Y-Profile

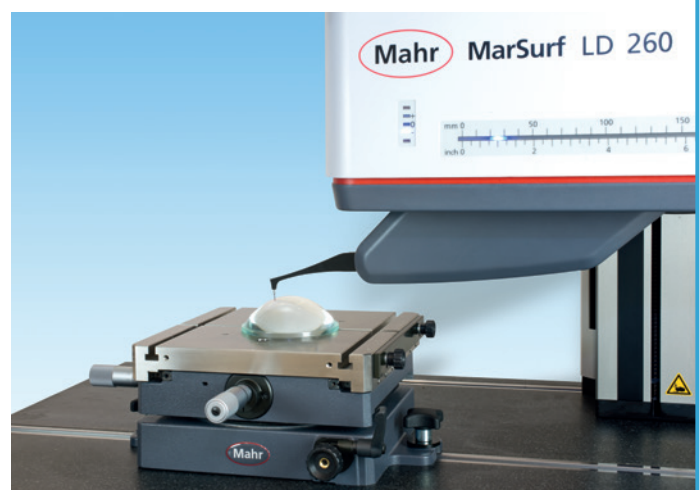
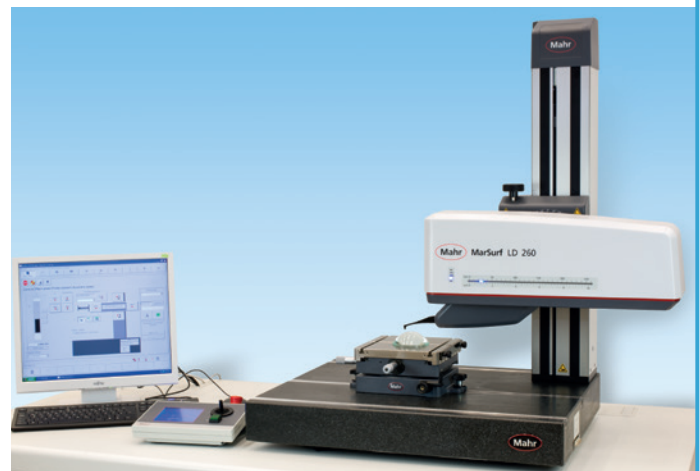

## MarSurf LD 130/LD 260. Medical Industry



### Applications in the medical branch

- Contour and roughness measurement of the hip implants.
  - shaft with ball head
  - Insert
  - Socket
- Contour and roughness depth measurement of knee implants.
  - Femur implants
  - Inlay
  - Tibia implant
- Contour measurement on bone screws
- Contour and roughness measurement on tooth implants

### Measuring task: Hip joint implant

- Measurement of the ball head with MarSurf LD 130
- Measurement on contour and roughness
- Evaluation of the line form deviation as well as roughness depth structure

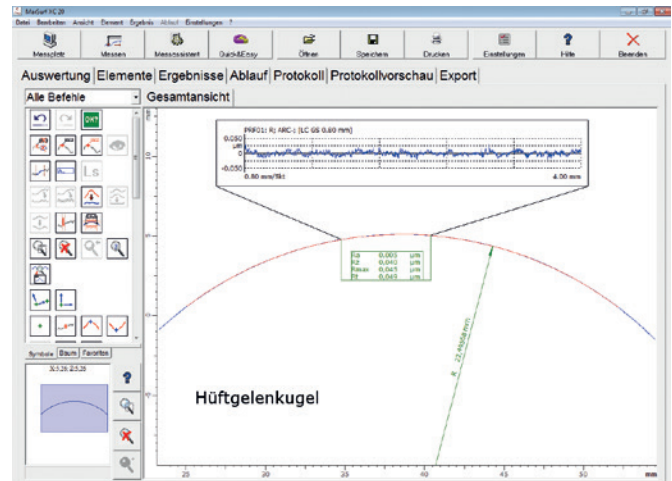
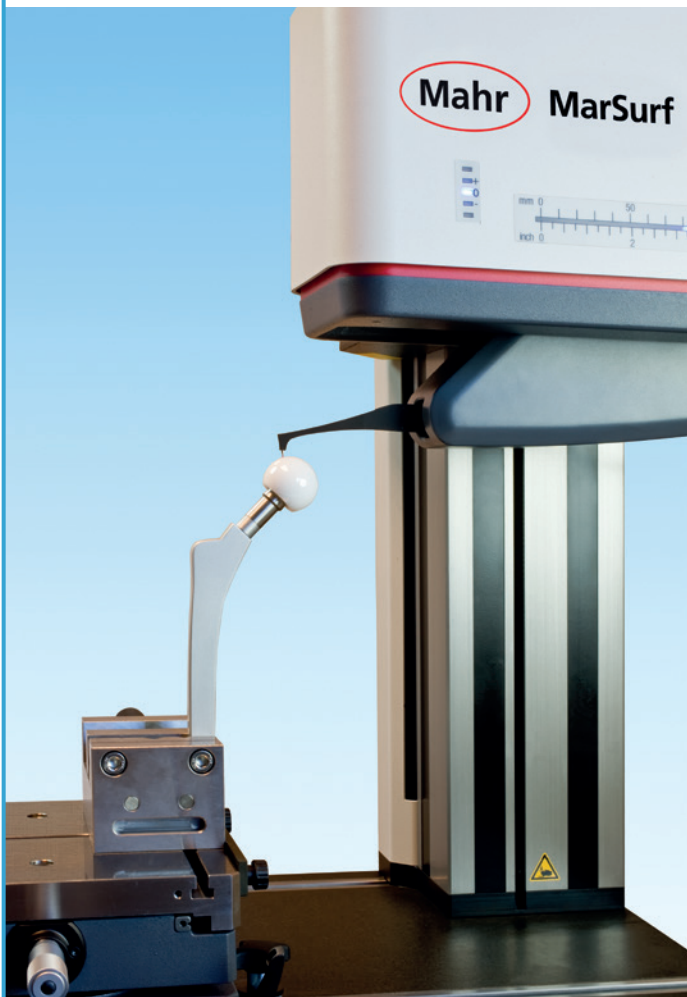

## MarSurf LD 130/LD 260. The Step into a New Dimension

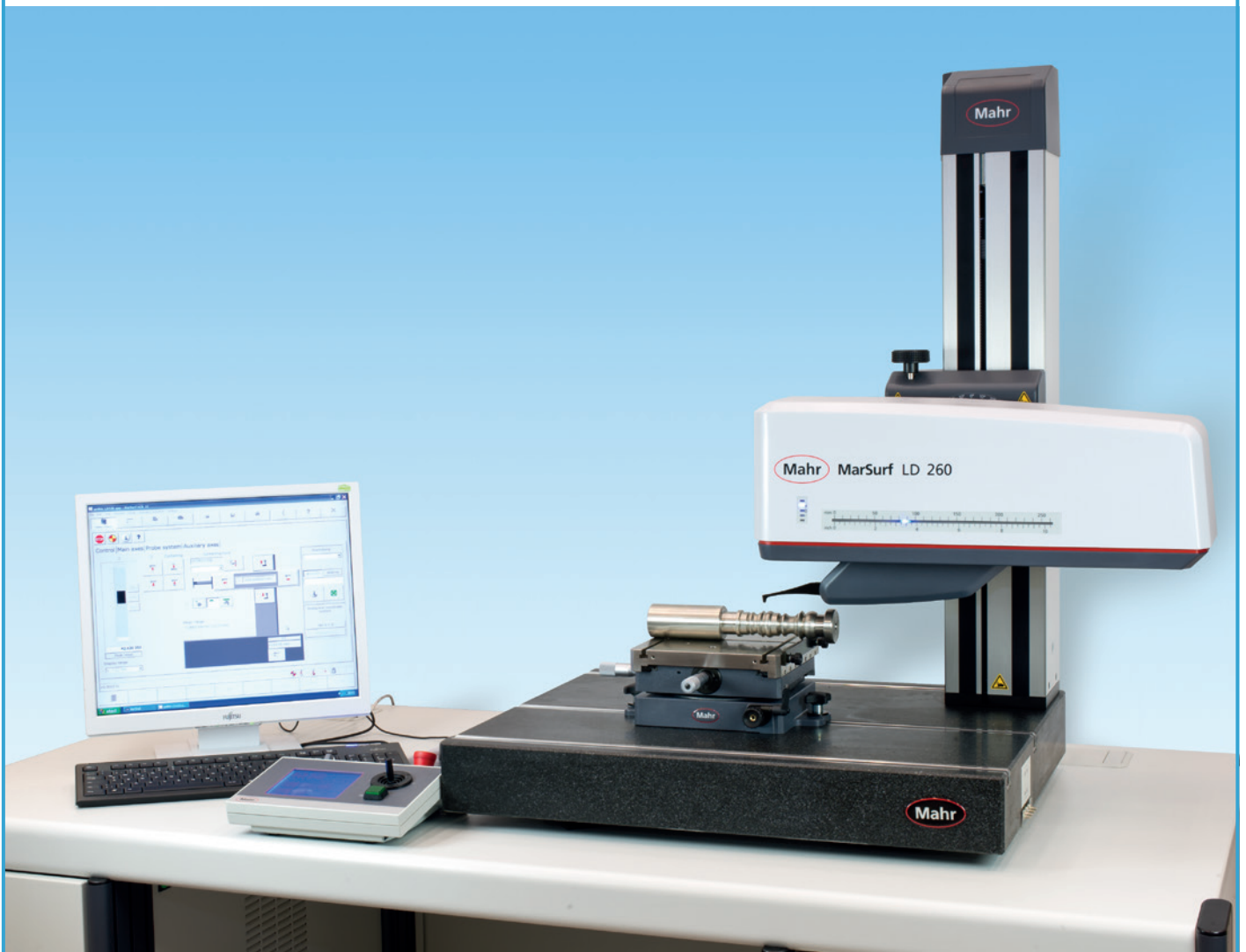

### Much success with the top unit from Mahr

- You save time:** due to high measuring and positioning speeds
- You can do more:** due to large measuring volume – long measuring paths – large measuring stroke
- You measure reliably:** due to the innovative probe system with bionic probe arm design  
due to the magnetic probe arm holder and reliable probe arm recognition thanks to chip technology
- You are reliable:** due to the service-friendly concept of the modular design

WWW.MAHR.COM

|  
- 0 +

**Mahr**

E X A C T L Y

**Mahr GmbH Göttingen**

Carl-Mahr-Str. 1, 37073 Göttingen, Germany  
Phone: +49551 70 73-800, Fax: +49551 70 73-888  
info@mahr.com, www.mahr.com

© by Mahr GmbH, Göttingen  
We reserve the right to make changes to our products, especially due to technical improvements and further developments. All illustrations and technical data are therefore without guarantee.