

Calipers

An industry standard measuring tool

ABSOLUTE Low Force Caliper SERIES 573

MeasurLink[®] ENABLED
Data Management Software by Mitutoyo

- An ABSOLUTE electromagnetic induction linear encoder system is incorporated.
- Due to the low measuring force, these calipers are ideal for measuring elastic workpieces such as plastic parts and rubber parts that standard calipers cannot measure accurately.
- Allows fine feeding easily by using thumb roller.
- Displacement of main scale jaw is 0.3 mm.
- Measuring force: 0.49 N to 0.98 N (50 gf to 100 gf)
- Absolute type. (Refer to page D-8 for a description of Absolute measurement.)
- Allows integration into statistical process control and measurement systems for models with measurement data output connector. Refer to page A-3.



573-191-30

SPECIFICATIONS

Metric			Inch/Metric		
Order No.	Range	Accuracy*	Order No.	Range	Accuracy*
573-191-30	0 - 180 mm	±0.05 mm	573-291-20	0 - 7 in	±0.002 in

* Excluding quantizing error.
Note) Dedicated for outside measurement (depth bar is not fitted).

DIMENSIONS

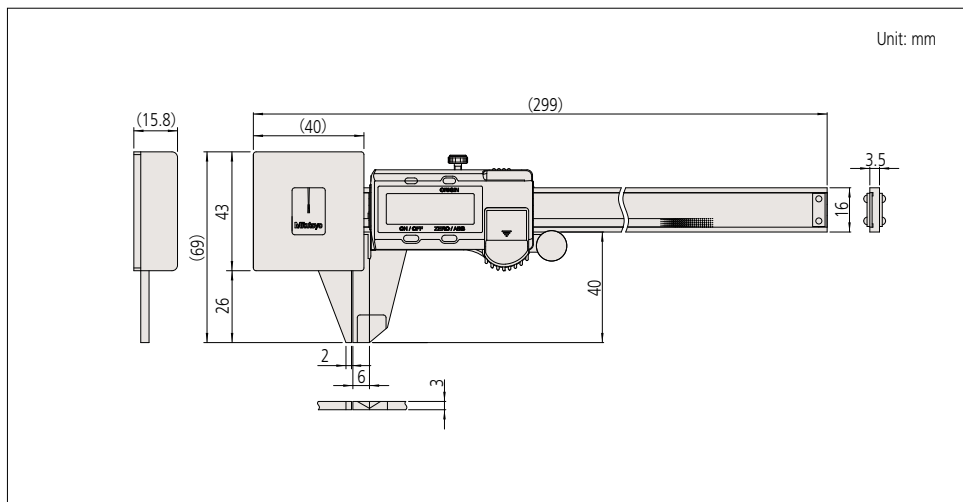

MeasurLink[®] ENABLED
Data Management Software by Mitutoyo

Products equipped with the measurement data output function can be connected to the measurement data network system MeasurLink (refer to page A-5 for details).

ABSOLUTE[™] (Refer to page X for details.)



Technical Explanation

Measurement procedure



A consistently low measuring force can be guaranteed by only taking measurements when the pointer is between the two fiducial lines.

Technical Data

Accuracy: Refer to the list of specifications. (excluding quantizing error)
Resolution: 0.01 mm or 0.0005 in / 0.01 mm
Display: LCD
Scale type*: ABSOLUTE electromagnetic inductive linear encoder
Jaw retraction: 0.3 mm
Max. response speed: Unlimited
Battery: **SR44** (1 pc, **938882**, for initial operational checks (standard accessory))
Battery life: Approx. 3.5 years under normal use

Optional accessories

For details, refer to page D-39.
959143: Data hold unit
Connecting cables for IT/DP/MUX
959149: SPC cable with data button (1 m)
959150: SPC cable with data button (2 m)
USB Input Tool Direct
06AFM380C: SPC cable for **USB-ITN-C** (2 m)
Wireless data output **U-WAVE[™] fit**
U-WAVE-TC: **264-620** (IP67 type)
264-621 (Buzzer type)
Connecting unit for U-WAVE-TC:
02AZF310 (IP67 type)
02AZF300 (Buzzer type)
Refer to page A-15 for details