

**ONOSOKKI**

# **CT-6700**

**DIGITAL ENGINE TACHOMETER**

**Instruction Manual**

**ONO SOKKI CO., LTD.**

---

WORLDWIDE ONO SOKKI CO., LTD.

1-16-1 Hakusan, Midori-ku, Yokohama 226-8507, Japan

Phone : +81-45-935-3918 / Fax : +81-45-930-1808 (Overseas sales department)

E-mail : [overseas@onosokki.co.jp](mailto:overseas@onosokki.co.jp)

---

## ■ WARRANTY ■

1. This product is covered by a warranty for a period of one year from the date of purchase.
  2. This warranty covers free-of-charge repair for defects judged to be the responsibility of the manufacturer, i.e., defects occurred while the product is used under normal operating conditions according to descriptions in this manual and notices on the unit label.
  3. For free-of-charge repair, contact either your sales representative or our sales office nearby.
  4. The following failures will be handled on a fee basis even during the warranty period.
    - (a) Failures occurring through misuse, mis-operation, or modification
    - (b) Failures occurring through mishandling (dropping) or transportation
    - (c) Failures occurring through natural calamities (fires, earthquakes, flooding, and lightning), environmental disruption, or abnormal voltage.
- \* For repairs after the warranty period expired, contact your sales representative or our sales office nearby.
- \* Outer appearance and specifications are subject to change without prior notice.
- 

- This document may not be reproduced, in whole or part, in any form or by any means without the prior written permission of the publisher.
  - The contents of this document are subject to change without notice.
  - This document has been produced based on a series of strict verifications and inspections. Should a failure occur nonetheless, please inform our sales representative or sales office.
  - Ono Sokki shall have no liability for any effect resulting from any operation, whether or not the effect is attributable to a defect in the documentation.

---

# Introduction

This manual describes the basic operation procedures, precautions, functions and specifications for the CT-6700 digital engine tachometer.

To ensure safe and proper use of the CT-6700 digital engine tachometer, be sure to read and understand warnings and precautions in this manual before using the product.

Ono Sokki, Co. Ltd. bears no responsibility for any damages resulting from negligence of the instructions given in this guide.

This document only describes the main unit of the CT-6700 digital engine tachometer and its options. For the details of individual equipment (sensors and peripherals) to combine with the CT-6700 digital engine tachometer, refer to the instruction manual for each equipment.



## ● How to Use this manual

This manual uses the following symbols in addition to safety symbols. Before reading the instructions in this guide, be sure to understand them.



CAUTION

Indicates supplementary explanations or restrictions. It is recommended to read the information followed by this symbol.



Important

Indicates important instructions that need to be observed. Be sure to read the instructions followed by this symbol.



CAUTION

- The contents of this document are subject to change in future editions without prior notice.
- No part of this document may be reprinted or reproduced without prior permission from Ono Sokki.
- While the contents of this document have been prepared in our best efforts for perfection, should there be any unclear point, error, or any other questionable point, please advise us of them.
- Please be advised that we should not be responsible for results of your operation, regardless of the preceding paragraph.
- All corporate names and product names used herein are either trade names or registered trade names of their respective holders.

# For Your Safety

- Read this manual before using the CT-6700 digital engine tachometer.
- When using the CT-6700 digital engine tachometer, observe the instructions in this manual.
- Some of the precautions specific to the CT-6700 digital engine tachometer might be described on the main unit itself or in the supplementary manuals other than this manual. Be sure to follow these precautions to ensure your safety.
- Keep this manual in a safe place where it is readily available for future reference.
- Note that this manual merely covers the information at the time of publication, thus contact information (such as company address, phone number, website URL, and e-mail address) may be changed without prior notice.

## ● Safety Symbols

In this manual the safety precautions are classified into the following categories.

Each category indicates the degree of hazard caused by negligence of the suggested precautions.







 **WARNING** Failure to follow the precaution results in death or serious injury.

 **CAUTION** Failure to follow the precaution results in moderate injury or property damage.

 **NOTICE** Failure to follow the precaution cannot lead not to personal injury but can damage your property, including the system, facilities or equipment.

## ● Meanings of Symbols

Precautions and notices for danger are given by three different symbols: Attention, Prohibition, and Mandatory. Each symbol has the following meaning.

Symbol	Definition	Meaning	Example
	Attention	Indicates that failure to follow the instruction could lead to a risk of danger. The drawing in the symbol indicates the type of danger involved.	
	Prohibition	Indicates actions that must not be taken. The drawing in or near the symbol indicates the action that is prohibited.	
	Mandatory	Indicates an action that is mandatory. The drawing in or near the symbol indicates the mandatory action to avoid the hazard.	

## ■ Precautions on Usage

 **CAUTION**

-  Do not use the product for operations that can lead to death or require high levels of reliability.
- The CT-6700 digital engine tachometer is not intended to be part of or to control facilities or devices, the use of which can lead to death or requires high levels of reliability, such as medical equipment, nuclear power facilities and equipment, aerospace systems, and transport facilities and equipment.
- Ono Sokki Co., Ltd. shall not be held liable for any injury, death or property damage resulting from using the CT-6700 digital engine tachometer with these facilities, equipment or control systems.

---

## ■ Precautions on Use

### WARNING



Do not handle the CT-6700 digital engine tachometer with wet hands.

---

### CAUTION



Do not disassemble the CT-6700 digital engine tachometer.

- If the product requires disassembling due to failure or modification, please contact the nearest Ono Sokki sales office or the distributor where you purchased the product.
- 



Do not expose the CT-6700 digital engine tachometer to water.

- If the product is exposed to water, immediately stop using it and contact the nearest Ono Sokki sales office or the distributor where you purchased the product.
- 

## ■ Precautions on Power Supply

### CAUTION



AC adapter

- Be sure to use the specified AC adapter. Using an AC adapter other than the specified one may result in electric shock or fire.
- 

On-vehicle battery

- If the power is supplied from a battery (12–24 V), use the power cable for the LC-0865 cigarette lighter socket or for the LC-0082 battery. Using an AC adapter other than the specified one may result in electric shock or fire.
- 

Other DC power

- If the power is supplied from the AC adapter or the DC power other than a battery, consult the nearest Ono Sokki sales office or the distributor where you purchased the product.
- 

## ■ Precautions on Disposal

### CAUTION



When disposing the CT-6700 digital engine tachometer or its accessories, be sure to observe relevant local laws and regulations.

- For details, please contact your local authorities.
- 

## ■ Notice about electromagnetic environment

### CAUTION



This product is intended the equipment to be used in industrial electromagnetic environment.

This is a class A product. In a domestic environment this product may cause radio interference in which case the user may be required to take adequate measures.

---

## ■ Precautions on Storage

### ⚠ NOTICE



CT-6700 digital engine tachometer is a precision electronic equipment. Do not leave it in a place where temperature becomes excessively high or low.

## ■ Precautions When Mounting Optional Sensors

### ⚠ WARNING



Before installing or removing an optional sensor, make sure that the engine is stopped.

- Working on the rotating engine is very dangerous since your hand or clothes might be caught in.



The engine right after it is stopped is at a very high temperature. Before installing or removing the optional sensor, make sure that the engine is cooled off.

- Otherwise, it might cause burns.



CAUTION

- Before mounting an optional sensor to the engine, refer to the relevant instruction manual for other precautions.

## ■ Safety Symbols and Caution Labels

The following describes the positions and meanings of the safety symbols and their meanings shown on the closure (rear panel) of the CT-6700 digital engine tachometer. Be sure to read and understand them before using your tachometer.

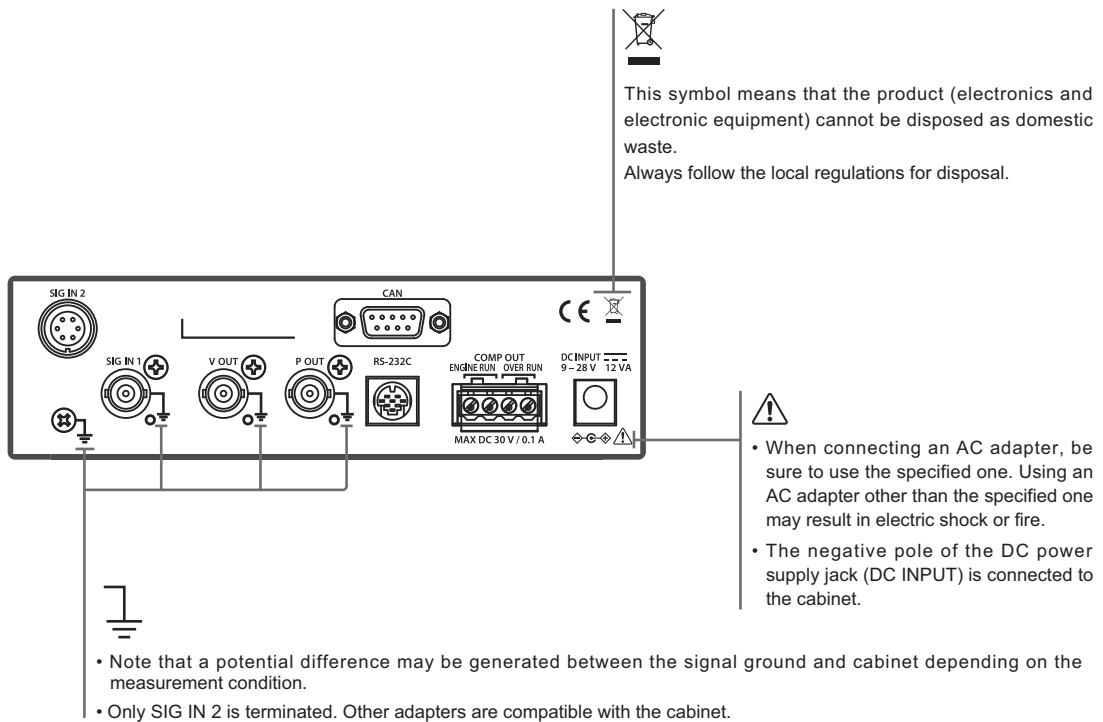

# Checking Supplied Items

After receiving the product, make sure that the package includes the following items:

## ■ Supplied Items

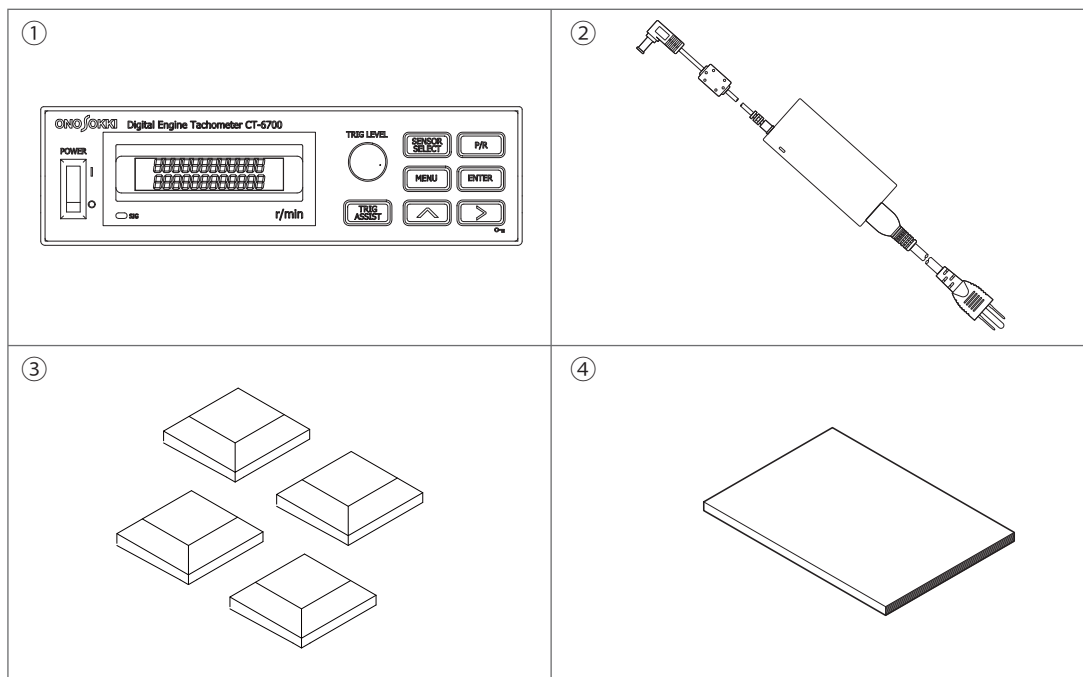

Symbol	Name	Quantity	Remarks
①	CT-6700 digital engine tachometer	1	
②	AC adapter	1	AC adapter main unit and AC cable
③	Rubber feet	4	Not attached Refer to "Mounting on a Desk" on page 23.
④	Instruction manual (English)	1	This manual



- If any of the items is missing or damaged, immediately contact the nearest Ono Sokki sales office or the distributor where you purchased the product.
- The above items are supplied with the standard unit. Optional equipment or software is not included.

---

# Contents

Introduction .....	1
For Your Safety .....	2
Checking Supplied Items .....	5

---

## **Chapter 1 Overview of CT-6700**

---

1. Overview and Features .....	10
1.1 Overview and Features of CT-6700 .....	10
2. Component Names and Functions .....	11
2.1 Front Panel .....	11
2.2 Rear Panel .....	13
3. Names of Screens and Display Items .....	15
3.1 CT-6700 Screens .....	15
3.2 Component Names and Functions of Measurement Mode Screen .....	16
3.3 Component Names of Menu Mode Screen .....	17
4. System Configuration .....	18
4.1 Example of Measurement System Configuration of CT-6700 and Peripherals .....	18
4.2 Applicable Sensors .....	19
4.3 Optional Equipment .....	20

---

## **Chapter 2 Preparation and Measurement of CT-6700**

---

1. Measurement Procedure of CT-6700 .....	22
2. From Installation to Complete Measurement .....	23
2.1 Installation .....	23
2.2 Connecting Power Supply .....	26
2.3 Installing and Connecting Sensors .....	28



---

2.4	Connecting Peripheral Units.....	32
2.5	Powering Up .....	34
2.6	Setting General Conditions in the Sensor Select Mode and Pulse Setup Mode.....	34
2.7	Adjusting Trigger Level and Checking Operation .....	37
2.8	Starting and Finishing Measurement.....	39
2.9	Removing and Storing Equipment .....	40

---

## Chapter 3 Mode and Menu Reference

---

1.	Menu Mode Reference .....	42
1.1	Overview of Menu Mode .....	42
1.2	Trigger Level Setup Mode (TRIG).....	45
1.3	Sensor Select Mode (SENSOR SELECT).....	45
1.4	Pulse Setup Mode (P/R) .....	45
1.5	Trigger Assist Mode (TRIG ASSIST).....	46
1.6	ECU Crank Pulse Calibration Mode (CRANK PULSE CAL) .....	46
2.	Menu Reference.....	48
2.1	List of Menu Structure.....	48
2.2	Version Display (0: VERSION).....	49
2.3	Setting Measurement Conditions (1: MEAS) .....	49
2.4	Setting Pulse Output Conditions (2: P-OUT) .....	52
2.5	Setting Output Voltage Conditions (3: V-OUT) .....	52
2.6	Setting Comparator Output Conditions (4: COMP-OUT) .....	53
2.7	Setting Display Conditions for Fluorescent Display Tube (5: DISPLAY) .....	56
2.8	Setting RS-232C Interface Conditions (6: RS-232C) .....	58
2.9	Setting Memory Conditions (7: COND MEMORY) .....	59
2.10	Setting Calibration Conditions (8: CAL) .....	60
2.11	Setting CAN Output Conditions (9: CAN-OUT) .....	61

---

## Chapter 4 Interface Reference

---

1.	RS-232C Interface .....	64
1.1	Overview of RS-232C Interface.....	64
1.2	RS-232C Command Reference.....	66

---

2.	CAN Interface .....	71
2.1	Overview of CAN Interface .....	71
2.2	CAN Data Format .....	73

---

## Chapter 5 Reference Materials

---

1.	Specifications .....	76
1.1	Display Unit.....	76
1.2	Input.....	76
1.3	Analog Output.....	76
1.4	Pulse Output .....	77
1.5	Contact Output.....	77
1.6	RS-232C.....	77
1.7	CAN (Optional CT-0671 CAN Output).....	78
1.8	Other Functions.....	78
1.9	General Specifications.....	78
1.10	Conforming Standards .....	79
1.11	Pulse Count per Revolution (P/R) and r/min Range .....	79
2.	Outside Dimension Diagram .....	80
3.	Error Messages and Corrective Actions Taken .....	81
	Index.....	83

# Chapter 1

## Overview of CT-6700

1. Overview and Features	10
2. Component Names and Functions	11
3. Names of Screens and Display Items	15
4. System Configuration	18

# 1. Overview and Features

## 1.1 Overview and Features of CT-6700

The CT-6700 digital engine tachometer is a digital tachometer to measure revolution speed of gasoline or diesel engines, motors (EV/HEV) equipped on electric vehicles or hybrid electric vehicles or general rotating bodies. This product supports various sensors with different usages and purposes. The CT-6700 digital engine tachometer can be mounted on a panel in addition to a desk or a vehicle, so it can be built into control panels.

### ■ Features

- Various sensors with different usages and purposes are supported  
The following sensors can be connected to the CT-6700 digital engine tachometer.

Measurement object	Supported sensor
Gasoline	IP-292/296/3000A/3100 ignition pulse detector
	OM-1200/1500 motor/gasoline engine RPM detector
	VP-202/1220 engine vibration detector
	Crank angle signal for ECU (optional)
Diesel engine	VP-202/1220 engine vibration detector
	Crank angle signal for ECU (optional)
Motor installed on electric or hybrid electric vehicle (EV/HEV)	OM-1200/1500 motor/gasoline engine RPM detector
General rotating body	LG-9200/930 optical detector
	MP-981 magnetic detector
	MP-900/9000 series electromagnetic detector

- Featured with analog output function (V-OUT)  
Outputs analog signal.
- Featured with pulse output function (P-OUT)  
Outputs pulse signal.
- Equipped with two types of interfaces (RS-232C/CAN)  
It comes with RS-232C as a standard.  
If the optional CT-0671 CAN output is added, the CAN output interface can be used.
- Automatic setting of trigger level with the trigger assist function  
Manual setting is also supported to set a desired trigger level.
- Equipped with condition memory  
The condition memory can save/load up to five condition setting values (parameters necessary for measurement)

## 2. Component Names and Functions

### 2.1 Front Panel

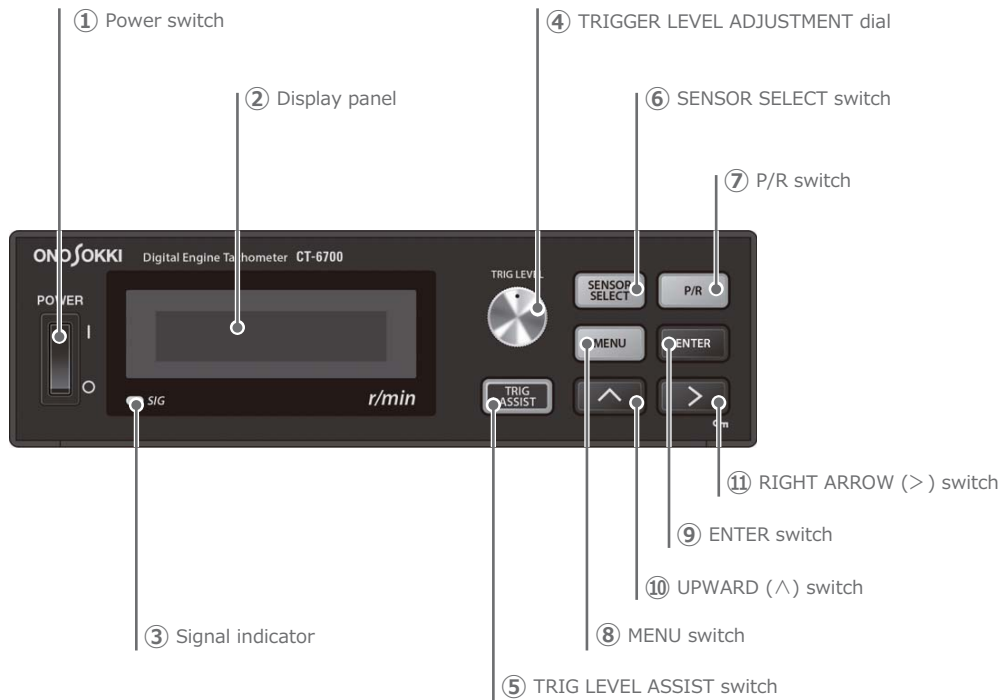

- ① **POWER:** Power switch  
Turn the power switch of the CT-6700 digital engine tachometer from ON (I) to OFF (O).



- When you change the condition setting in the menu mode, wait for over 3 seconds before turning off the power switch (O).  
If you turn off the power switch within 3 seconds after changing the conditions, they will not be validated.

- ② **Display panel (fluorescent display tube)**  
Displays the menu to show measured values or to set conditions.  
For details, refer to “3. Names of Screens and Display Items” on page 15.
- ③ **SIG:** Signal indicator  
Lights or flashes when the revolution signal from the sensor is detected.
- ④ **TRIG LEVEL:** TRIGGER LEVEL ADJUSTMENT dial  
Dial to adjust the trigger level.  
In the setting mode, it can also be used to select items or change values.  
For details, refer to “1.2 Trigger Level Setup Mode (TRIG)” on page 45.

- ⑤ TRIG ASSIST: TRIG LEVEL ASSIST switch  
Switch to auto adjust the trigger level.  
For details, refer to "1.5 Trigger Assist Mode (TRIG ASSIST)" on page 46.
  
- ⑥ SENSOR SELECT: SENSOR SELECT switch  
Switch to select the connected sensor.  
For details, refer to "1.3 Sensor Select Mode (SENSOR SELECT)" on page 45.
  
- ⑦ P/R: P/R switch  
Switch to set the number of pulses.  
For details, refer to "1.4 Pulse Setup Mode (P/R)" on page 45.
  
- ⑧ MENU: MENU switch  
Switch to toggle between the measurement mode and the menu mode.  
For details, refer to "2. Menu Reference" on page 48.
  
- ⑨ ENTER: ENTER switch  
Switch to confirm the condition settings in the menu mode.  
For details, refer to "Setting Operation for Conditions and Values in Menu Mode" on page 42.
  
- ⑩ UPWARD (^) switch  
Switch to select the condition settings in the menu mode.  
For details, refer to "Setting Operation for Conditions and Values in Menu Mode" on page 42.

- ⑪ RIGHT ARROW (>) switch/ (⏏) Key protect switch  
These have two functions shown below.

Operation	Description
Press once	Switch to move the selection cursor in the menu mode. For details, refer to "Setting Operation for Conditions and Values in Menu Mode" on page 42.
Hold	Pressing more than one second enables (⏏)/disables the key protect feature.

## 2.2 Rear Panel

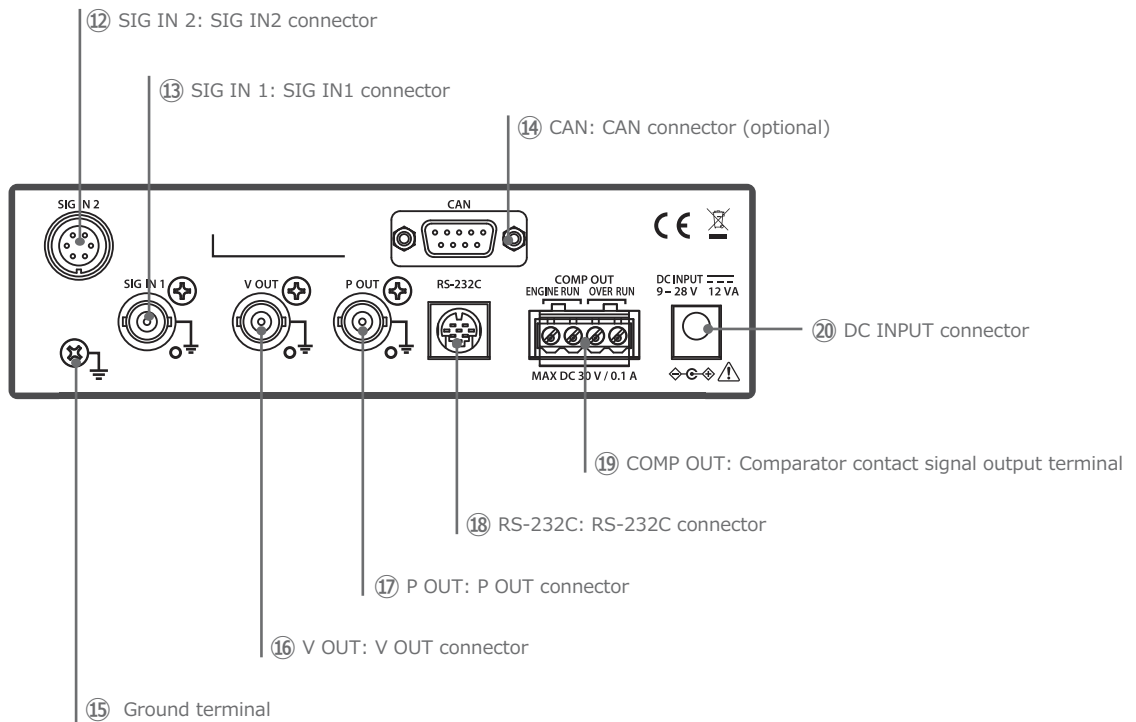

⑫ SIG IN 2: SIG IN2 connector

Connects the MP-981 magnetic detector, the LG-9200/930 Optical detector or the ECU crank pulse signal (when the optional CT-0672 ECU crank pulse signal input is installed).

⑬ SIG IN 1: SIG IN1 connector

The BNC connector to connect the sensors (the IP-292/296/3000A/3100 ignition pulse detector, the OM-1200/1500 Motor/gasoline engine RPM detector, the VP-202/1220 Engine vibration detector or the MP-900/9000 series electromagnetic detector).

⑭ CAN: CAN connector (optional)

The CAN interface connector available when the optional CT-0671 CAN output is installed. CAN stands for Controller Area Network.

For details on setting conditions for the CAN interface, refer to "2.11 Setting CAN Output Conditions (9: CAN-OUT)" on page 61.

For details on the overview and the specification of the CAN interface, refer to "2. CAN Interface" on page 71.

⑮ Ground terminal (⊥)

This terminal is used for functional grounding.



- If you are using the product mounted on a vehicle, connect the unit to the functional ground terminal and the vehicle as necessary.

⑩ V OUT: V OUT connector

The connector for voltage output. The applicable connector type is BNC.

For details on connection, refer to "Connection to V-OUT (Voltage Output Connector)" on page 33.

Also, for details on output setting conditions, refer to "2.5 Setting Output Voltage Conditions (3: V-OUT)" on page 52.

⑪ P OUT: P OUT connector

The connector for pulse signal output. The applicable connector type is BNC.

For details on connection, refer to "Connection to P-OUT (Pulse Output Connector)" on page 33.

Also, for details on output setting conditions, refer to "Setting Pulse Output Conditions (2: P-OUT)" on page 52.

⑫ RS-232C: RS-232C connector

The connector to RS-232C interface.

For details on setting conditions for the RS-232C interface, refer to "2.8 Setting RS-232C Interface Conditions (6: RS-232C)" on page 58.

Also, for details on RS-232C commands, refer to "1. RS-232C Interface" on page 64.

⑬ COMP OUT (ENGINE RUN/OVER RUN): Comparator contact signal output terminal

The contact signal output terminal for the comparator signal (ENGINE RUN or OVER RUN)

For details on connection, refer to "Connecting to COMP OUT (Comparator Contact Output Terminal)" on page 33.

Also, for details on output setting conditions, refer to "2.6 Setting Comparator Output Conditions (4: COMP-OUT)" on page 53.

⑭ DC INPUT: DC INPUT connector

The connector for power supply.

Two types of power supplies, the AC adapter accessory or the battery can be used.

For details, refer to "2.2 Connecting Power Supply" on page 26.



### 3. Names of Screens and Display Items

#### 3.1 CT-6700 Screens

All of the screens displayed on the CT-6700 digital engine tachometer are shown below.

There are two types of screens on the CT-6700 digital engine tachometer: the measurement mode to show the input signal value from sensors, and the menu mode to set conditions.

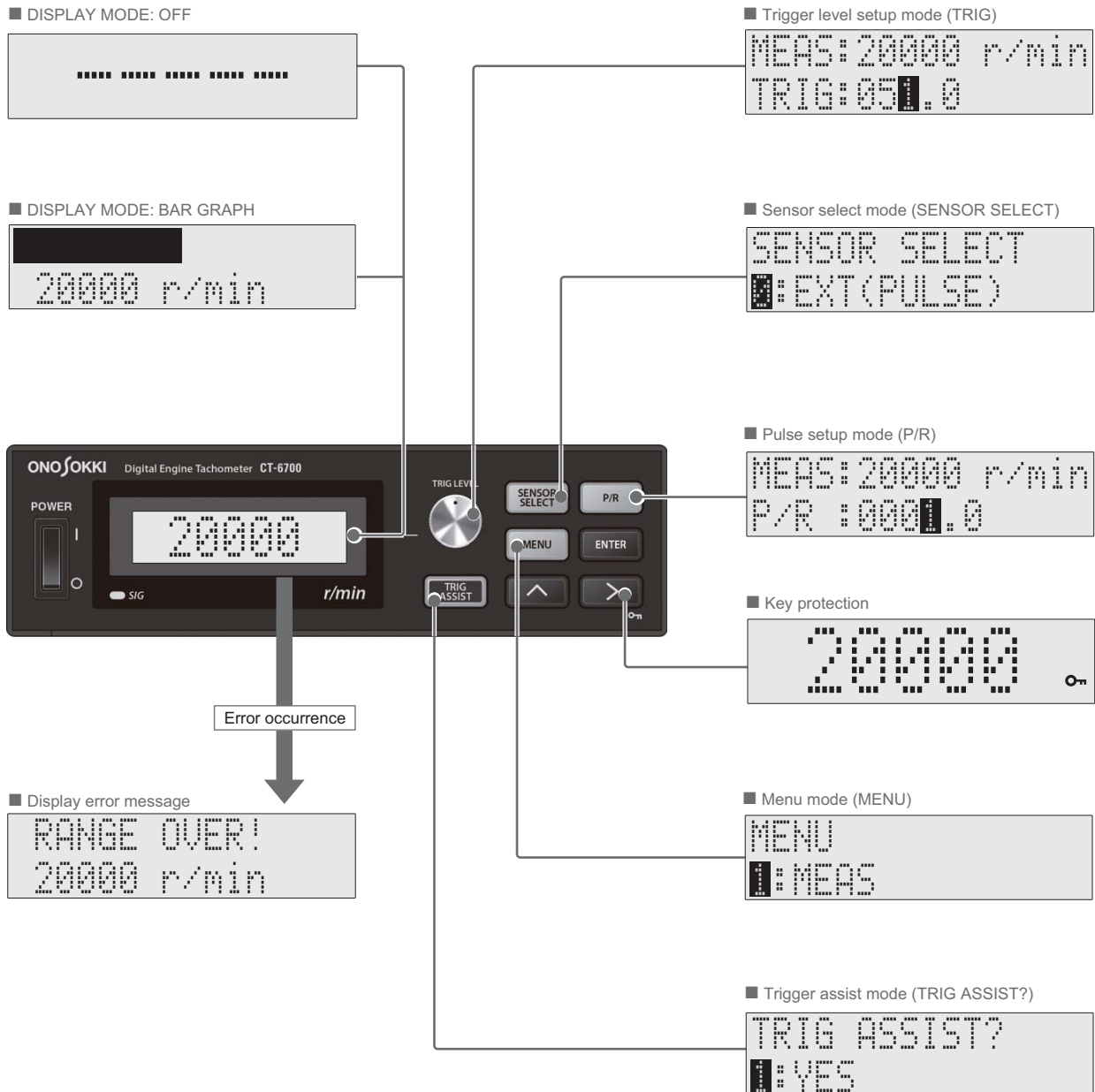

## 3.2 Component Names and Functions of Measurement Mode Screen

Turn the power switch of the CT-6700 digital engine tachometer from ON (I) to OFF (O). It starts in the measurement mode.

The measurement mode has three types of displays: NORMAL, BAR GRAPH and OFF. You can toggle between them in the menu mode. For details, refer to “Setting Display Mode for Measurement Mode (2: MODE)” on page 57.

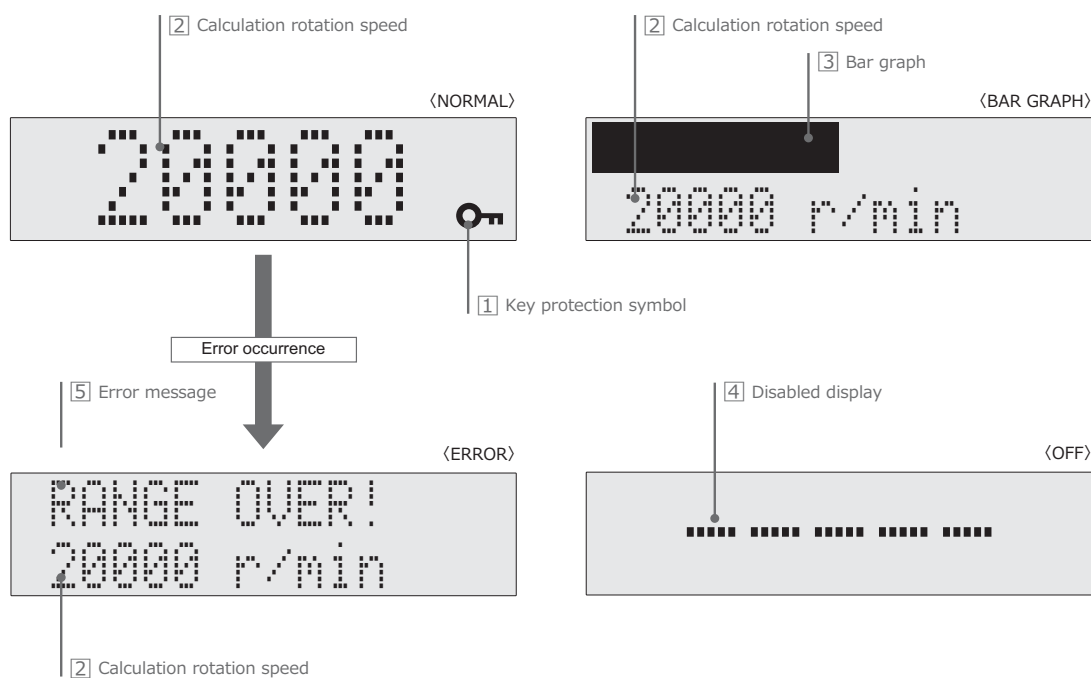

- 1 Key protection symbol (Ⓚ)
 

Key protect symbol (Ⓚ) is shown when the key protect mode is enabled.
- 2 Calculation rotation speed
 

Shows the calculation rotation speed from sensors in an integer value (0 to 99999).  
When BAR GRAPH is selected, the calculation rotation speed is shown with the unit (r/min) in the lower column among the two columns.
- 3 Bar graph
 

A bar chart is shown when BAR GRAPH is selected. The display expands/shrinks according to the increase/decrease of the calculation rotation speed.
- 4 Disabled display
 

When set to OFF, the disabled symbol (-) is shown as the calculation rotation speed.
- 5 Error message
 

When an error occurs, two columns are shown. The error message is shown in the upper column and the calculation rotation speed value (0 to 99999) is shown in the lower column.  
When BAR GRAPH is selected, the error message is shown in the display area of the bar chart.  
For details on error messages, refer to “3. Error Messages and Corrective Actions Taken” on page 81.

### 3.3 Component Names of Menu Mode Screen

The menu mode is the screen to set conditions for the CT-6700 digital engine tachometer. You can toggle between the measurement mode and the setting mode by operating the dial or the switch.

#### ■ Trigger Level Setup Mode (TRIG)

Turn the TRIGGER LEVEL ADJUSTMENT dial to the right/left to display the trigger level setup mode (TRIG) with the measurements on the upper column and the trigger level in the lower column. For details, refer to “1.2 Trigger Level Setup Mode (TRIG)” on page 45.

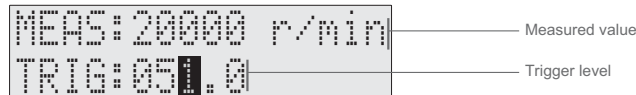

#### ■ Sensor Select Mode (SENSOR SELECT)

Press the SENSOR SELECT switch to enter the sensor select mode (SENSOR SELECT). For details, refer to “1.3 Sensor Select Mode (SENSOR SELECT)” on page 45.



#### ■ Pulse Setup Mode (P/R)

Press the P/R switch to enter the pulse setup mode (P/R). For details, refer to “1.4 Pulse Setup Mode (P/R)” on page 45.

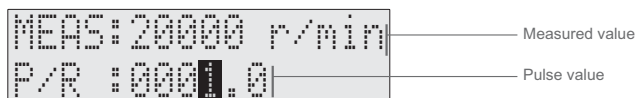

#### ■ Trigger Assist Mode (TRIG ASSIST) and ECU Crank Pulse Calibration Mode

Press the TRIG ASSIST switch to enter the trigger assist mode (TRIG ASSIST). For details, refer to “1.5 Trigger Assist Mode (TRIG ASSIST)” on page 46.



If the optional CT-0672 ECU crank pulse input is installed, press the TRIG ASSIST switch to enter the ECU crank pulse calibration mode (CRANK PULSE CAL). For details, refer to “1.6 ECU Crank Pulse Calibration Mode (CRANK PULSE CAL)” on page 46.



#### ■ Menu Mode

The menu mode is the mode to set details of conditions. You can enter the menu mode by pressing the MENU switch in the measurement mode. For details, refer to “2. Menu Reference” on page 48.

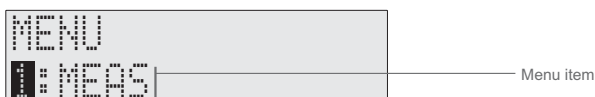

# 4. System Configuration

## 4.1 Example of Measurement System Configuration of CT-6700 and Peripherals

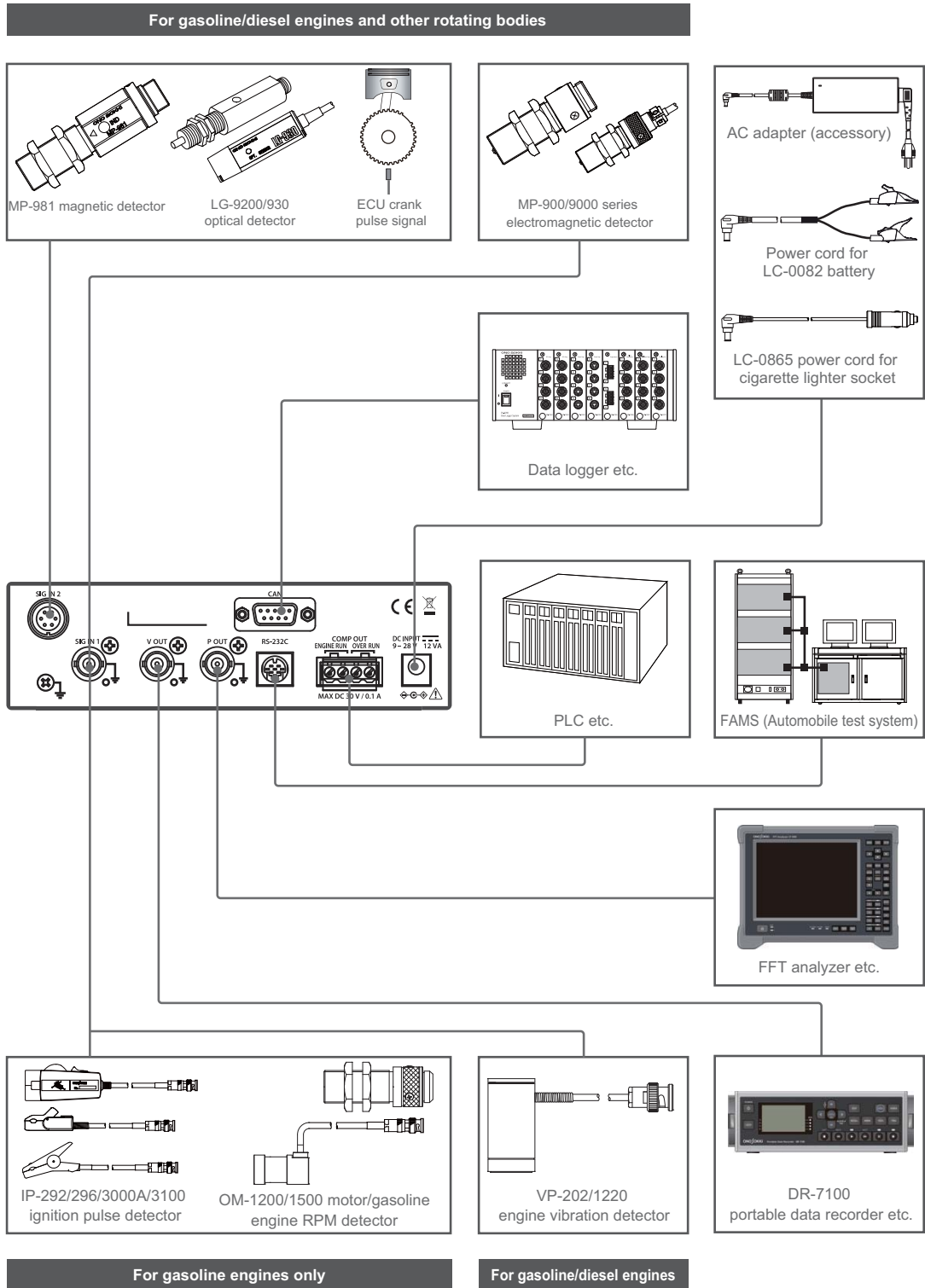

## 4.2 Applicable Sensors

The following sensors can be connected to the CT-6700 digital engine tachometer.

Measurement object	Model	Connector	Detection principle and installation overview
For gasoline engines (exclusive)	IP-292/296 Ignition pulse detector	SIG IN 1	Detects spark signal from the ignition system via the ignition coil cable.
	IP-3000A/3100 Ignition pulse sensor	SIG IN 1	<ul style="list-style-type: none"> <li>IP-292/3000A is used at the ignition coil low-voltage primary side.</li> <li>IP-296 is used at the high-voltage secondary side ignition.</li> <li>IP-3100 is used at the low-voltage primary side and the high-voltage secondary side ignition.</li> </ul>
	OM-1200/1500 Motor/gasoline engine RPM detector	SIG IN 1	Detects leakage magnetic flux from the magnet engine shaft with the magnet ignition system. <ul style="list-style-type: none"> <li>Installed in parallel with and approx. 30 mm apart from the ignition coil.</li> <li>Set the input pulse count according to the number of magnets.</li> </ul>
For gasoline engines and Diesel engines (for both)	VP-202/1220 Engine vibration detector	SIG IN 1	Detects vibration due to vertical motion of the piston, based on the galvanic electricity vibration detection method. <ul style="list-style-type: none"> <li>With the magnet on the bottom, attach to the cylinder head bolt or engine mounting bolt.</li> <li>Cannot be used for engines with 6 or more cylinders.</li> </ul>
For gasoline engines and Diesel engines and Rotating bodies	MP-900/9000 series Electromagnetic detector	SIG IN 1	Electromagnetic induction sensor incorporating permanent magnet and sensor coil. <ul style="list-style-type: none"> <li>Located in proximity of the tip of the detection gear mounted on the shaft. Picks out frequency signal which is proportional to the r/min value.</li> </ul>
	LG-9200/930 Optical detector	SIG IN 2	Reflective type sensor using an opt-fiber at the top <ul style="list-style-type: none"> <li>The unit incorporates a photo emitter, photo receptor and the amplifier.</li> <li>Detects the r/min value by means of photo emission and reception of infrared light, which allows non-contact detection with the reflection mark attached on the shaft.</li> <li>The output connector of the LG-930 optical detector has open wires on one end, which needs to be processed for connection. For details, refer to the instruction manual which comes with the LG-930 photoelectric rotation sensor.</li> </ul>
	MP-981 Magnetic detector	SIG IN 2	A magnetic flux response type (resistance changes according to magnetic flux) sensor which incorporates a magnetic resistor, a permanent magnet, a DC amplifier, and a voltage regulator. <ul style="list-style-type: none"> <li>Detects a wide range of rpm from super slow to high speed in the form of square wave output, within 1 to 20,000 r/min (60 P/R).</li> </ul>
Others	TTL	SIG IN 1	Measures engine rotation using the TTL level signal from the external sensor.
	CRANK PULSE	SIG IN 2	Measures engine rotation using the ECU crank pulse signal. <ul style="list-style-type: none"> <li>Available when the optional CT-0672 ECU crank pulse signal input is installed.</li> </ul>



- For details on the cabling to each sensor, refer to our website (<https://www.onosokki.co.jp/English/english.htm>) or brochure of the sensors, or contact the nearest Ono Sokki sales office or the distributor where you purchased the product.

## 4.3 Optional Equipment

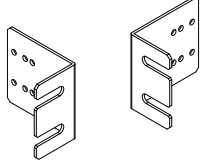
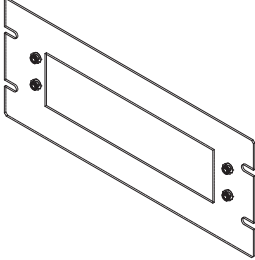
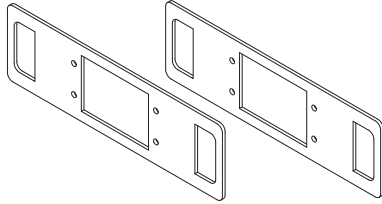
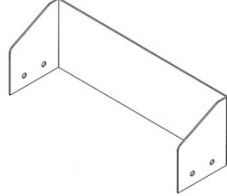
Model	Name	Remarks
CT-0671	CAN output	
LC-0082	Power cord for battery	
LC-0865	Power cord for cigarette lighter socket	
CT-0672	ECU crank pulse signal input	
CT-0673	Panel mount fitting	For installing to panel 
CT-0674	Panel mount jigs	Substitute for CT-6520B 
CT-0675	Protection handles	Used when mounted on vehicle 
CT-0676	Light shield	Prevents light reflections and glares. 



- For details on the optional accessories, contact the nearest Ono Sokki sales office or the distributor where you purchased the product.

# Chapter 2

## Preparation and Measurement of CT-6700

1. Measurement Procedure of CT-6700 22

2. From Installation to Complete Measurement 23

# 1. Measurement Procedure of CT-6700

This section describes the basic operational procedure from preparation to measurement of the CT-6700 digital engine tachometer.

The CT-6700 digital engine tachometer should be prepared and operated in the following procedure.

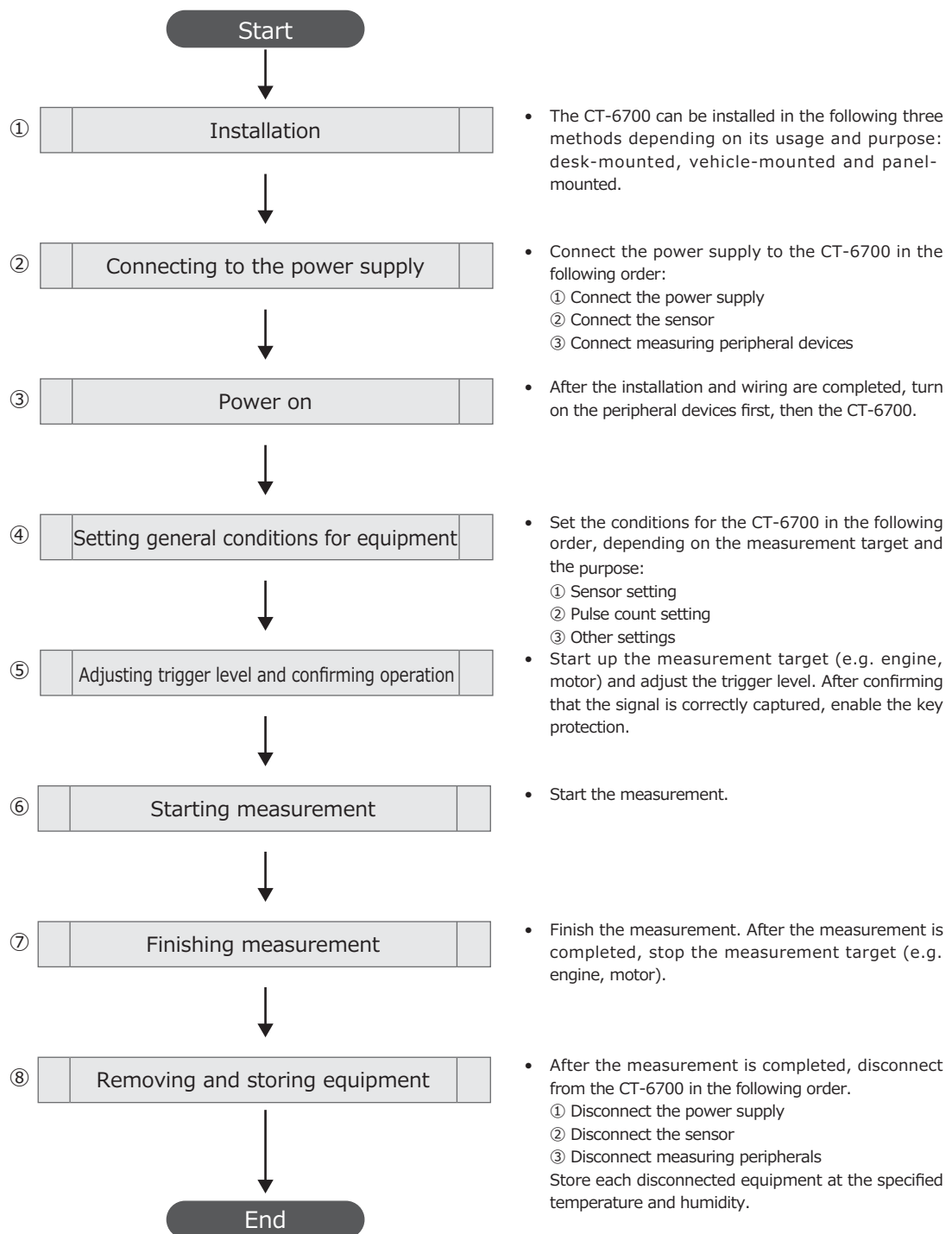



## 2. From Installation to Complete Measurement

This section describes each procedure in detail following the order shown in the flow chart in “1. Measurement Procedure of CT-6700” on page 22.

### 2.1 Installation

The CT-6700 digital engine tachometer can be used in the following three methods (desk-, vehicle- and panel-mounted) depending on the usage and purpose.

#### ■ Mounting on a Desk

The rubber feet accessory have the protection feature against slippage and vibration.

If you are using the CT-6700 digital engine tachometer mounted on a desk, attach the rubber feet (× 4) to the bottom of the main unit in the following order.

- 1** Turn over the CT-6700 digital engine tachometer and remove grease, water, dust and dirt from the surface that the rubber feet will be attached to.
- 2** Peel off the rubber feet from the sheet and attach them to the bottom of CT-6700 digital engine tachometer.  
Press the rubber feet hard with your thumb after attaching them.
- 3** Make sure the rubber feet are firmly fixed.

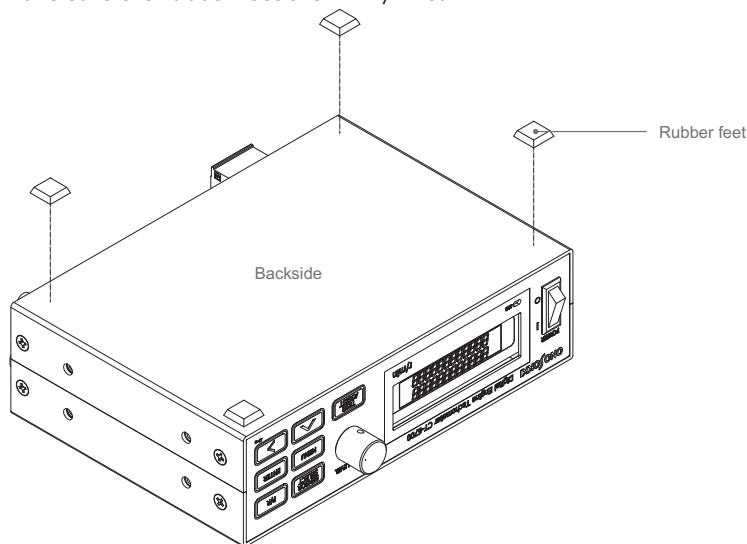

- Do not touch the adhesive surface of the rubber feet or reattach them since it decreases the adhesive force. This causes the rubber feet to come off easily. Purchase new ones when their adhesive force decreased. To purchase the rubber feet, contact the nearest Ono Sokki sales office or the distributor where you purchased the product.

#### ■ Mounting on a Vehicle



- If you place the CT-6700 unit on the dashboard, it may fall off while you are driving the vehicle. This may cause injury or damage the unit. When you use the CT-6700 unit on the vehicle, refer to the below figure and procedure and install it on the front passenger seat.



- You need to purchase the optional CT-0675 protection handle to mount the CT-6700 digital engine tachometer to a vehicle. For details on the optional accessories, contact the nearest Ono Sokki sales office or the distributor where you purchased the product. You also need the cable with hooks to fix the CT-6520B mounted on the vehicle.

Following the figure and the procedure below, attach the CT-6700 digital engine tachometer to the passenger seat of the vehicle.

- 1 Attach the optional CT-0675 protection handle to the CT-6700 digital engine tachometer. Attach the optional CT-0675 protection handle by driving the accessory screws into the holes on the side of CT-6700 digital engine tachometer.

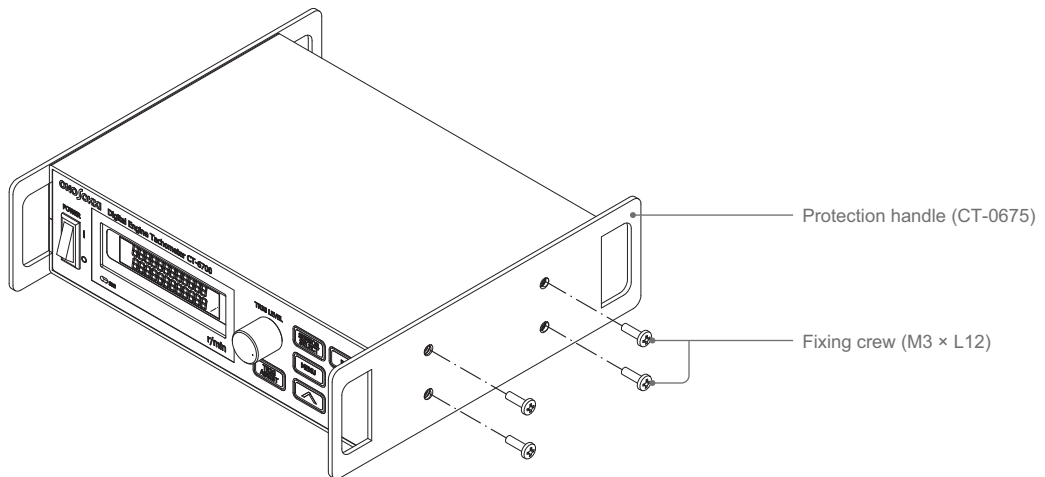

- 2 Mount the CT-6700 digital engine tachometer to the passenger seat of the vehicle. Connect the cable with hooks to the CT-0675 protection handle and pull the four corners of the sheet as illustrated below, so that the unit does not accidentally move.

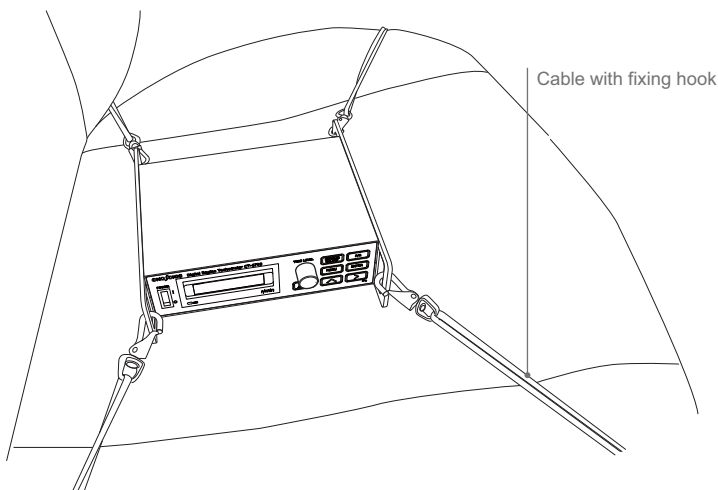

- To conduct a measurement on the public roads with the vehicle mounted the CT-6700 digital engine tachometer, you may require permission from the local police or authorities concerned. For details, contact your local police station.



## ■ Mounting on a Panel

- You need to purchase the optional CT-0673 panel mount fitting to fix the CT-6700 digital engine tachometer to a panel such as the control panel.  
If you are replacing the already mounted CT-6520B with CT-6700, purchase the optional CT-0674 panel mount fitting.  
For details on the optional accessories, contact the nearest Ono Sokki sales office or the distributor where you purchased the product.

Following the figure and the procedure below, attach the CT-6700 digital engine tachometer to the panel.

- Attach the optional CT-0673 panel mount fitting to the CT-6700 digital engine tachometer. Attach the optional CT-0673 panel mount fitting by driving the accessory screws into the holes on the side of CT-6700 digital engine tachometer.

The CT-0673 panel mount fitting has three holes. Align them with the panel and find the best position to attach the fitting.

Use the screws (M3 × L12) that come with the product to secure the CT-0673 panel mount fitting. Do not use long screws since they could damage the internal parts. Do not drive the screws deeper than 10 mm.
- Insert the CT-6700 digital engine tachometer to the mounting hole on the panel. Insert the main unit of the CT-6700 digital engine tachometer to the mounting hole on the panel from the rear panel.
- Fix the CT-6700 digital engine tachometer to on the panel. Secure the CT-6700 digital engine tachometer and the panel to the CT-0673 panel mount fitting with the accessory panel mounting screws (M5).

The tightening torque to be applied to the panel mounting screws (M5) is 0.49 to 0.69 N·m.

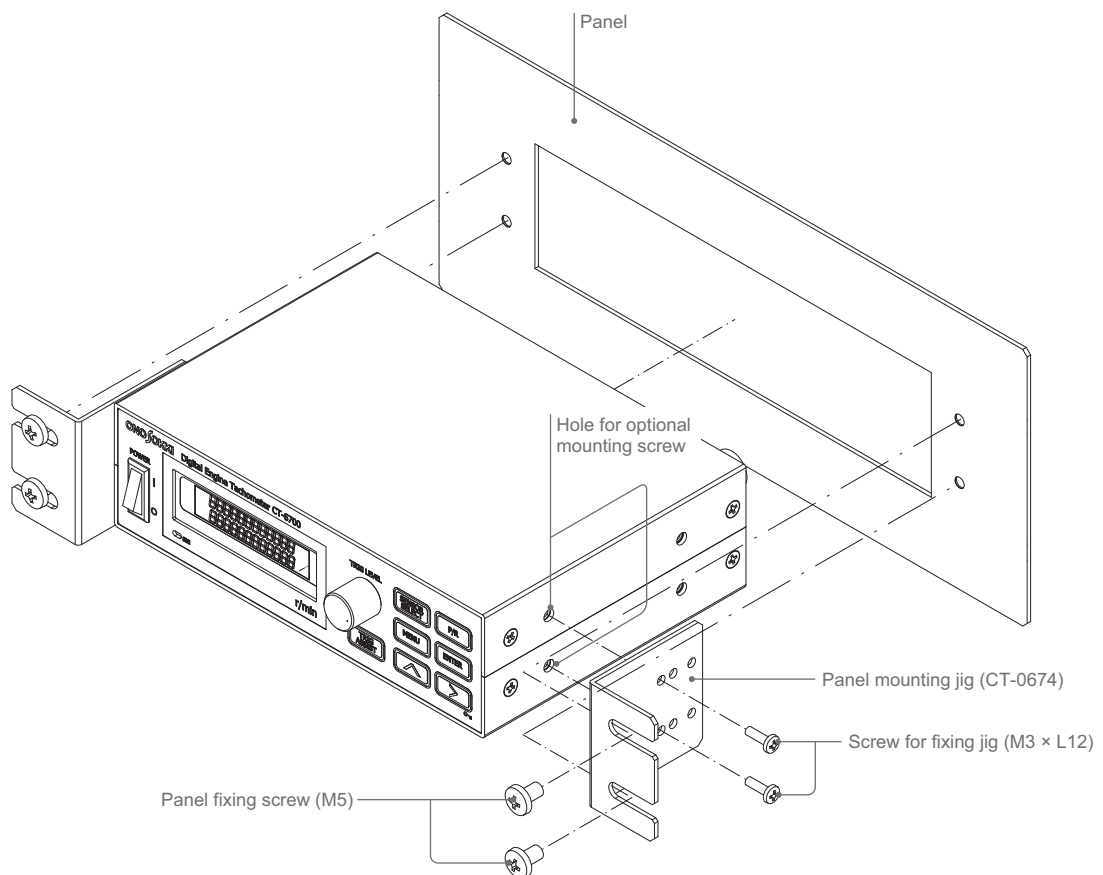

## 2.2 Connecting Power Supply

Connect the power.

The power can be supplied to the CT-6700 digital engine tachometer in either of two ways: AD adapter or battery.

### ■ Using AC Adapter



- Use the AC adapter or power cable that comes with the CT-6700 digital engine tachometer only. If you use the AC adapter or power cable other than specified may cause a fire or an electric shock voltage.
- Always use the AC adapter within the specified range of rated voltage. The supply voltage of the AC adapter that comes with the CT-6700 digital engine tachometer is 100 to 240 VAC (50/60 Hz). Otherwise, it could cause a fire or electric shock.
- The withstand voltage for the power cable of the AC adapter is 125 V. Do not use any voltage over 125 V. If you need to use at a voltage over 125 V, contact the nearest Ono Sokki sales office or the distributor where you purchased the product first.

Connect the AC adapter that comes with the product as follows:

- 1 Make sure that the power switch of the CT-6700 digital engine tachometer is turned off (○).
- 2 Connect the AC adapter.  
Insert the plug of the AC adapter securely into the bottom of the DC power input terminal (DC INPUT) located on the rear panel of the CT-6700 digital engine tachometer.  
After connecting the AC power cable to the AC adapter, insert the power plug of the power cable into the 3-wire AC outlet (100 to 240 VAC).

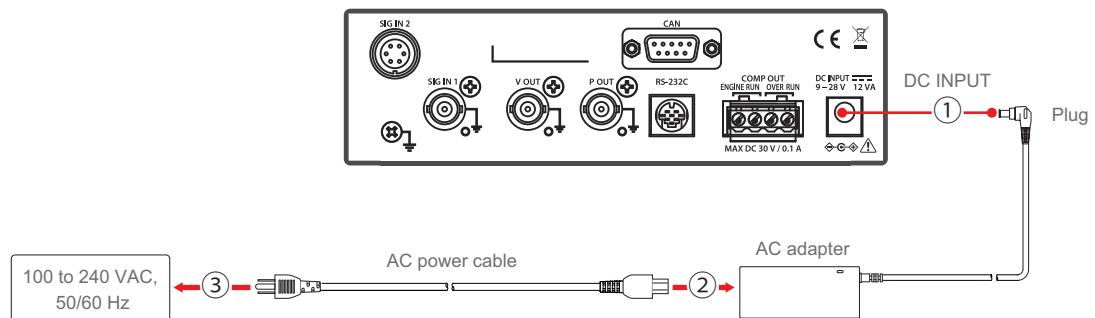

### ■ Using the Car Battery



- Depending on the position of the car battery, it could not be used. Before using the car battery, refer to the relevant vehicle instruction manual. While using the battery, never leave the vehicle unattended to avoid accidents.
- Be sure that the power supply polarity (⊕ and ⊖) is correct. The wrong polarity will damage the internal circuit.
- When cabling, be careful so that the cable is not caught in the fan belt or pulley.
- The product is supported for the 12 to 24 V. Do not use any voltage lower than 12 V or over 24 V. If you need to use the voltage outside this range, contact the nearest Ono Sokki sales office or the distributor where you purchased the product.

The battery can be connected to the power supply in two ways: direct connection to the battery or the connection via the cigarette lighter socket.

#### ● Direct connection to battery



- The LC-0082 battery power cable is optional. For details on the purchase, contact the nearest Ono Sokki sales office or the distributor where you purchased the product.

If the power is supplied from a battery, use the optional LC-0082 battery power cable. Connect the battery to the power supply as follows:

- 1** Make sure that the power switch of the CT-6700 digital engine tachometer is turned off (○).
- 2** Connect the battery. Insert the plug of LC-0082 cigar lighter socket securely into the bottom of the DC power input terminal (DC INPUT) located on the rear panel of the CT-6700 digital engine tachometer. Then, connect the black side of the LC-0082 battery power cable to ⊖, and the red side of the LC-0082 battery power cable to ⊕, respectively.

● **Connection via cigar lighter socket**



- The power cable for the LC-0865 cigar lighter socket is optional. For details on the purchase, contact the nearest Ono Sokki sales office or the distributor where you purchased the product.

If the power is supplied via the cigar lighter socket, purchase the optional power cable for the LC-0865 cigar lighter socket.

Connection via the cigar lighter socket as follows:

- 1** Make sure that the power switch of the CT-6700 digital engine tachometer is turned off (○).
- 2** Connect the cable to the cigar lighter socket. Insert the plug of LC-0865 cigar lighter socket securely into the bottom of the DC power input terminal (DC INPUT) located on the rear panel of the CT-6700 digital engine tachometer. Then, firmly insert and secure the cigar socket plug of the LC-0865 cigar lighter socket on the power cable side into the cigar lighter socket.

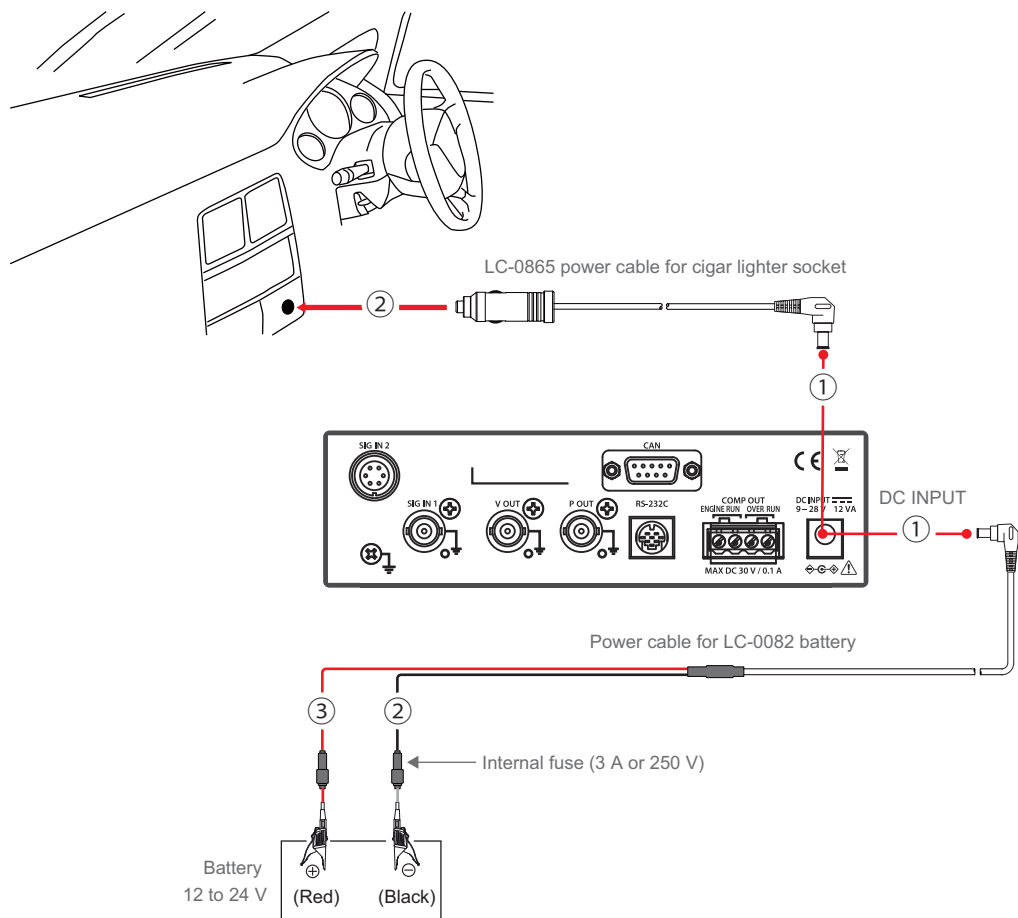

## 2.3 Installing and Connecting Sensors

After connecting the power supply to the CT-6700 digital engine tachometer, install relevant sensors onto the measurement object, referring to the following installation example.

After installing the sensors, connect them to the CT-6700 digital engine tachometer as described in “Connecting a Sensor to CT-6700” on page 31.

Measurement object	Reference
Detecting with gasoline engine (Distributor type)	Page 28
Detecting with gasoline engine (Direct ignition)	Page 28
Detecting with EV/HEV motor or alternator	Page 29
Detecting with engine vibration	Page 29
Detecting with gears attached to the rotating body	Page 30
Detecting with reflectors on the rotating body	Page 30
Detecting with signals between the crank angle sensor and ECU	Page 30



- The attaching method to the measurement object varies depending on the sensor. There might be other attaching methods depending on the measurement objects. For details, refer to the instruction manual of the relevant sensor, or contact the nearest Ono Sokki sales office or the distributor where you purchased the product.

### ■ Detecting with Gasoline Engine (Distributor Type)

Install the P-292/IP-3000A ignition pulse detector on the primary side to the gasoline engine of the distributor type.

Attach the P-296/IP-3100 ignition pulse detector on the secondary side.

The following figure shows the installation example with the ignition pulse sensor attached to the four-cylinder gasoline engine.

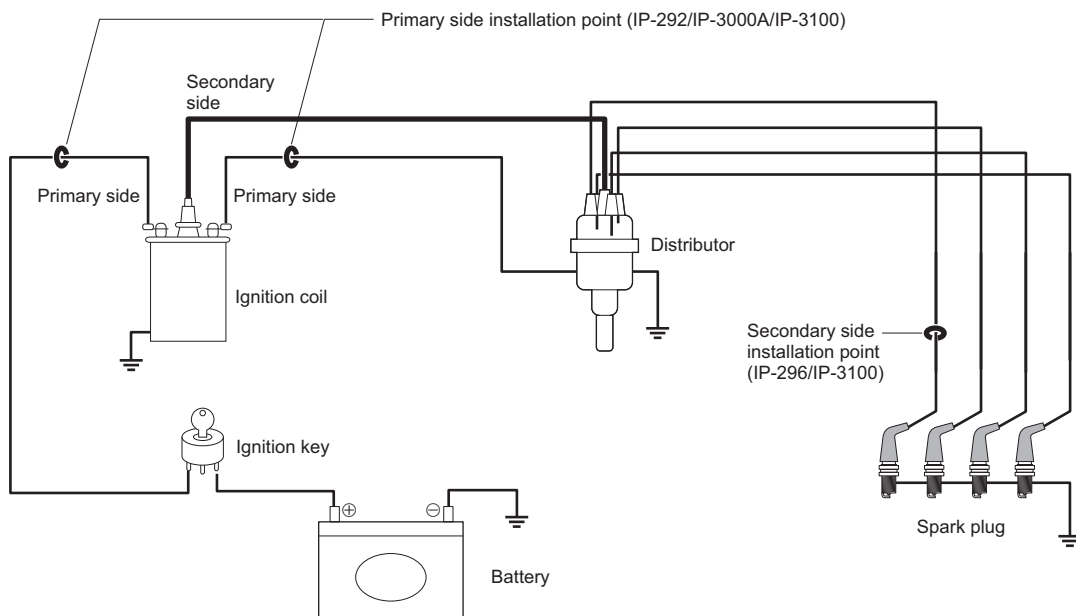

### ■ Detecting with Gasoline Engine (Direct Ignition)

To attach to the direct ignition gasoline engine, attach the IP-3000A ignition pulse detector to the power cable from the connector of the direct ignition.

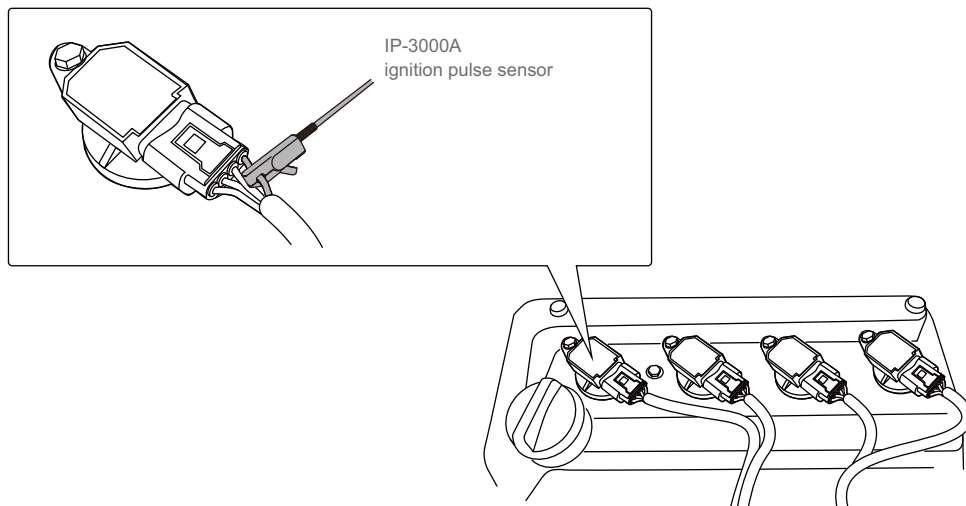

### ■ Detecting with EV/HEV Motor or Alternator

Attach the OM-1200/1500 Motor/gasoline engine RPM detector to the motor (EV/HEV) or the engine alternator installed on a electric vehicle or hybrid electric vehicle.

#### ● Measuring with the motor (EV/HEV)

When attaching the detector to the motor (EV/HEV), mount it perpendicular to the rotation axis of the motor, so it does not stick out of the motor.

Change the number of pulse setting depending on the number of polarity of the motor.

#### ● Measuring with the alternator

When attaching the sensor to the engine alternator, mount the long side of the sensor in the circumferential direction of the alternator.

In this case, the alternator rotation and the engine rotation need to be synchronized. Thus, if the belt connecting the alternator and the engine is loose, it could cause some measurement errors.

For details on the setup, refer to "Setting Factor Conditions (2: FACTOR)" on page 50.

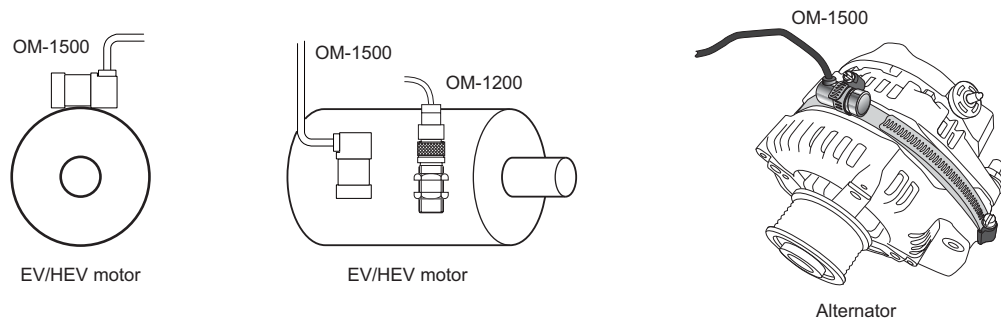

- Depending on the types of the motor (EV/HEV) or engine alternator, detection might not be reliable. Find where the rotation speed can be correctly measured by testing the position and direction of the sensor.

### ■ Detecting with Engine Vibration

To measure the rotation speed with the gasoline/diesel engine vibration, attach the VP-202/1200 Engine vibration detector to the engine to be measured. Measurement might not be possible with a engine with six cylinders.

Attach the VP-202/1200 Engine vibration detector to the horizontal position of the frame of the gasoline/diesel engine as illustrated below.

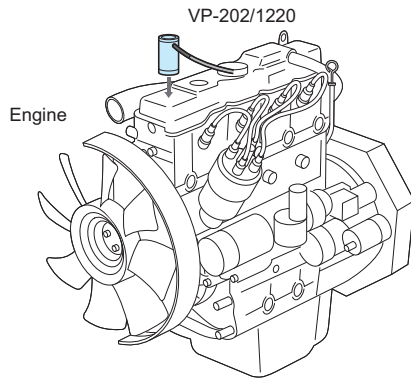

### ■ Detecting with Gears Attached to the Rotating Body

The following illustrates the installation example of the sensor to be measured with the gear attached to the rotating body.

Attach the ferric gear to the engine or standard rotating body to be measured.

Then, place it adjacent to the detection gear with the MP-900/9000 series electromagnetic detector.

When the attached gear rotates, the frequency signal is output from the detector proportional to the rotation speed.

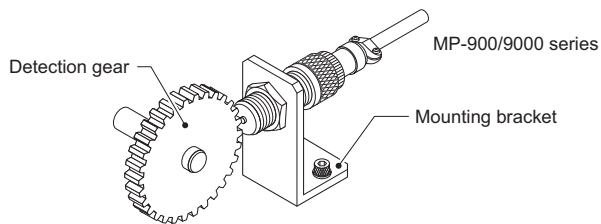

### ■ Detecting with Reflector on the Rotating Body

The following illustrates the installation example of the sensor to measure with the reflector on the rotating body.

Attach the reflector to a normal rotating body on an engine or a motor.

Then, aim the light (red visible light) of the LG-9200/930 Optical detector at the reflector.

The signal proportional to the rotation speed is output by detecting the reflected light.

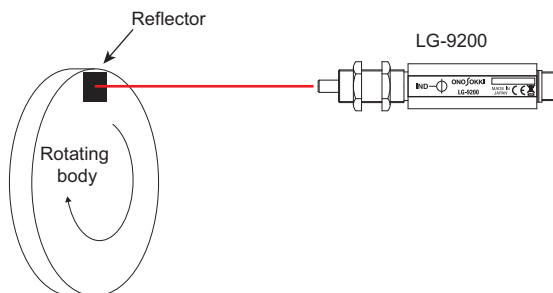

### ■ Detecting with Signals between the Crank Angle Sensor and ECU

If you mount the optional CT-0672 ECU crank angle signal input, it is possible to measure the rotation speed from the crank angle signal.

Branch the cable connecting the crank angle sensor and ECU as follows, and input the signal to the CT-6700 digital engine tachometer.



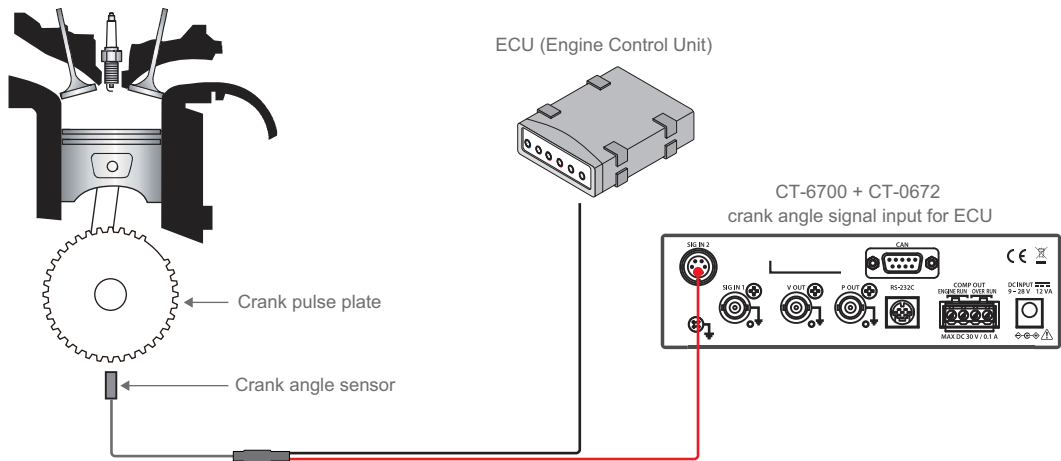

- The CT-0672 ECU crank angle signal input is an option. For the purchase, contact the nearest Ono Sokki sales office or the distributor where you purchased the product.
- It is the user's responsibility to pull out the signal line from the ECU or branch the cable properly. Ono Sokki shall not be held liable for any consequences arising from any faulty modification or implementation.

### ● Branching a cable

There are two different branching methods: the hole method or the pickup coil method. Branch the cable referring to the following figure.

Method	Waveform image	Circuit
Hole method		
Pickup coil method		

### ■ Connecting a Sensor to CT-6700

Connect the cable of the sensor on the measurement object, to the sensor connector of SIG IN 1 or SIG IN 2 located on the rear panel of the CT-6700 digital engine tachometer.



- For details on the cabling to connect the CT-6700 digital engine tachometer and the sensor, refer to our website (<https://www.onosokki.co.jp/English/english.htm>) or brochure of the sensors, or contact the nearest Ono Sokki sales office or the distributor where you purchased the product.

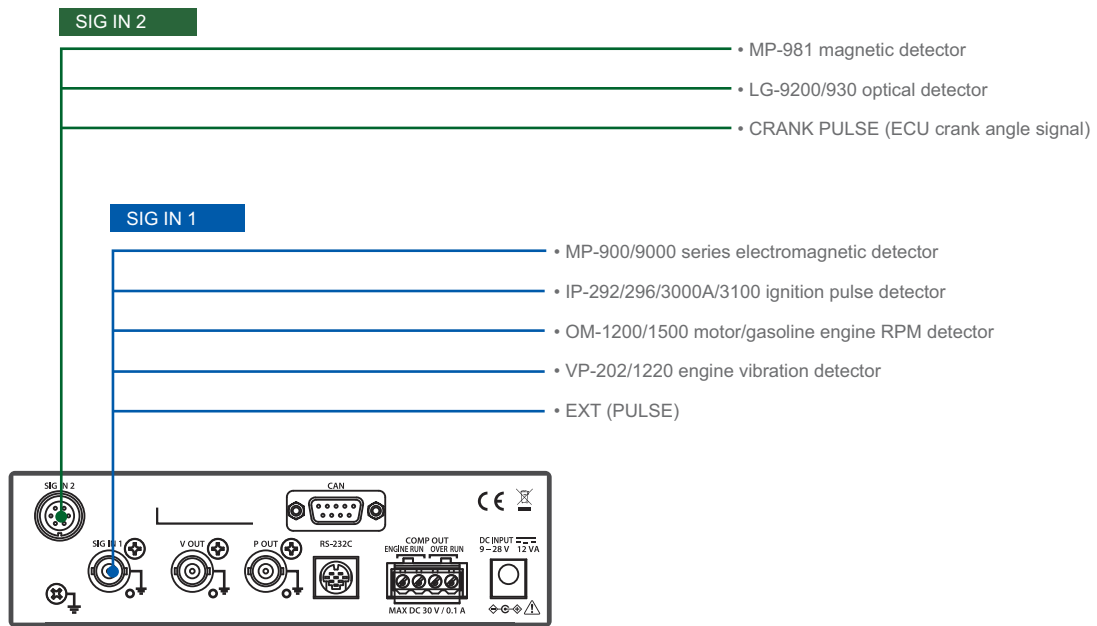

● **SIG IN 1 connector pin assignment**

Applicable connector for SIG IN 1 is the BNC plug. The pin assignment is shown below.

● **SIG IN 2 connector pin assignment**

The applicable connector for SIG IN 2 is the screw-coupling miniature circular connector (Tajimi Electronics: R03-PB6M). The pin assignment is shown below.

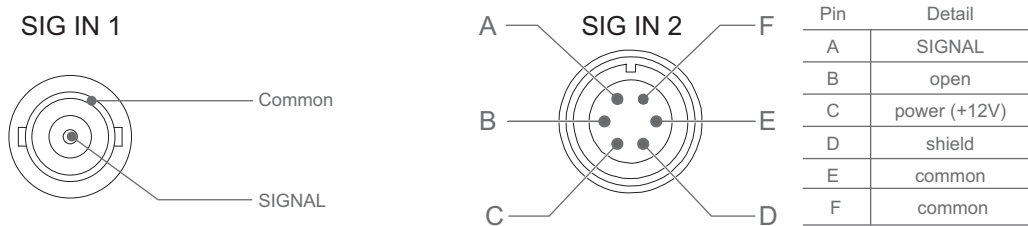

- The common terminal for SIG IN 2 is isolated from the common terminal of SIG IN 1/V OUT/P OUT and the cabinet.

## 2.4 Connecting Peripheral Units

After connecting the power supply and installing the sensor, connect peripheral units.

This section describes V-OUT (voltage output connector), P-OUT (pulse output connector) and COMP OUT (comparator contact output terminal) and the connectible peripheral units.

For detail on the RS-232C communication connector and the CAN communication connector (optional CT-0671 CAN output) and the connectible peripheral units, refer to "Interface Reference" on page 63.



- Before connecting peripheral units to the CT-6700 digital engine tachometer, be sure to read the instruction manuals for the relevant units to be connected.
- For details of the measuring instruments compatible with the CT-6700 digital engine tachometer, contact the nearest Ono Sokki sales office or the distributor where you purchased the product.

### ■ Connection to V-OUT (Voltage Output Connector)

The Ono Sokki's DR-7100 portable data recorder for acoustics and vibration is connected to the V-OUT (voltage output connector).

For the recommended circuit shown below, a filter suitable to the environment should be prepared. The same circuit as this one is integrated to the DR-7100 portable data recorder for acoustics and vibration, which facilitates the setup. For details of the V-OUT setup, refer to "2.5 Setting Output Voltage Conditions (3: V-OUT)" on page 52.



- To comply with the EMC Directive, the BNC cable shall be 10 meters or shorter.

#### ● Recommended circuit for output connector

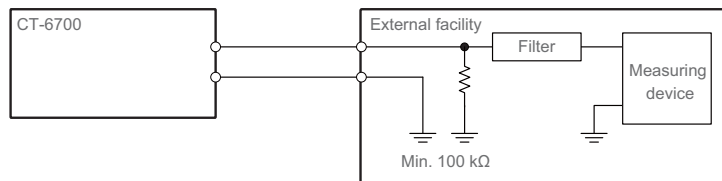

### ■ Connection to P-OUT (Pulse Output Connector)

The Ono Sokki's CF-9000 series FFT analyzer is connected to the P-OUT (pulse output connector).

The same circuit as the following recommended circuit is integrated to the CF-9000 series FFT analyzer, which facilitates the setup. For details on the P-OUT setup, refer to "2.4 Setting Pulse Output Conditions (2: P-OUT)" on page 52.



- To comply with the EMC Directive, the BNC cable shall be 10 meters or shorter.

#### ● Recommended circuit for pulse connector

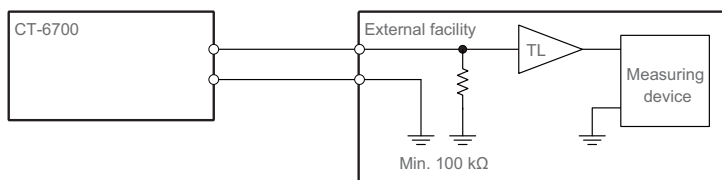

### ■ Connecting to COMP OUT (Comparator Contact Output Terminal)

The COMP OUT (comparator contact output terminal) is used to connect a PLC (Programmable Logic Controller). For the setup of COMP OUT, refer to "2.6 Setting Comparator Output Conditions (4: COMP-OUT)" on page 53.



- To comply with the EMC Directive, the cable shall be 3 meters or shorter.

#### ● Recommended circuit for comparator contact output terminal

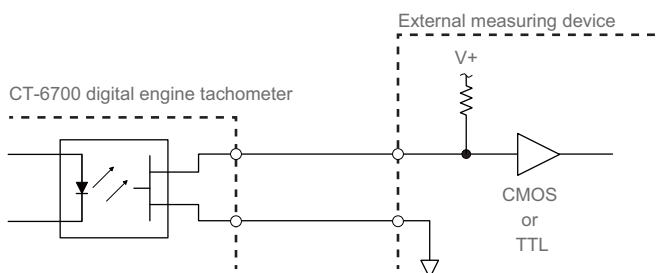



- Connection to the comparator contact output terminal  
Secure the cable from the equipment to be connected to the terminal block, then attach it to the COMP OUT (comparator contact output terminal) as illustrated below. Use an AWG24-12 cable.

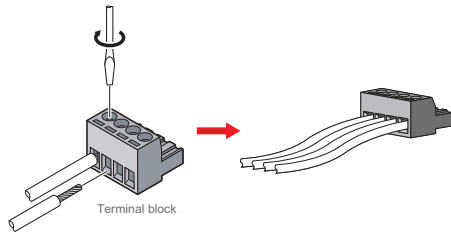

- The V+ and the inflowing current should be set within the rated value range.

## 2.5 Powering Up

After installing the CT-6700 digital engine tachometer and completing all connections, turn it on in the following procedure.

- 1** Power up the peripheral devices.
- 2** Turn the power switch of the CT-6700 digital engine tachometer from ON (|) to OFF (○). When turned on, it starts in the measurement mode and measured values are shown on the display panel. 0 (zero) is shown here because no measurement conditions are selected. For details on the measurement mode, refer to “3. Names of Screens and Display Items” on page 15.
- 3** Turn on the engine or the rotating body to be measured.



## 2.6 Setting General Conditions in the Sensor Select Mode and Pulse Setup Mode

General conditions for the CT-6700 digital engine tachometer can be set by select the sensor in the sensor select mode first, and then, the pulse count in the pulse setup mode.

Other conditions should be set depending on your usage and purposes.

### ■ Selecting a Sensor in the Sensor Select Mode (SENSOR SELECT)

This section describes the procedure for selecting the sensor by taking the IP-296 selecting (confirmation) procedure as an example.

- 1** Press the SENSOR SELECT switch to enter the sensor select mode (SENSOR SELECT).
- 2** Change the type of sensor.  
Every time you press the upward (^) switch, the mode changes in the following order: 0: EXT (PULSE) → 1: IP292 → 2: IP296 → 3: IP3000/3100 → 4: VP202/1220 → 5: OM1200/1500 → 6: MP900/9000 → 7: LG/MP981 → 8: CRANK PULSE → 0: EXT (PULSE) → ...
- 3** Select (confirm) IP296.  
If you press the ENTER switch after selecting 2: IP296, the sensor displayed is confirmed as IP296 and the system returns to the measurement mode.  
If you press the MENU switch, the confirmation of the sensor is canceled and the system returns to the measurement mode.
- 4** Make sure the measured value is displayed.  
After completing the setting for the connected sensor, the measured value is displayed.

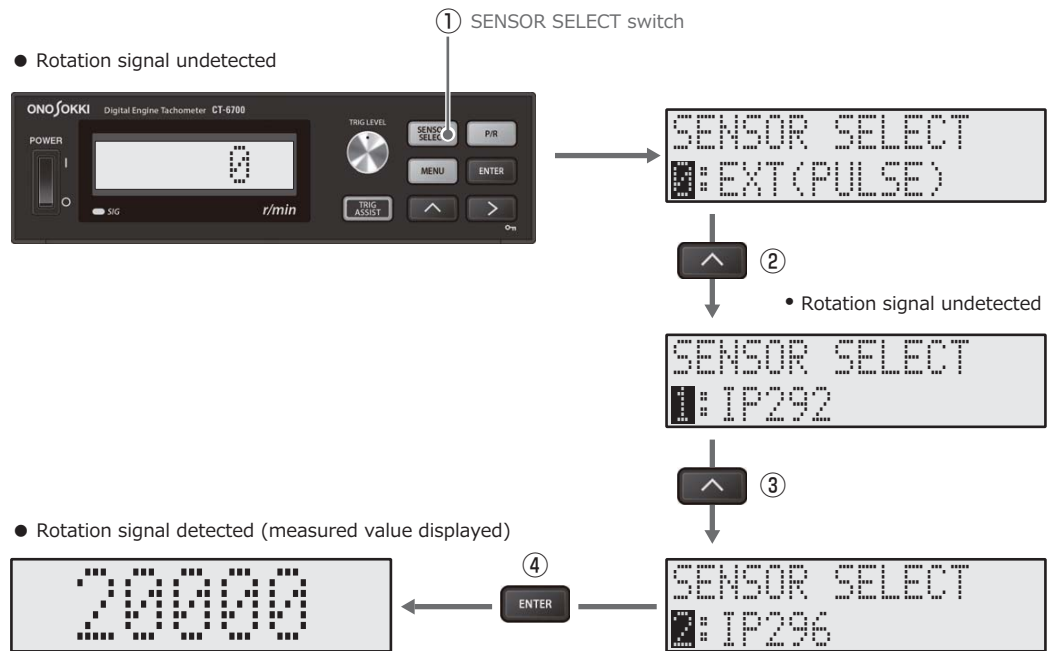

- If measured values are not displayed in the CT-6700 digital engine tachometer, check the connection by referring to “2.3 Installing and Connecting Sensors” on page 28.  
If it is connected properly and the peripheral units are operating normally, the CT-6700 digital engine tachometer might be faulty. In such case, stop using it immediately and contact the nearest Ono Sokki sales office or the distributor where you purchased the product.

### ■ Setting Pulse Count in Pulse Setup Mode

After setting the sensor, set the value of pulses per rotation (P/R).

The following describes the procedure for setting the number of pulses in the pulse setup mode by taking the measurement of a standard two-cycle engine using IP-296 as an example.

- 1** Press the P/R switch to enter the pulse setup mode (P/R).  
The default setting is 0.5 (0000.5).
- 2** Change the number of pulse to 1.0 (0001.0).  
Press the right arrow (>) switch to select (highlight) the digit to set, and change the value (0 to 9) by pressing the upward (^) switch.  
Change the pulse count to 1.0 (0001.0) by repeating the above operations.
- 3** Confirm the pulse count to be 1.0.  
If you press the ENTER switch, the pulse count is set to 1.0 (0001.0) and the system returns to the measurement mode.

If you press the MENU switch, the confirmation of the sensor is canceled and the system returns to the measurement mode.

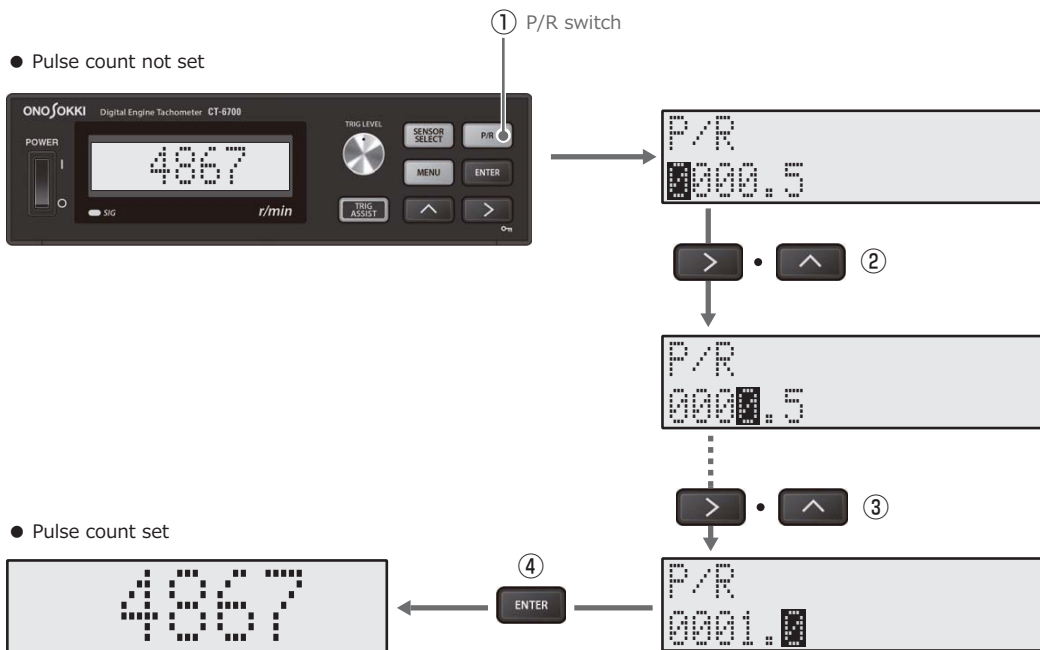

● List of preset pulse counts for gasoline engines

The following table is the list of pulse counts to be set for measuring the gasoline engine speed. Note that the value might differ depending on the ignition system of the engine.

For details of pulse counts other than the gasoline engine, refer to “1.11 Pulse Count per Revolution (P/R) and r/min Range” on page 79.

□ Distributor type

Detection of primary side	Four-cycle									
	Number of cylinders	1	2	3	4	5	6	8	10	12
	P/R	0.5	1	1.5	2	2.1	3	4	5	6
	Two-cycle									
	P/R	1	2	3	4					
Detection of secondary side	Four-cycle									
	P/R	0.5 (regardless of the number of cylinders)								
	Two-cycle									
P/R	0.5 (regardless of the number of cylinders)									

□ Direct ignition method

There is no difference between the primary side and the secondary side detection in the direct ignition method.

Four-cycle	
P/R	0.5 (regardless of the number of cylinders)
Two-cycle	
P/R	1.0 (regardless of the number of cylinders)

■ Setting Other Conditions

After setting the sensor and the pulse count, set other conditions depending on your usage or purpose in the menu mode. You can enter the menu mode by pressing the MENU button. For details, refer to “2. Menu Reference” on page 48.

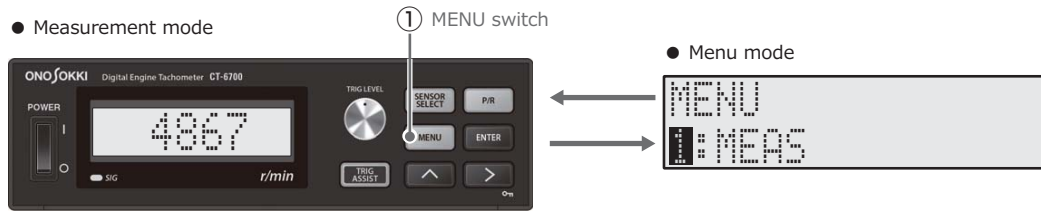

## 2.7 Adjusting Trigger Level and Checking Operation

After setting the general conditions, adjust the trigger level and check the operation.

This section describes the procedure for adjusting the trigger level and checking the operation with the IP-292/296 and IP-3000A/3100 ignition pulse detector using the ignition signal.

For other signals (a leakage magnetic flux detected with an engine vibration or an electromagnetic induction of the EV/HEV motor), refer to the manuals relevant to each sensor.

### ■ Adjusting Trigger Level

The following is the waveform example of the detected ignition signal.

An ignition signal can be affected by inductions and noises caused by ignition of other cylinders besides the ignition signal to be measured.

If the trigger level is set too high (e.g. level C), the ignition signal that needs to be detected might be overlooked.

If the trigger level is set too low (e.g. level A), the unnecessary signals such as inductions and noises from the ignition of other cylinders are also detected.

The trigger level should be set to the suitable level (e.g. level B) to detect only the necessary ignition signals.

There are two methods to adjust the trigger level: automatic adjustment with the trigger assist mode, and manual adjustment with the trigger level adjustment dial.

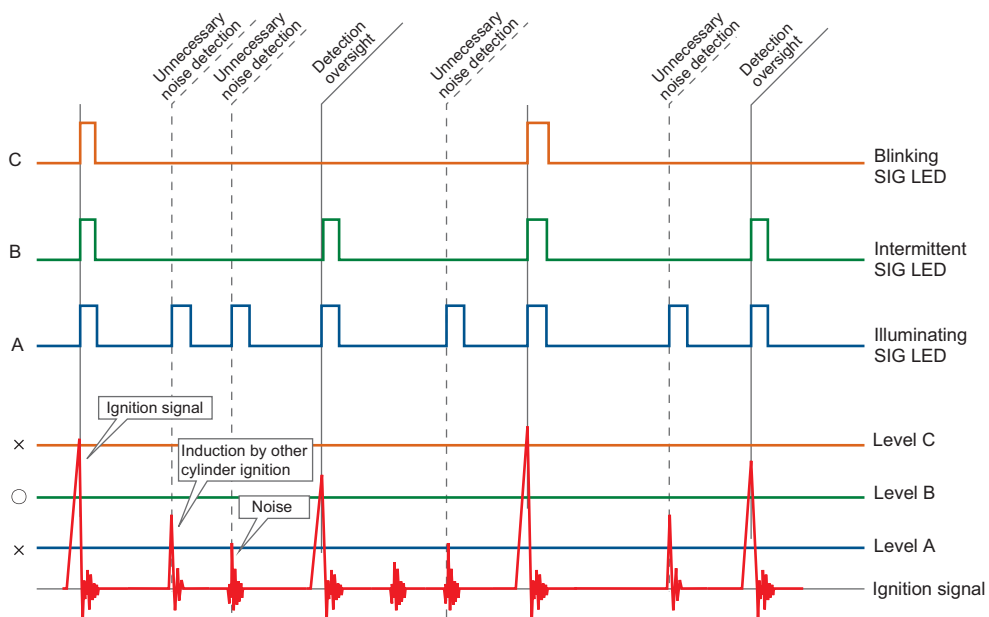

### ■ Procedure for Automatic Trigger Level Adjustment with the Trigger Assist Mode

Usually, set the trigger level to be adjusted automatically in the trigger assist mode.

- 1 Start the engine idling.
- 2 Switch to the trigger assist mode.  
When you press the TRIG ASSIST button, the system enters the trigger assist mode.
- 3 Execute the trigger assist.  
Press the upward (^) switch and change from the 0: NO of TRIG ASSIST? to 1: YES.  
When you press the ENTER switch, the automatic adjustment of the trigger level starts, and the "PLEASE WAIT..." message is shown.  
Usually the automatic adjustment will be completed in 2 or 3 seconds (at most 8 seconds).  
When it completes successfully, "COMPLETE" message is shown.  
The automatic trigger adjustment is completed when you press the ENTER switch.  
If it is not for some reason, the "ERROR" message is shown. Press the ENTER switch and repeat the procedure from step 1 in order.  
If you repeat the procedure for several times and the ERROR message persists, change the gain condition setting. For details, refer to "Setting Gain Conditions (1: GAIN)" on page 50.
- 4 Check the operation of trigger level.  
Make sure that the measurements are reliable at different rotation speeds.  
If the illuminating or blinking of the SIG (signal indicator) is not stable, readjust the trigger level in the procedure starting from 1.

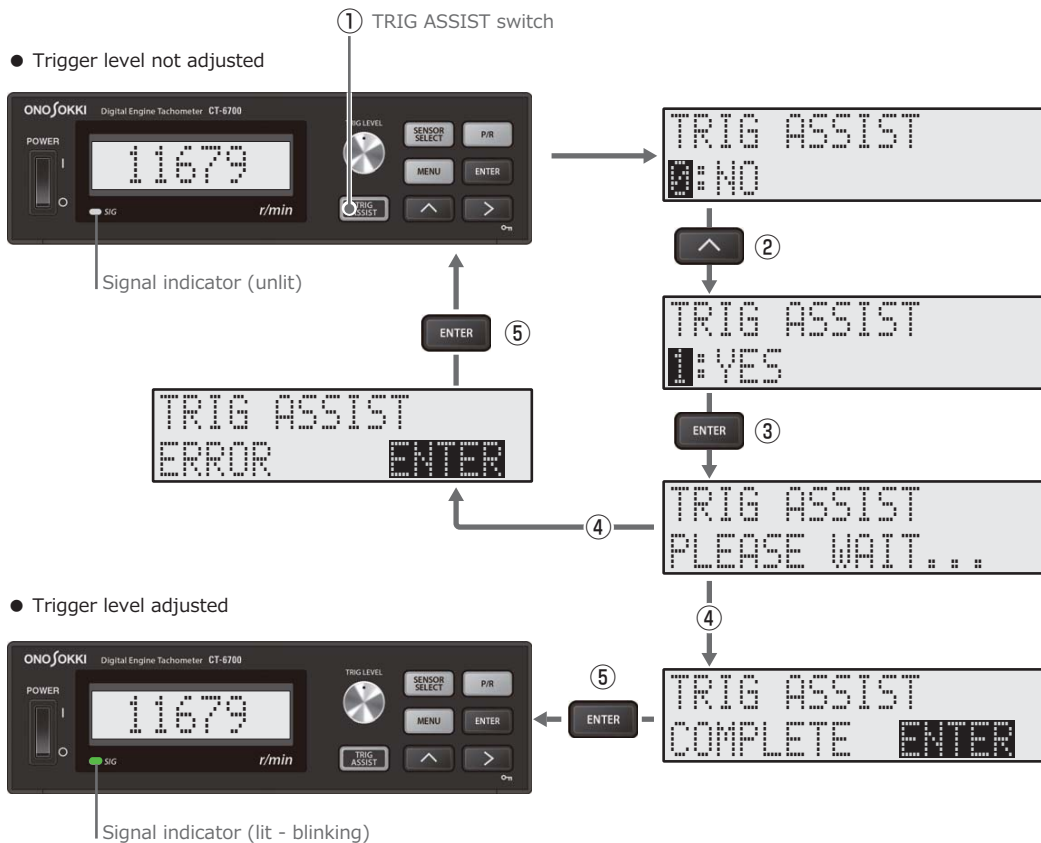

### ■ Manual Trigger Level Adjustment

If the adjustment of trigger level is not successful in the trigger assist mode for some reasons, use the manual procedure below to adjust the trigger level.



- 1** Turn the trigger level adjustment dial to the right/left to enter the trigger level setting mode (TRIG).  
In the trigger level setup mode, the measured value is shown in the upper line (MEAS:) and the trigger level value is shown in the lower line (TRIG:).
- 2** Adjust the trigger level between blinking and illuminating of the SIG (signal indicator).  
You can decrease or increase the selected digit of the trigger level by turning the trigger level adjustment dial (clockwise: increase; counter-clockwise: decrease).  
Press the right arrow (>) switch to select (highlighten) the digit to set, and change the value (0 to 9) by pressing the upward (^) switch.  
The SIG (signal indicator) blinks or goes on if the signal level from the sensor matches to the trigger level. Increase/decrease the trigger level by turning the trigger level adjustment dial to the right/left after pressing the right arrow (>) switch and select the lowest digit to set (the first decimal point, in this example).  
Adjust the trigger level between blinking and illuminating of the SIG (signal indicator) and press the ENTER switch. The system returns to the measurement mode. If you press the MENU switch, the confirmation of the sensor is canceled and the system returns to the measurement mode.
- 3** Check the operation of trigger level.  
Make sure that the measurements are reliable at different rotation speeds.  
If the illuminating or blinking of the SIG (signal indicator) is not stable, readjust the trigger level in the procedure starting from **1**.

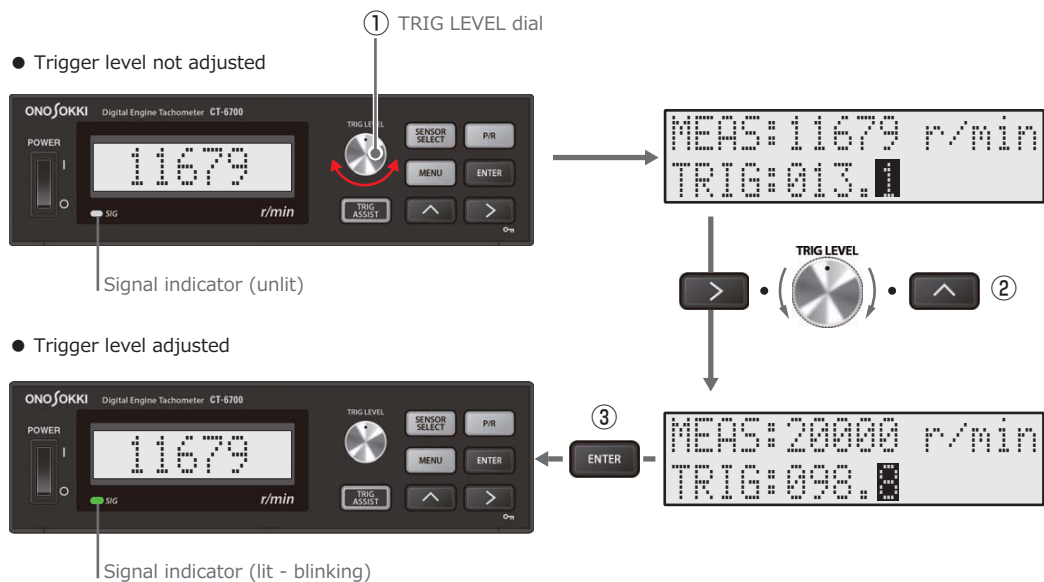

## 2.8 Starting and Finishing Measurement

### Starting Measurement

Start measurement in the following procedure after installation, connection and condition setting are all completed.

- 1** Activate the key protection.  
Activate the key protection to prevent the accidental change of the trigger level value or other conditions by erroneous operations of switches and dials.

To activate the key protection, press the right arrow (>) switch for more than 1 second. The key protect icon (🔑) appears on the lower right in the measurement mode. With the key protection activated, every switch and dial except the right arrow (>) switch is disabled. To deactivate the key protection, press the right arrow (>) switch for more than 1 second again.

- 2 Start measurement operation.
  - Key protection-enabled screen

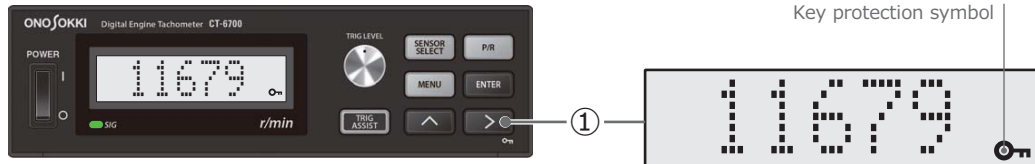

## Finishing Measurement

After finishing measurement, complete the measurement in the following procedure.

- 1 Stop the equipment to be measured such as the engine and the rotating body. Turn off the engine or rotating body to be measured as necessary.
- 2 Turn off the peripheral devices.
- 3 Turn off the CT-6700 digital engine tachometer. Turn the power switch of the CT-6700 digital engine tachometer from ON (|) to OFF (○).

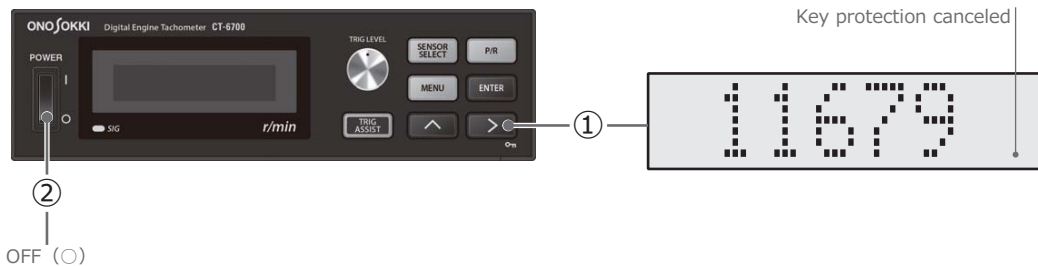

## 2.9 Removing and Storing Equipment

After completing measurement, remove and store the equipment in the following procedure.

### (1) Disconnecting the Power Supply

Disconnect the CT-6700 digital engine tachometer from the power supply in the reverse order of the procedure described in "2.2 Connecting Power Supply" on page 26.

### (2) Removing the Sensor

First, remove the sensor installed to be measured.

Next, disconnect the CT-6700 digital engine tachometer from the power supply.

Store the removed sensors and cables in the temperature and humidity range specified in the relevant product manual.

### (3) Removing Peripheral Devices

Disconnect the peripheral measuring devices from the CT-6700 digital engine tachometer.

Store the removed peripheral devices and cables in the temperature and humidity range specified in the relevant product manual.

# Chapter 3

## Mode and Menu Reference

1. Menu Mode Reference 42

2. Menu Reference 48

# 1. Menu Mode Reference

## 1.1 Overview of Menu Mode



- When you change the condition setting in the menu mode, wait for over 3 seconds before turning off the power switch (○).  
If you turn off the power switch within 3 seconds after changing the conditions, they will not be validated.

### Mode Controllers

The following dials or switches toggles between the measurement mode and menu mode to set conditions.

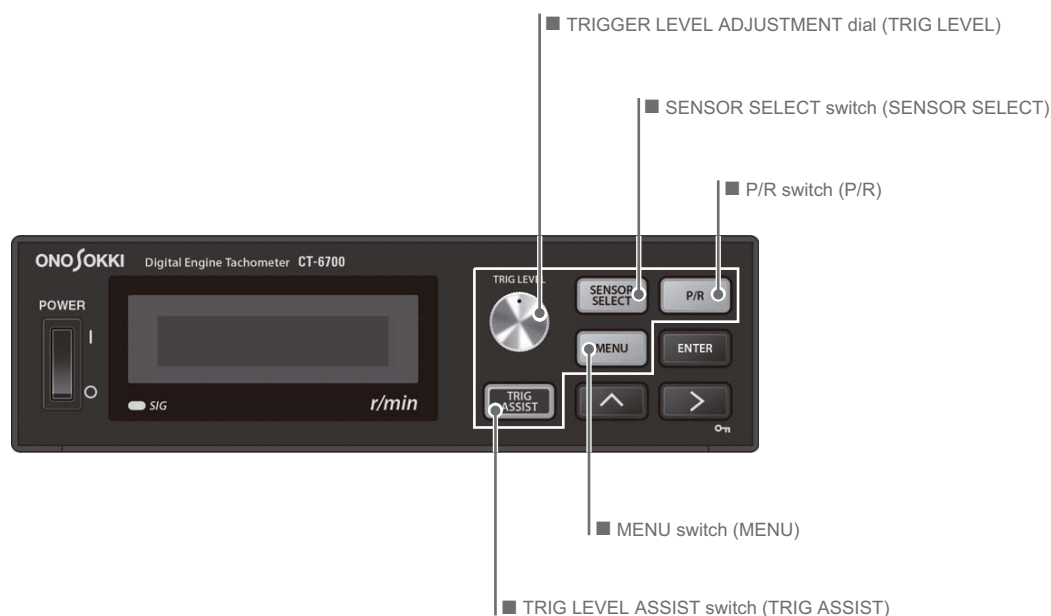

Operation dial or switch		Menu mode	Reference
TRIGGER LEVEL ADJUSTMENT dial	TRIG LEVEL	Trigger level setup mode (TRIG)	Page 45
SENSOR SELECT switch	SENSOR SELECT	Select select mode (SENSOR SELECT)	Page 45
P/R switch	P/R	pulse setup mode (P/R)	Page 45
TRIG LEVEL ASSIST switch	TRIG ASSIST	Trigger assist mode (TRIG ASSIST) ECU crank pulse calibration mode (CRANK PULSE CAL)	Page 46 Page 46
MENU switch	MENU	Menu mode	Page 48



- The ECU crank pulse calibration mode (CRANK PULSE CAL) is the menu mode available when the optional CT-0672 ECU crank pulse input is installed.
- For details on the optional accessories, contact the nearest Ono Sokki sales office or the distributor where you purchased the product.

### Setting Operation for Conditions and Values in Menu Mode

The five types of dials and switches are available to select items or change values in the menu mode: the TRIGGER LEVEL ADJUSTMENT dial, the MENU switch, the RIGHT ARROW (>) switch, the UPWARD (^) switch and the ENTER switch.

This section describes the operation method of the TRIGGER LEVEL ADJUSTMENT dial and switches taking the condition setting operations as an example.

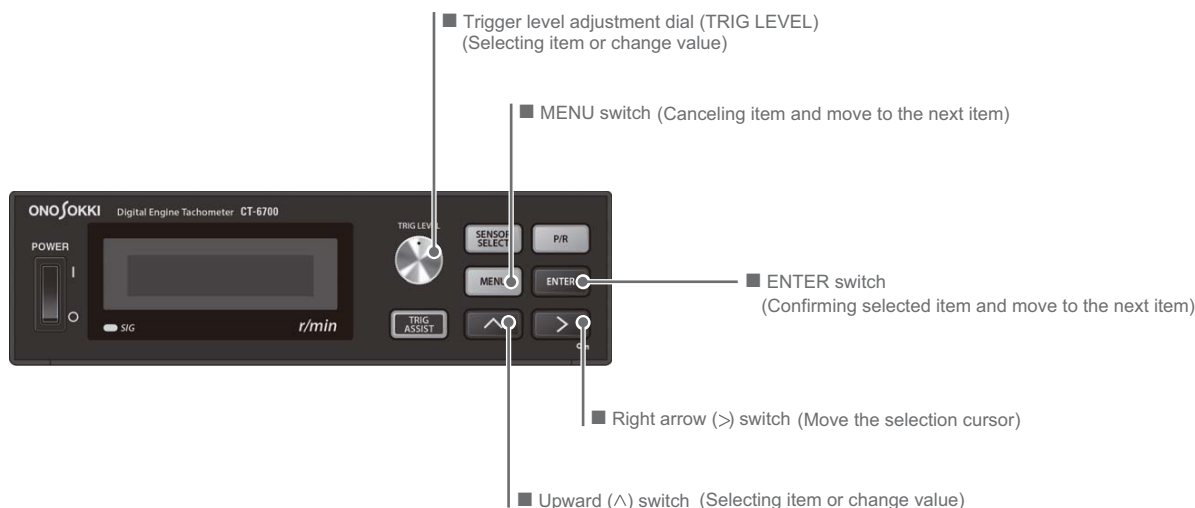

● **Change setting condition and confirmation operation**

This section describes how to select (and confirm) the desired item out of several items taking the procedure to set (and confirm) the sensor to IP296 as an example.

**1** Press the SENSOR SELECT switch to select the sensor (SENSOR SELECT) in the direct menu mode.

**2** Change the type of sensor.  
 Every time you press the UPWARD (^) switch, the mode changes in the following order: 0: EXT (PULSE) → 1: IP292 → 2: IP296 → 3: IP3000/3100 → 4: VP202/1220 → 5: OM1200/1500 → 6: MP900/9000 → 7: LG/MP981 → 8: CRANK PULSE → 0: EXT (PULSE) → ...

If you turn the TRIGGER LEVEL ADJUSTMENT dial, the sensor type toggles between ascending order (0: EXT (PULSE) → 1: IP292 → ...) and descending order (8: CRANK PULSE → 7: LG/MP981 → ...).

**3** Set (and confirm) the sensor as IP296.  
 If you press the ENTER switch after selecting 2: IP296, the sensor displayed is confirmed as IP296 and the system returns to the measurement mode.  
 If you press the MENU switch, the confirmation of the sensor is canceled and the system returns to the measurement mode.

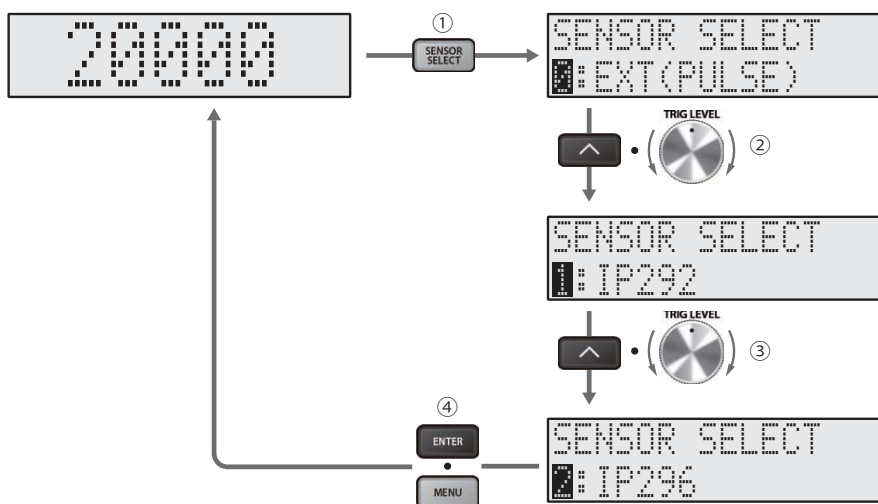

**4** Check the sensor (IP296) setting.  
 If you press the SENSOR SELECT switch, the specified sensor (2: IP296) appears.

If it does not appear, repeat the procedure from step **1** in order.

You can return to the measurement mode by pressing the SENSOR SELECT switch or the ENTER switch.

**● Change and confirm condition values**

This section describes how to change and confirm values taking the procedure to set the trigger level to 98.8 as an example.

- 1** Turn the TRIGGER LEVEL ADJUSTMENT dial to the right/left to enter the trigger level setup mode (TRIG).

In the trigger level setup mode, the measured value is shown in the upper line (MEAS:) and the trigger level is shown in the lower line (TRIG:).

- 2** Set the trigger level.

Press the RIGHT ARROW (>) switch to select (highlight) the digit to set, and change the value (0 to 9) by pressing the upward (^) switch. Change the shown trigger level to 98.8 by repeating the operations above.

You can decrease/increase the selected digit of the trigger level by turning the trigger level adjusting dial (clockwise: increase, counter-clockwise: decrease).

After selecting the first decimal point by pressing RIGHT ARROW (>) switch, turn the TRIGGER LEVEL ADJUSTMENT dial to the right/left until 98.8 is shown as the trigger level.

- 3** Select (confirm) the sensor.

If you press the ENTER switch, the trigger level is set to 98.8 and the system returns to the measurement mode.

If you press the MENU switch, the trigger level 98.8 is canceled and the system returns to the measurement mode.

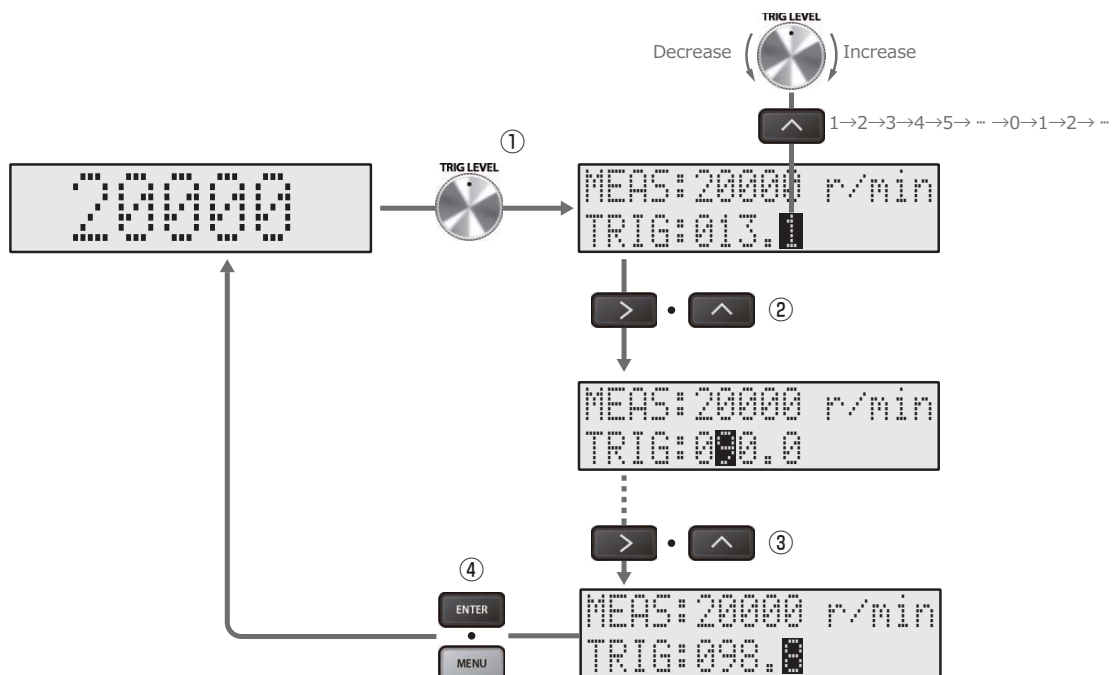

- 4** Check the trigger level (98.8) setting. The set (confirmed) trigger level (98.8) appears when the TRIGGER LEVEL ADJUSTMENT dial is turned to the right/left and the trigger level setup mode (TRIG) is changed.

If the correct trigger level is not shown, repeat the procedure from step **1** in order.

The system returns to the measurement mode if you press the MENU switch or the ENTER switch.

## 1.2 Trigger Level Setup Mode (TRIG)

The measurement mode switches to the trigger level setup mode (TRIG) for trigger level adjustment, and the trigger level (TRIG:) appears in the lower column when the TRIGGER LEVEL ADJUSTMENT dial is turned to the right/left. The measured value is shown in the upper column (MEAS:).

```
MEAS:20000 r/min
TRIG:100.0
```

Item	Description
TRIG:	<ul style="list-style-type: none"> <li>Set the trigger level to a value in the range from 0.0 to 99999. The unit is r/min.</li> <li>The default setting is 100.0.</li> </ul>

## 1.3 Sensor Select Mode (SENSOR SELECT)

Press the SENSOR SELECT switch to enter the sensor select mode (SENSOR SELECT).

```
SENSOR SELECT
0:EXT(PULSE)
```

Item	Description
SENSOR SELECT	<ul style="list-style-type: none"> <li>Select the sensor type from the followings: [0: EXT (PULSE) ], [1: IP292], [2: IP296], [3: IP3000/3100], [4: VP202/1220], [5: OM1200/1500], [6: MP900/9000], [7: LG/MP981] or [8: CRANK PULSE]</li> <li>8: CRANK PULSE is available when the optional CT-0672 ECU crank pulse input is installed.</li> <li>The default setting is 0: EXT (PULSE).</li> </ul>

## 1.4 Pulse Setup Mode (P/R)

When you press the P/R switch, the measurement mode enters the direct setup mode in which the number of pulse (P/R) is set.

```
MEAS:20000 r/min
P/R :0000.0
```

Item	Description
P/R	<ul style="list-style-type: none"> <li>Set the number of pulse to a value in the range from 0.1 to 1000.0 in the unit of 0.1.</li> <li>The default condition value is 0.5.</li> </ul>

## 1.5 Trigger Assist Mode (TRIG ASSIST)

When you press the TRIG ASSIST switch, the system enters the trigger assist mode (TRIG ASSIST) in which the trigger level is automatically adjusted.

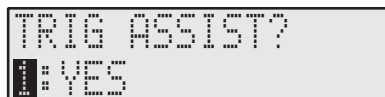

Item	Description
TRIG ASSIST	<ul style="list-style-type: none"> <li>The start of trigger assist can be changed to 1: YES (start) or 0: NO (stop).</li> <li>The default condition value is 1: YES.</li> </ul>

### ● Screen transition of trigger assist mode

During the automatic adjustment of the trigger level, the screen changes as follows.

Screen transition	Screen status
	<ul style="list-style-type: none"> <li>The screen shown during the automatic adjustment of the trigger level.</li> </ul>
	<ul style="list-style-type: none"> <li>The screen shown when the trigger assist is completed successfully.</li> <li>When you press the ENTER switch, the trigger level specified in the trigger assist mode is confirmed, the trigger assist mode exits and the system returns to the measurement mode.</li> </ul>
	<ul style="list-style-type: none"> <li>The screen shown when an error occurs during the trigger assist process.</li> <li>When you press the ENTER switch, the trigger level specified in the trigger assist mode is canceled, the trigger assist mode exits and the system returns to the measurement mode.</li> </ul>

## 1.6 ECU Crank Pulse Calibration Mode (CRANK PULSE CAL)



- The ECU crank pulse calibration mode (CRANK PULSE CAL) is the menu mode available when the optional CT-0672 ECU crank pulse input is installed. For details on the optional accessories, contact the nearest Ono Sokki sales office or the distributor where you purchased the product.

If the optional CT-0672 ECU crank pulse input is installed, when you press the TRIG ASSIST switch, the measurement mode enters the ECU crank pulse calibration mode (CRANK PULSE CAL) in which the necessary conditions for the measurement are set automatically.



Item	Description
CRANK PULSE CAL	<ul style="list-style-type: none"> <li>The automatic setting for the ECU crank pulse signal is set to 1: AUTO (automatic) or 2: GEAR NUM SET. The default condition value is 1: AUTO (automatic).</li> </ul>



● **ECU crank pulse automatic menu mode (1: AUTO)**

When you select 1: AUTO in the ECU crank pulse calibration mode (CRANK PULSE CAL) and press the ENTER switch, the system enters the ECU crank pulse automatic setup mode in which the ECU crank pulse is automatically set.

During the ECU crank pulse automatic setup, the screen changes as follows.

Screen transition

Screen status



- The screen shown during the ECU crank pulse automatic setup.



- The screen shown when the ECU crank pulse automatic setup is completed successfully.
- When you press the ENTER switch, the value set in the ECU crank pulse automatic setup is confirmed, the ECU crank pulse automatic setup mode exits and the system returns to the measurement mode.
- When the ECU crank pulse automatic setup is completed successfully, the number of pulse is automatically set to 1.



- The screen shown when an error occurs during the ECU crank pulse automatic setup process.
- When you press the ENTER switch, the value set in the ECU crank pulse automatic setup is canceled, and the system returns to the measurement mode.

● **ECU crank manual setup screen (2: GEAR NUM SET)**

When you select 2: GEAR NUM SET in the ECU crank pulse calibration mode (CRANK PULSE CAL) and press the ENTER switch, the system enters the ECU crank pulse manual setup screen shown below in which the ECU crank pulse is set manually.



In this example, the number of pulse per circumference of the crank pulse plate is set in the range of 0 to 99.

Example 1: Increase 2 gears/12 gears = input 14

Example 2: Decrease 2 gears/12 gears = input 10

Example 1: adds 2 gears to 12 gears

Example 2: reduces 2 gears from 12 gears

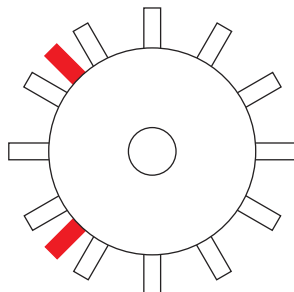

■ : added gears

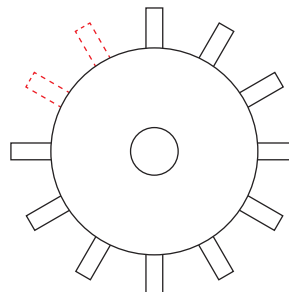

▭ : reduced gears

## 2. Menu Reference

### 2.1 List of Menu Structure

Each press of the MENU switch toggles the currently displayed screen between the measurement mode and the menu mode.

The operations to select the condition for the menu screen and to change values are the same as the menu mode such as the trigger level setup mode. For details, refer to “Setting Operation for Conditions and Values in Menu Mode” on page 42.

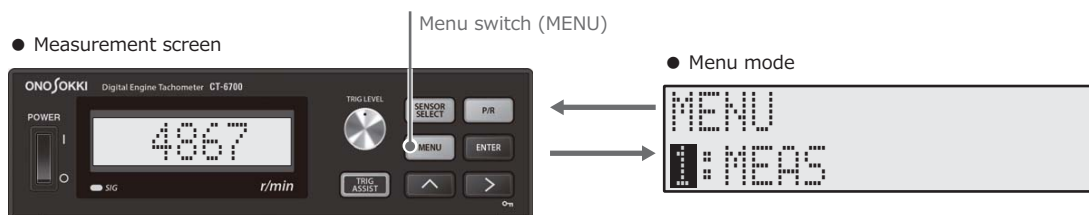

Item	Description	Reference
0: VERSION	Version display	Page 49
1: MEAS	Setting measurement conditions	Page 49
	0: RANGE                      Setting range conditions	Page 49
	1: GAIN                        Setting gain conditions	Page 50
	2: FACTOR                    Setting factor conditions	Page 50
	3: AVERAGE                Setting moving average conditions	Page 50
	4: REDUCE                    Setting deceleration conditions	Page 51
2: P-OUT	Setting pulse output conditions	Page 52
3: V-OUT	Setting output voltage conditions	Page 52
4: COMP-OUT	Setting comparator output conditions	Page 53
	0: ENGINE RUN              Setting engine run conditions	Page 54
	1: OVER RUN                Setting overrun conditions	Page 55
5: DISPLAY	Setting display conditions for fluorescent display tube	Page 56
	0: UPDATE                    Setting update interval	Page 56
	1: BRIGHT                    Setting brightness conditions	Page 57
	2: MODE                      Setting display mode for measurement mode screen	Page 57
6: RS-232C	Setting RS-232C interface conditions	Page 58
	0: BAUDRATE                Setting baud rate conditions	Page 58
	1: MODE                      Setting mode conditions	Page 57
7: CON MEMORY	Setting condition memory	Page 59
	0: SAVE                      Setting save conditions of the memory condition	Page 59
	1: LOAD                      Setting load conditions of the memory condition	Page 59
	2: CLEAR                    Setting delete conditions of the memory condition	Page 60
8: CAL	Setting calibration conditions	Page 60
	0: ZERO                      Setting calibration signal output ZERO conditions	Page 60
	1: FULL                      Setting calibration signal output FULL conditions	Page 60
9: CAN-OUT	Setting CAN output conditions	Page 61
	0: BAUDRATE                Setting baud rate conditions	Page 61
	1: ID                         Setting ID conditions	Page 61
	2: UPDATE                    Setting output update frequency conditions	Page 62
	3: TERM                      Setting terminal conditions	Page 62

## 2.2 Version Display (0: VERSION)

If you press the ENTER switch after selecting 0: VERSION in the menu mode, the VERSION information appears.

### ■ Version Information Display (0: VERSION)

The DSP and FPGA version is shown in the VERSION information.

If you press the MENU switch after checking the version, the system returns to the menu mode.



Item	Description
VERSION	<ul style="list-style-type: none"> <li>• DSP Shows the version of DSP (digital signal processor) installed in the CT-6700 digital engine tachometer.</li> <li>• FPGA Shows the version of FPGA (Filed Programmable Gate Array) installed in the CT-6700 digital engine tachometer.</li> </ul>

## 2.3 Setting Measurement Conditions (1: MEAS)

If you press the ENTER switch after selecting 1: MEAS in the menu mode, the system switches to MEAS (measurement condition setup).

In MEAS, the detailed setting items of 0: RANGE, 1: GAIN, 2: FACTOR, 3: AVERAGE and 4: REDUCE are stored.

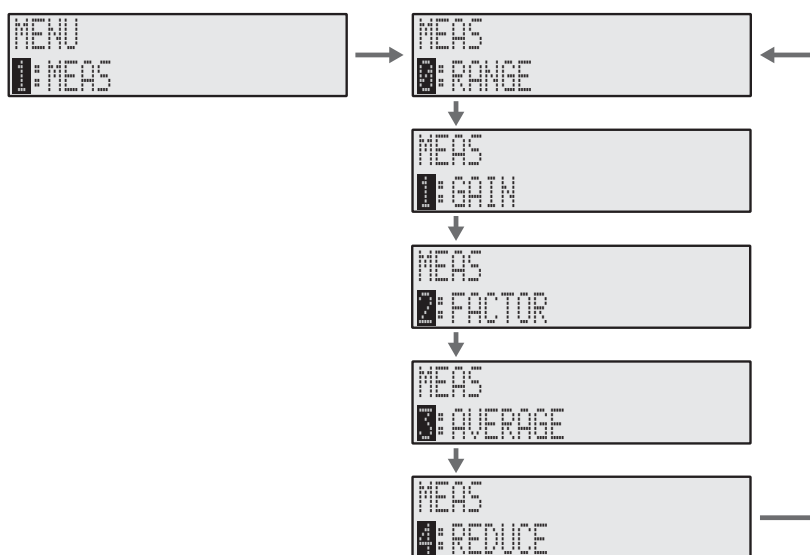

### ■ Setting Range Conditions (0: RANGE)

If you press the ENTER switch after selecting 0: RANGE in MEAS, the system switches to MEAS > RANGE (range condition setup).



Item	Description
RANGE	<ul style="list-style-type: none"> <li>• Sets the range between 1 to 99999 (in r/min). The default condition value is 20000.</li> </ul>

### ■ Setting Gain Conditions (1: GAIN)

If you press the ENTER switch after selecting 1: GAIN in MEAS, the system switches to MEAS > GAIN (gain condition setup).



Item	Description
GAIN	<ul style="list-style-type: none"> <li>• Allows you to select a gain from the following: [0: LOW] (default), [1: MID] or [2: HI].</li> <li>• 0: LOW (default) Gain × 1/1: MID Gain × 2/2: HI Gain × 8</li> </ul>

### ■ Setting Factor Conditions (2: FACTOR)

If you press the ENTER switch after selecting 2: FACTOR in MEAS, the system switches to MEAS > FACTOR (factor condition setup).



Item	Description
FACTOR	<ul style="list-style-type: none"> <li>• Sets the factor value. The default setting is 1.0000E+0.</li> <li>• Setting range for mantissa: 0.0001 to 1.0000</li> <li>• Setting range for exponent: E+0 to E+4</li> </ul>

### ● Setting factor conditions when OM-1200/1500 is connected

If the OM-1200/1500 Motor/gasoline engine RPM detector is not connected to the CT-6700 digital engine tachometer, please set the FACTOR condition to 1.0000E+0.

Use the following formula to set the conditions if the OM-1200/1500 Motor/gasoline engine RPM detector installed on the engine alternator is connected to the CT-6700 digital engine tachometer.

P/R	= Number of polarity of alternator × (1/2)
(number of pulse)	• For details on the P/R setting, refer to "1.4 Pulse Setup Mode (P/R)" on page 45.
FACTOR	= 1 / Pulley-speed increasing ratio

### ■ Setting Moving Average Conditions (3: AVERAGE)

If you press the ENTER switch after selecting 3: AVERAGE in MEAS, the system switches to MEAS > AVERAGE (moving average condition setup).



Item	Description
AVERAGE	<ul style="list-style-type: none"> <li>• Sets the number of moving average between 1 to 720. The default condition value is 1.</li> </ul>

### ■ Setting Deceleration Conditions (4: REDUCE)

If you press the ENTER switch after selecting 4: REDUCE in MEAS, the system switches to MEAS > REDUCE (deceleration condition setup).

In the REDUCE condition, two detailed setting conditions ; stop time (ESTIMATE) and the keep time (KEEP) of the estimate calculation are stored.

Press UPWARD (^) switch to change to 0: ESTIMATE or 1: KEEP and press the ENTER switch. The previously saved REDUCE > ESTIMATE or REDUCE > KEEP screen appears.

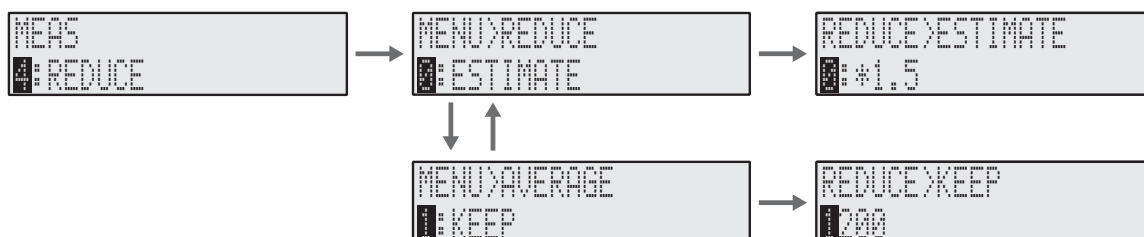

Item	Description
ESTIMATE	<ul style="list-style-type: none"> <li>Allows you to select a stop time of the estimate calculation from the following: [0: *1.5], [1: *3], [2: *5], [3: *8] and [4: *16]. The default condition value is 1: *3.</li> </ul>
KEEP	<ul style="list-style-type: none"> <li>Sets the keep time (KEEP) in the range between 1 to 1200 (in ms). The default condition value is 1200.</li> </ul>

### ● Deceleration condition setup function

The deceleration condition setup function is the function to decrease/stop the analog signal output when the input signal from the sensor decreases dramatically and there is no signal input over the period longer than the previous pulse interval.

The stop time of estimate calculation (ESTIMATE) is the function to decrease the power output to 0V (stop) precipitously without any midpoints. The figure on the left shows the waveform image till the output stops when the estimate calculation stop time (ESTIMATE) is set to \*5.

The keep time (KEEP) sets the analog signal output to 0V at the specified time. The figure on the right shows the waveform image till the output stops when the keep time (KEEP) is set to 1000 ms.

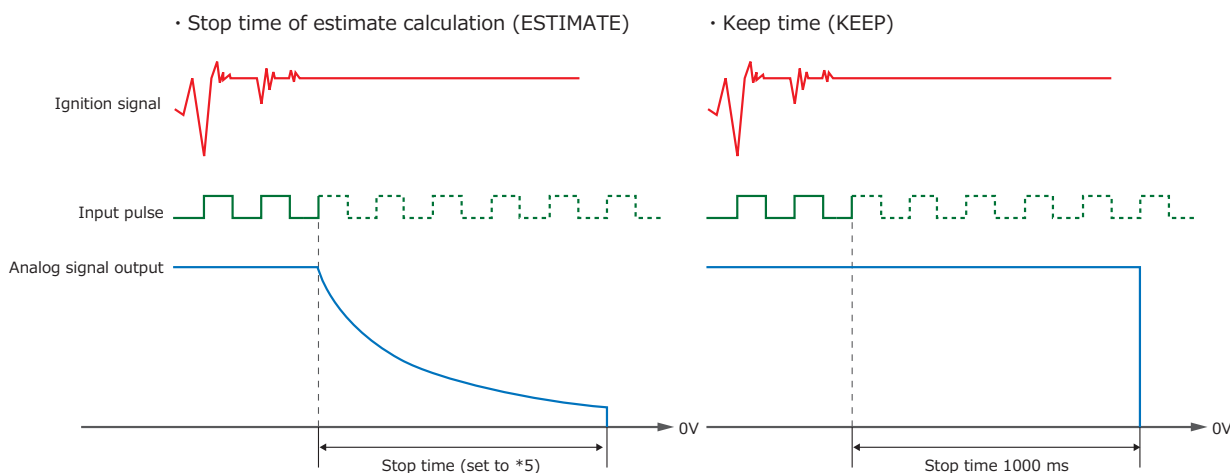

## 2.4 Setting Pulse Output Conditions (2: P-OUT)

If you press the ENTER switch after selecting 2: P-OUT in the menu mode, the system switches to P-OUT (pulse output condition setup).

### ■ Setting Pulse Output Conditions (2: P-OUT)

Sets the pulse output condition in the P-OUT (pulse output condition setup) screen.



Item	Description
P-OUT	<ul style="list-style-type: none"> <li>Select the pulse output condition from [0: DIRECT], [1: 0.5PR], [2: 1PR] or [3: 60PR]. The default condition value is 0: DIRECT.</li> <li>0: DIRECT Performs the waveform shaping on the input signal waveform and outputs it in no greater than 10<math>\mu</math>s.</li> <li>1: 0.5PR, 2: 1PR, 3: 60 PR 入力信号1 回転の周期から設定されているパルス数を出力します。</li> </ul>

### ● Setting INVERT conditions (0: INVERT)

Press UPWARD (^) switch in the P-OUT (pulse output condition setup) to change to the 0: DIRECT screen and press the ENTER switch. The previously saved P-OUT > DIRECT screen appears.

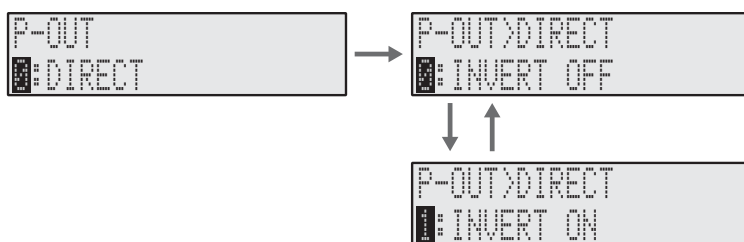

Item	Description
INVERT	<ul style="list-style-type: none"> <li>You can switch the INVERT ON (enabled) or OFF (disabled) when DIRECT is selected as the pulse output condition. The default condition value is 0: OFF.</li> </ul>

## 2.5 Setting Output Voltage Conditions (3: V-OUT)

If you press the ENTER switch after selecting 3: V-OUT in the menu mode, the system switches to 3: V-OUT (output voltage condition setup).

### ■ Setting Output Voltage Conditions (3: V-OUT)

Sets the analog output condition in V-OUT (analog output condition setup).



Item	Description
------	-------------

V-OUT	<ul style="list-style-type: none"> <li>Select the analog output condition from [0: PULSE] and [1: 1ms]. The default condition value is 0: PULSE.</li> <li>0: PULSE The output is updated for every input signal.</li> <li>1: 1ms The output is updated in 1ms regardless of the timing of input signal.</li> </ul>
-------	--

## 2.6 Setting Comparator Output Conditions (4: COMP-OUT)

If you press the ENTER switch after selecting 4: COM-OUT in the menu mode, the system switches to COM-OUT (comparator output condition setup).

The detailed setting items of 0: ENGINE RUN and 1: OVER RUN are stored in COMP-OUT.

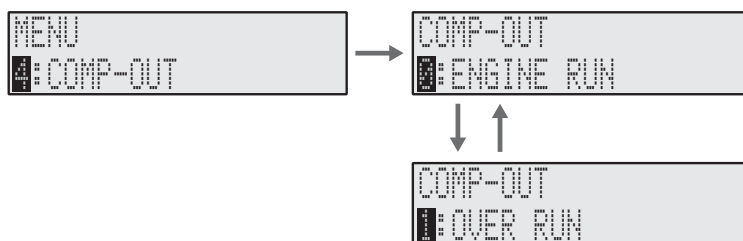

### ■ Working mechanism of comparator output

#### ● Judgment mechanism and examples

The following is the output operation example of the comparator when the engine run and overrun (VALUE) condition is set.

If the engine run is set to 500 r/min, the engine is regarded as started when the engine rotation speed exceeds 500 r/min.

If the overrun is set to 6000 r/min, the engine is regarded as abnormal when the engine rotation speed exceeds 6000 r/min.

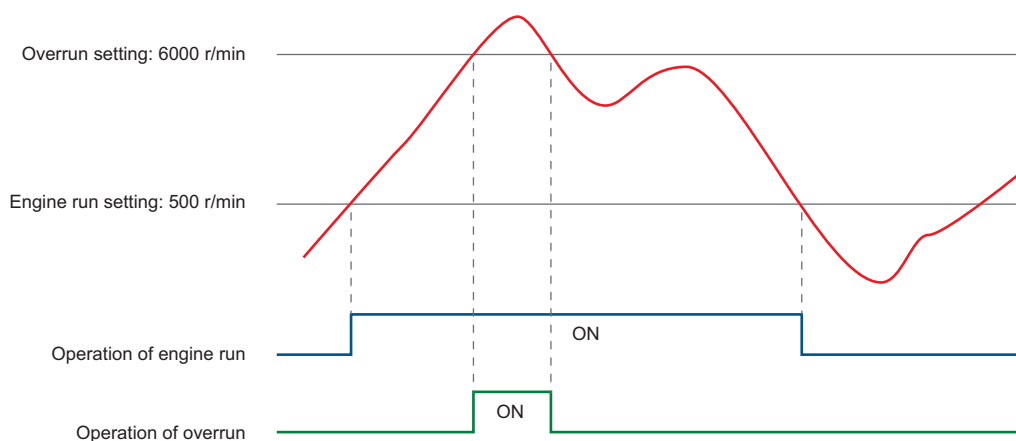

#### ● Hysteresis mechanism

The following is the output operation example of the comparator when hysteresis is set to 10%.

When the engine rotation speed goes lower than the engine run (overrun) judgment value (630 r/min, 10% minus 700 r/min), it returns to normal.

The ON/OFF operation of engine run and overrun is decided based on the hysteresis setting for both

engine run and overrun.

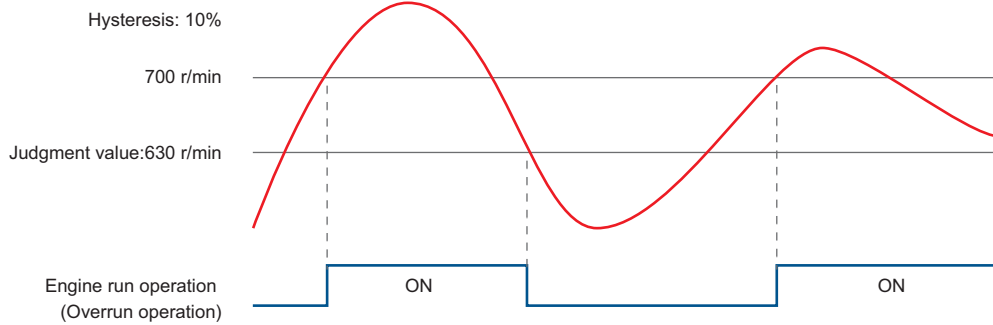

■ Setting Engine Run Conditions (0: ENGINE RUN)

If you press the ENTER switch after selecting 0: ENGINE RUN in the COMP-OUT screen, the system switches to ENGINE RUN (ENGINE RUN condition setup).

The detailed setting items of 0: VALUE, 1: MODE and 2: HYSTERESIS are stored in ENGINE RUN.

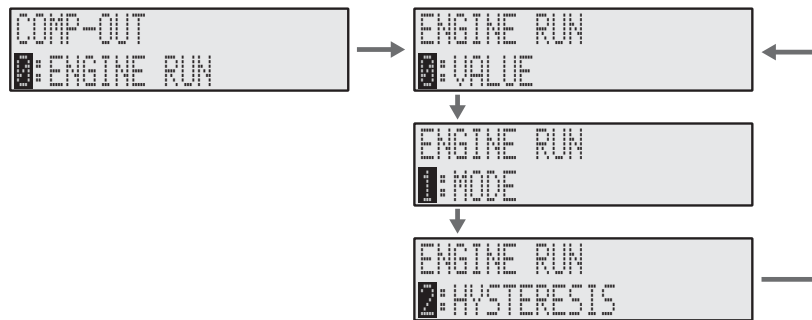

● Setting engine run judgment conditions (0: VALUE)

Press UPWARD (^) switch to change to 0: VALUE and press the ENTER switch. The previously saved ENGINE RUN > VALUE screen appears.



Item	Description
VALUE	<ul style="list-style-type: none"> <li>Sets the judgment value of engine run in the range between 1 to 99999 (r/min). The default condition value is 400.</li> </ul>

● Setting engine run contact mode conditions (1: MODE)

Press UPWARD (^) switch in ENGINE RUN to change to 1: MODE and press the ENTER switch. The previously saved ENGINE RUN > MODE screen appears.

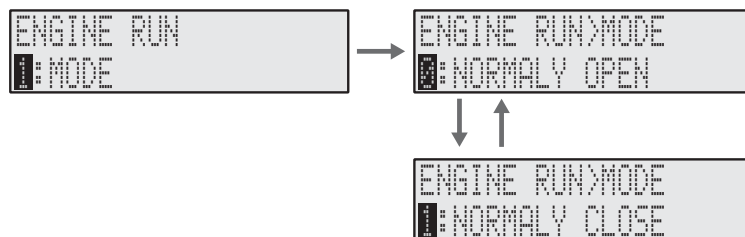



Item	Description
MODE	<ul style="list-style-type: none"> <li>Set the overrun contact mode to [0: NORMALY OPEN] or [1: NORMALY CLOSE]. The default condition value is 0: NORMALY OPEN.</li> </ul>

● **Setting hysteresis conditions (2: HYSTERESIS)**

Press UPWARD (^) switch in ENGINE RUN to change to 2: HYSTERESIS and press the ENTER switch. The previously saved ENGINE RUN > HYS screen appears.



Item	Description
HYS	<ul style="list-style-type: none"> <li>Sets the hysteresis in the range between 0 to 20 (%). The default condition value is 0.</li> </ul>

■ **Setting Overrun Conditions (1: OVER RUN)**

If you press the ENTER switch after selecting 1: OVER RUN in the COMP-OUT screen, the system switches to OVER RUN (OVER RUN condition setup).

The detailed setting items of 0: VALUE, 1: MODE and 2: HYSTERESIS are stored in OVER RUN.

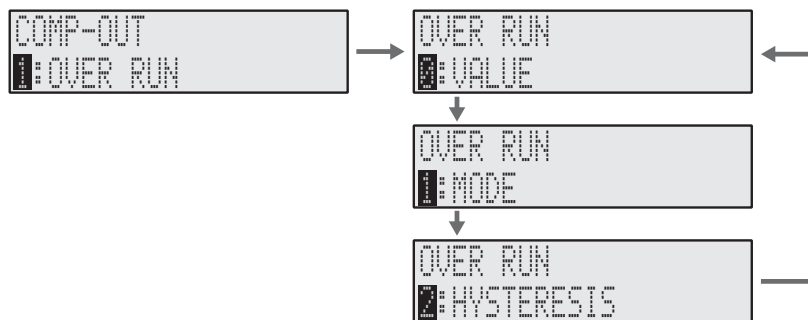

● **Setting overrun judgment conditions (0: VALUE)**

Press UPWARD (^) switch in OVER RUN to change to 0: VALUE, and press the ENTER switch. The previously saved OVER RUN > VALUE screen appears.



Item	Description
VALUE	<ul style="list-style-type: none"> <li>Sets the judgment value of overrun in the range between 1 to 99999. The default condition value is 6000.</li> </ul>

● **Setting engine run contact mode conditions (1: MODE)**

Press UPWARD (^) switch in OVER RUN to change to 1: MODE and press the ENTER switch. The previously saved OVER RUN > MODE screen appears.

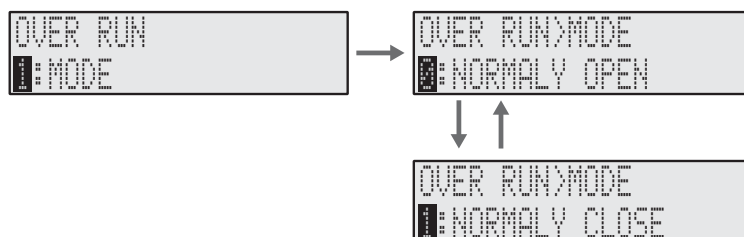

Item	Description
MODE	<ul style="list-style-type: none"> <li>Set the overrun contact mode to [0: NORMALY OPEN] or [1: NORMALY CLOSE]. The default condition value is 0: NORMALY OPEN.</li> </ul>

● **Setting hysteresis conditions (2: HYSTERESIS)**

Press UPWARD (^) switch in OVER RUN to change to 2: HYSTERESIS and press the ENTER switch. The previously saved OVER RUN > HYS screen appears.

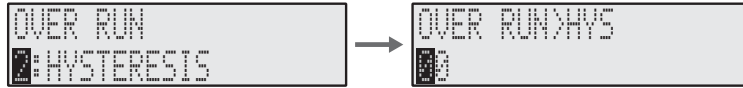

Item	Description
HYS	<ul style="list-style-type: none"> <li>Sets the hysteresis in the range between 0 to 20 (%). The default condition value is 0.</li> </ul>

## 2.7 Setting Display Conditions for Fluorescent Display Tube (5: DISPLAY)

If you press the ENTER switch after selecting 5: DISPLAY in the menu mode, the system switches to DISPLAY (display condition setup for fluorescent tube).

The detailed setting items of 0: UPDATE, 1: BRIGHT and 2: MODE are stored in DISPLAY.

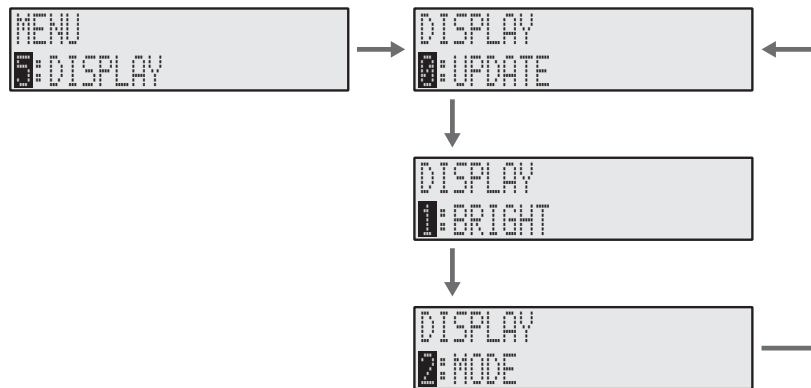

■ **Setting Data Display Update Time Conditions (0: UPDATE)**

If you press the ENTER switch after selecting 0: PDATE in DISPLAY, the system switches to DISPLAY > UPDATE (data display update time condition setup).



Item	Description
UPDATE	<ul style="list-style-type: none"> <li>Select the data display update time from [0: 0.1s], [1: 0.2s], [2: 0.5s] and [3: 1.0s]. The default condition value is 3: 1.0s.</li> </ul>

### ■ Setting Brightness Conditions for Fluorescent Tube (1: BRIGHT)

If you press the ENTER switch after selecting 1: BRIGHT in DISPLAY, the system switches to DISPLAY > BRIGHT (brightness condition setup for fluorescent tube).



Item	Description
BRIGHT	<ul style="list-style-type: none"> <li>Select the brightness of fluorescent display tube from [0: 25%], [1: 50%], [2: 75%] and [3: 100%]. The default condition value is 3: 100%.</li> <li>Set the brightness suitable to your environment. For example, if high brightness such as 100% is set in a dark environment, it may be too bright to see.</li> </ul>

### ■ Setting Display Mode for Measurement Mode (2: MODE)

If you press the ENTER switch after selecting 2: MODE in DISPLAY, the system switches to DISPLAY > MODE (display mode condition setup for measurement mode).

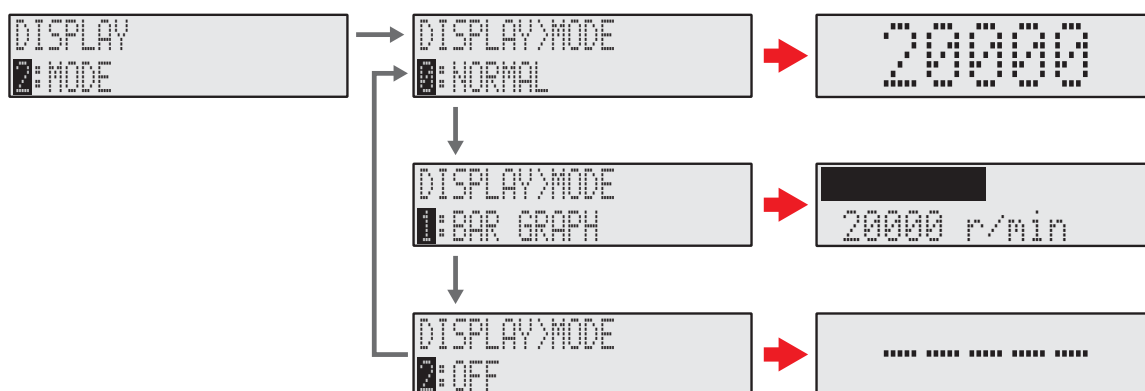

Item	Description
MODE	<ul style="list-style-type: none"> <li>Select the display mode for the measurement mode from [0: NORMAL], [1: BAR GRAPH] and [2: OFF]. The default condition value is 0: NORMAL.</li> <li>0: NORMAL The standard mode for the measurement mode.</li> <li>1: BAR GRAPH The screen mode with the bar graph on the upper column and the measured value on the lower column.</li> <li>2: OFF The screen mode with no measured value shown (-----).</li> </ul>

## 2.8 Setting RS-232C Interface Conditions (6: RS-232C)

If you press the ENTER switch after selecting 6: RS-232C in the menu mode, the system switches to RS-232C (RS-232C interface condition setup).

The detailed setting items of 0: BAUDRATE and 1: MODE are stored in RS232C.

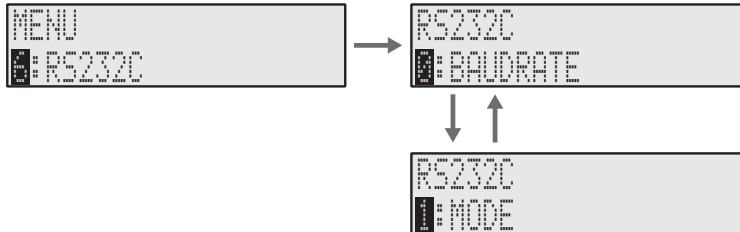

### ■ Setting Baud Rate (Transmission Speed) Conditions (0: BAUDRATE)

If you press the ENTER switch after selecting 0: BAUDRATE in RS232C, the system switches to RS232C > BAUDRATE (baud rate condition setup).



Item	Description
BAUDRATE	<ul style="list-style-type: none"> <li>Select the baud rate (transmission speed) from [0: 9600ps] and [1: 38400bps]. The default condition value is 1: 38400bps.</li> </ul>

### ■ Setting RS232C Mode Conditions (1: MODE)

If you press the ENTER switch after selecting 1: MODE in RS232C, the system switches to RS232C > MODE (RS232C mode condition setup).



Item	Description
MODE	<ul style="list-style-type: none"> <li>Set the RS232C mode to [0: COMMAND] or [1: CONTINUOUS]. The default condition value is 0: COMMAND.</li> <li>0: COMMAND Sends/receives every command.</li> <li>1: CONTINUOUS Sends the measured value continuously according to the set value of display update time (0.1s, 0.2s, 0.5s or 1.0s).</li> </ul>

## 2.9 Setting Memory Conditions (7: COND MEMORY)

The CT-6700 digital engine tachometer is equipped with five memories to store the condition setting data.

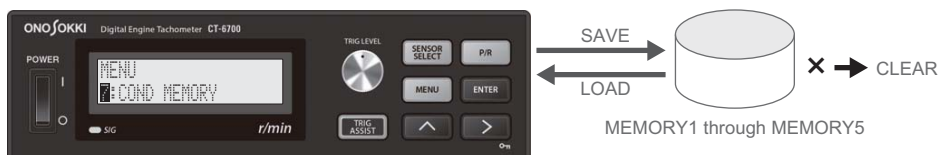

CAUTION

- No message is shown during the writing (SAVE), loading (LOAD) and deleting (CLEAR) the memory operation or when these operations are completed. Thus, please note that overwriting of data with the same memory address or deleting of the necessary data might occur.

If you press the ENTER switch after selecting 7: COND MEMORY in the menu mode, the system switches to COND MEMORY (condition setup of the condition memory).

The detailed setting items of 0: SAVE, 1: LOAD and 2: CLEAR are stored in COND MEMORY.

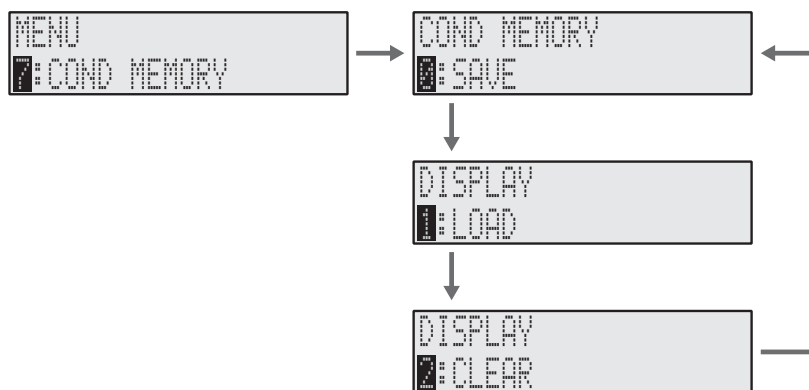

### ■ Setting Save Conditions of Condition Memory (0: SAVE)

If you press the ENTER switch after selecting 0: SAVE in COND MEMORY, the system switches to COND MEMORY > SAVE (save condition setup of the condition memory).

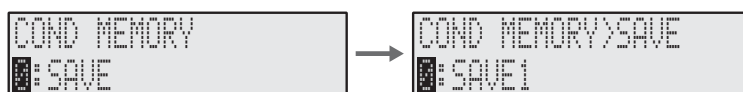

Item	Description
SAVE	<ul style="list-style-type: none"> <li>Select the memory to save the condition (setting condition) from [0: SAVE1] to [4: SAVE5]. The default condition value is 0: SAVE1.</li> </ul>

### ■ Setting Load Conditions of Condition Memory (1: LOAD)

If you press the ENTER switch after selecting 1: LOAD in COND MEMORY, the system switches to COND MEMORY > LOAD (load condition setup of the condition memory).



Item	Description
LOAD	<ul style="list-style-type: none"> <li>Select the condition memory to load from [0: LOAD1] to [4: LOAD5]. The default condition value is 0: LOAD1.</li> </ul>

**■ Setting Delete Conditions of Condition Memory (2: CLEAR)**

If you press the ENTER switch after selecting 2: CLEAR in COND MEMORY, the system switches to COND MEMORY > CLEAR (delete condition setup of the condition memory) screen appears.

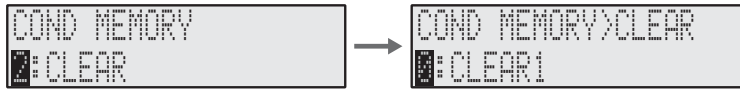

Item	Description
CLEAR	<ul style="list-style-type: none"> <li>Select condition memory to delete from [0: CLEAR1] to [4: CLEAR5]. The default condition value is 0: CLEAR1.</li> </ul>

## 2.10 Setting Calibration Conditions (8: CAL)

If you press the ENTER switch after selecting 8: CAL in the menu mode, the system switches to CAL (calibration signal output condition setup).

The detailed setting items of 0: ZERO and 1: FULL are stored in CAL.

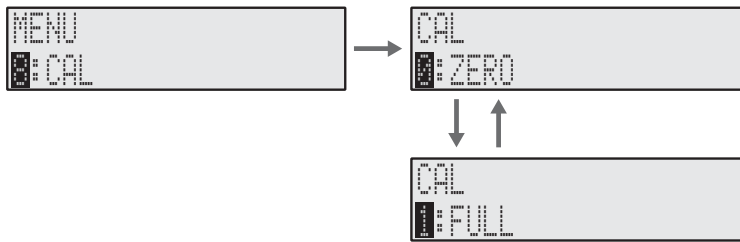

**■ Setting Calibration Signal Output ZERO Conditions (0: ZERO)**

If you press the ENTER switch after selecting 0: ZERO in the menu mode, the system switches to CAL > ZERO (calibration signal output ZERO condition setup). The ZERO output can be fine-tuned by setting the value.



Item	Description
ZERO	<ul style="list-style-type: none"> <li>Sets the ZERO output value of calibration signal in the range between 0 to 100. The default condition value is 50.</li> </ul>

**■ Setting Calibration Signal Output FULL Conditions (1: FULL)**

If you press the ENTER switch after selecting 1:FULL in CAL, the system switches to CAL > FULL (calibration signal output FULL condition setup). The FULL output can be fine-tuned by setting the value.



Item	Description
FULL	<ul style="list-style-type: none"> <li>Sets the FULL output value of calibration signal in the range between 0 to 100. The default condition value is 50.</li> </ul>

## 2.1.1 Setting CAN Output Conditions (9: CAN-OUT)



- The menu mode 9: CAN-OUT (CAN output condition setup) screen is available when the optional CT-0671 CAN output is installed. The screen is not displayed if it is not installed.
- For details on the optional accessories, contact the nearest Ono Sokki sales office or the distributor where you purchased the product.

If you press the ENTER switch after selecting 9: CAN-OUT in the menu mode, the system switches to CAN-OUT (CAN output condition setup).

The detailed setting items of 0: BAUDRATE, 1: ID, 2: UPDATE and 3: TERM are stored in CAN-OUT.

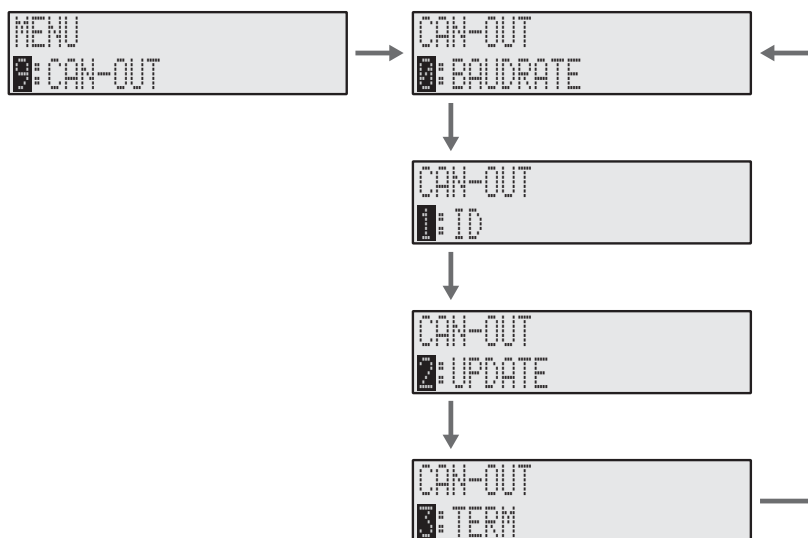

### ■ Setting Baud Rate Conditions for CAN Output Signal (0: BAUDRATE)

If you press the ENTER switch after selecting 0: BAUDRATE in CAN-OUT, the system switches to CAN-OUT > BAUDRATE (baud rate condition setup for CAN output signal).



Item	Description
BAUDRATE	<ul style="list-style-type: none"> <li>• Select the baud rate (transmission speed) of the CAN output signal from [0: 125kbps], [1: 250kbps], [2: 500kbps] and [3: 1Mbps]. The default condition value is 2: 500kbps.</li> </ul>

### ■ Setting ID Conditions for CAN Output Signal (1: ID)

If you press the ENTER switch after selecting 1: ID in CAN-OUT, the system switches to CAN-OUT > ID (ID condition setup for CAN output signal).



Item	Description
ID	<ul style="list-style-type: none"> <li>• Select the ID of CAN output signal from 0x001 to 0x7FF. The default condition value is 0x711.</li> </ul>

**■ Setting Output Update Frequency Conditions for CAN Output Signal (2: UPDATE)**

If you press the ENTER switch after selecting 2: UPDATE in CAN-OUT, the system switches to CAN-OUT > UPDATE (update frequency condition setup for CAN output signal).

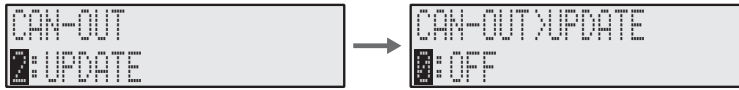

Item	Description
UPDATE	<ul style="list-style-type: none"> <li>Select the update frequency condition for CAN output signal from [0: OFF], [1: 1], [2: 2], [3: 5], [4: 10], [5: 20], [6: 100] and [3: 1000]. The unit is in Hz. The default condition value is 0: OFF.</li> </ul>

**■ Setting Terminal Resistance Conditions for CAN Output Signal (3: TERM)**

If you press the ENTER switch after selecting 3: TERM in CAN-OUT, the system switches to CAN-OUT > TERM (terminal resistance condition setup for CAN output signal).

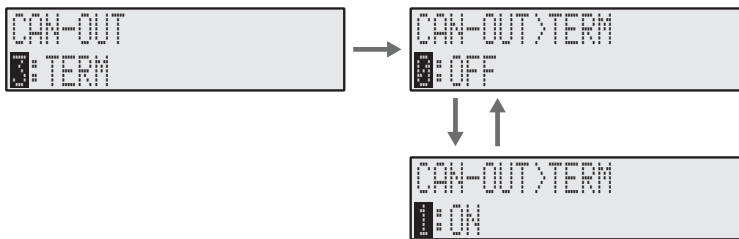

Item	Description
TERM	<ul style="list-style-type: none"> <li>Set the terminal resistance condition for CAN output signal to [0: OFF] or [1: ON]. The default condition value is 0: OFF.</li> </ul>



# Chapter 4

## Interface Reference

1. RS-232C Interface 64
2. CAN Interface 71

# 1. RS-232C Interface

## 1.1 Overview of RS-232C Interface

### Overview of RS-232C

The RS-232C interface is a method to operate (control) the CT-6700 digital engine tachometer from the personal computer or PLC (Programmable Logic Controller) connected to the CT-6700 digital engine tachometer via the RS-232C interface.

### RS-232C System Configuration

Connect the RS-232C connector located on the rear panel of the CT-6700 digital engine tachometer to the personal computer or PLC using the AX-5022 RS-232C cable (optional).

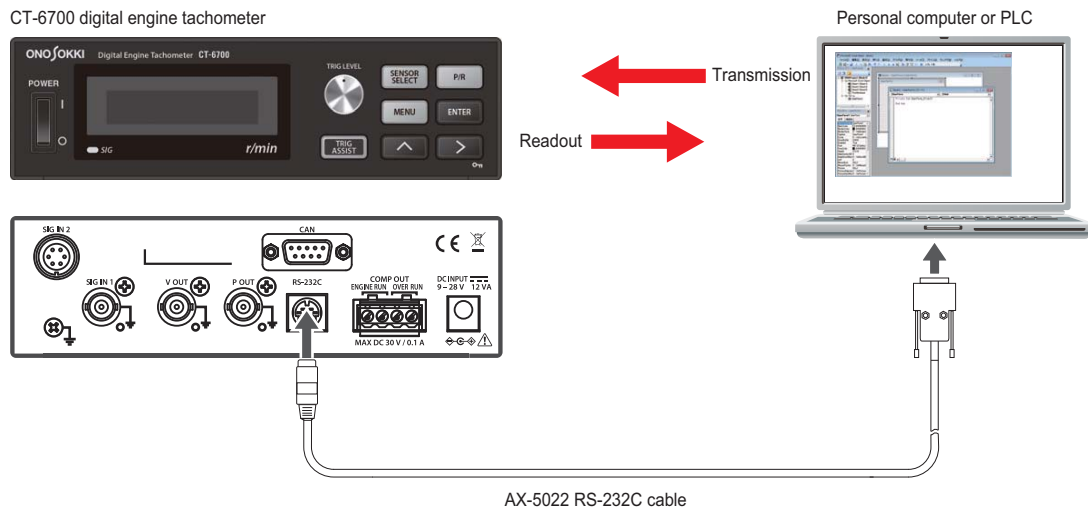

### External View and Specifications of RS-232C Connector

#### External view and pin arrangement of RS-232C

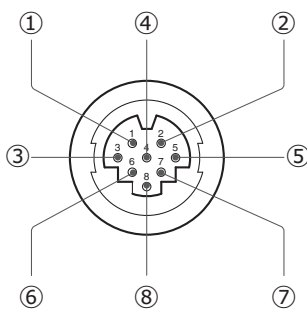

Pin No.	Signal name	Function	Input/output
①	FG	Ground	-
②	RxD	Data reception	Input
③	TxD	Data transmission	Output
④	NC (CTS)	-	-
⑤	NC (RTS)	-	-
⑥	RESERVE	Reserved	Connection not allowed
⑦	COM	Signal ground	-
⑧	NC	No Connect	-

### ● Specifications of RS-232C

Communication mode	Asynchronous full-duplex mode	
Transmission rate	9600 bps/38400 bps (optional)	
Character length	8 bit	
Parity check	N/A	
Stop bit length	1 bit	
X parameter control	N/A	
Hardware flow control	None	
Terminator	CR + LF	
Signal level	Conforms to EIA-232	
	Input voltage range	±25 V
	Output voltage amplitude	±5 V min

### ■ Command Types

The following three types (Type 1 to 3) of commands are available for the functions of the built-in RS-232C interface in the CT-6700 digital engine tachometer.

Type	Description
Type 1	Three-character commands terminated after sent to the CT-6700 digital engine tachometer.
Type 2	Three-character commands followed by required parameters. All parameters must consist of ASCII alphanumeric characters to which a parameter of specified length needs to be added unless the parameter is of variable length. If a parameter begins with the space character (character code: 0x20), the space character cannot be omitted.
Type 3	Reads the ASCII characters re-directed from the CT-6700 digital engine tachometer after sending three-character commands (adding parameters as necessary). Receive the exact fixed amount of data sent from the CT-6700 digital engine tachometer.



- When sending Type-1 commands or Type-1 and Type-2 commands in succession, the processor in the CT-6700 digital engine tachometer may fail to process them.  
To avoid this, a receiving buffer is provided in the CT-6700 digital engine tachometer. However, an overflow may still occur when sending commands in succession.  
When sending commands in succession, there must be an interval of about 100 ms.
- The internal memory IC in the CT-6700 digital engine tachometer is used for saving the panel condition data (condition value data) and withstands up to one million times of rewrites.  
The Type-2 MMS command rewrites the panel condition data each time the command is sent. In order to prolong the memory IC life, avoid overuse of the MMS command.

### ■ Error Codes

Error code	Description
ER1	Out of condition value range
ER2	Condition error
ER3	Unregistered command error
ER4	Trigger assist error
ER5	ECU crank pulse signal automatic setting error

## 1.2 RS-232C Command Reference

### ■ Type 1: Read Status Commands

Command	Function	Transmission		Receive		Remarks
		Format	@	Format		
RDD	Read measured value (display value)	RDD?	-	@@@@		Fixed to five digits (zero-suppressed)
MOD	Read mode	MOD?	-	0: Measurement mode 1: Menu mode 2: Sensor select mode 3: Pulse setup mode 4: Trigger level setup mode 5: Trigger assist mode 6: ECU crank pulse calibration mode		
CES	Read engine run contact status	CES?	-	0: OFF 1: ON		-
COS	Read overrun contact status	COS?	-	0: OFF 1: ON		-
VER	Read main unit version	VER?	-	@.@@, #.##		@: DSP version, #: FPGA version

### ■ Type 2: Execution Commands

Command	Function	Transmission		Receive		Remarks
		Format	@	Format		
CAL	Calibration signal output	CAL@	0: OFF 1: ON	G: Successful ER *: Error		No display change For measurement mode only
TAT	Execute trigger assist function	TAT	-	G: Successful ER *: Error		Command reception is restricted until calibration is complete. <ul style="list-style-type: none"> <li>Maximum response time is 8 seconds</li> </ul>
CKC	Execute ECU crank pulse signal automatic setting	CKC	-	G: Successful ER *: Error		Optional Command reception is restricted until calibration is complete. <ul style="list-style-type: none"> <li>Maximum response time is 8 seconds</li> </ul>
MMS	Execute condition memory save	MMS@	0: COND 1 1: COND 2 2: COND 3 3: COND 4 4: COND 5	G: Successful ER *: Error		
MML	Execute condition memory read	MML@	0: COND 1 1: COND 2 2: COND 3 3: COND 4 4: COND 5	G: Successful ER *: Error		
MMC	Execute condition memory clear	MMC@	0: COND 1 1: COND 2 2: COND 3 3: COND 4 4: COND 5	G: Successful ER *: Error		

### ■ Type 3: Set and Read Condition Commands

Command	Function	Transmission		Receive		Remarks
		Format	@	Format		
TRG	Sets trigger level (any value)	TRG@@@.@	000.0 to 100.0	G: Successful ER *: Error		Ignore second decimal point or lower.
	Reads trigger level	TRG?	-	@@@.@ (000.0 to 100.0)		
TUP	Trigger level count up setting	TRS@@@.@	-	G: Successful ER *: Error		Return error when trigger level 000.1 increment 100.0.
TDN	Trigger level count down setting	TDN@@@.@	-	G: Successful ER *: Error		Return error when trigger level 000.1 increment 100.0.
SNS	Connection sensor setting	SNS@	0: EXT 1: IP292 2: IP296 3: IP3000/3100 4: VP202/1220 5: OM1200/1500 6: MP900/9000 7: LG/MP981 8: CRANK (optional)	G: Successful ER *: Error		
	Reads connection sensor	SNS?	-	0: EXT 1: IP292 2: IP296 3: IP3000/3100 4: VP202/1220 5: OM1200/1500 6: MP900/9000 7: LG/MP981 8: CRANK (optional)		
PPR	Sets number of pulse per revolution	PPR@@@@.@	0000.1 to 1000.0	G: Successful ER *: Error		Ignore second decimal point or lower.
	Reads number of pulse per revolution	PPR?	-	@@@@.@ (0000.1 to 1000.0)		
RNG	Sets input range	RNG@@@@@	00001 to 99999	G: Successful ER *: Error		zero-suppressed
	Reads input range	RNG?	-	00001 to 99999		
GIN	Sets gain	GIN@	0: LOW, 1: MID, 2: HI	G: Successful ER *: Error		
	Reads gain	GIN?	-	0: LOW 1: MID 2: HI		
FCT	Sets factor	FCT@.@@@@ E+@	Mantissa: 0.0001 to 1.000 Exponent: 0 to 4	G: Successful ER *: Error		Ignore fifth decimal point or lower
	Reads factor	FCT?	-	@.@@@@E+@ Mantissa: 0.0001 to 9.9999 Exponent: 0 to 4		
AVG	Sets number of moving average	AVG@@@	001 to 720	G: Successful ER *: Error		
	Reads number of moving average	AVG?	-	001 to 720		
RDC	Sets deceleration calculation mode	RDC@	0: ESTIMATE 1: KEEP	G: Successful ER *: Error		
	Reads deceleration calculation mode	RDC?	-	0: ESTIMATE 1: KEEP		

Command	Function	Transmission		Receive		Remarks
		Format	@	Format		
EST	Sets estimate time	EST@	0: *1.5 1: *3 2: *5 3: *8 4: *16	G: Successful ER *: Error		
	Reads estimate time	EST?	-	0: *1.5 1: *3 2: *5 3: *8 4: *16		
KEP	Sets keep time	KEP@@@@	1 to 1200	G: Successful ER *: Error		
	Reads keep time	KEP?	-	1 to 1200		
POT	Sets pulse output	POT@	0: DIRECT 1: 0.5 P/R 2: 1 P/R 3: 60 P/R	G: Successful ER *: Error		
	Reads pulse output	POT?	-	0: DIRECT 1: 0.5 P/R 2: 1 P/R 3: 60 P/R		
PIV	Sets pulse output direct invert	PIV@	0: INVERT OFF 1: INVERT ON	G: Successful ER *: Error		
	Reads pulse output direct invert	PIV?	-	0: INVERT OFF 1: INVERT ON		
VOT	Sets analog output	VOT@	0: PULSE 1: 1 ms	G: Successful ER *: Error		
	Reads analog output	VOT?	-	0: PULSE 1: 1 ms		
CEV	Sets engine run threshold	CEV@@@@	00001 to 99999	G: Successful ER *: Error		
	Reads engine run threshold	CEV?	-	00001 to 99999		
CEM	Sets engine run contact	CEM@	0: NORMALY OPEN 1: NORMALY CLOSE	G: Successful ER *: Error		
	Reads engine run contact	CEM?	-	0: NORMALY OPEN 1: NORMALY CLOSE		
CEH	Sets engine run hysteresis	CEH@@	00 to 20	G: Successful ER *: Error		
	Reads engine run hysteresis	CEH?	-	00 to 20		
COV	Sets overrun threshold	COV@@@@	00001 to 99999	G: Successful ER *: Error		
	Reads overrun threshold	COV?	-	00001 to 99999		
COM	Sets overrun contact	COM@	0: NORMALY OPEN 1: NORMALY CLOSE	G: Successful ER *: Error		
	Reads overrun contact	COM?	-	0: NORMALY OPEN 1: NORMALY CLOSE		
COH	Sets overrun hysteresis	COH@@	00 to 20	G: Successful ER *: Error		
	Read overrun hysteresis	COH?	-	00 to 20		

Command	Function	Transmission		Receive		Remarks
		Format	@	Format		
DUD	Sets display update time	DUD@	0: 0.1 s 1: 0.2 s 2: 0.5 s 3: 1.0 s	G: Successful ER *: Error		
	Reads display update time	DUD?	-	0: 0.1 s 1: 0.2 s 2: 0.5 s 3: 1.0 s		
DBR	Sets display brightness	DBR@	0: 25% 1: 50% 2: 75% 3: 100%	G: Successful ER *: Error		
	Reads display brightness	DBR?	-	0: 25% 1: 50% 2: 75% 3: 100%		
DMD	Sets display mode	DMD@	0: NORMAL 1: BAR GRAPH 2: OFF	G: Successful ER *: Error		
	Reads display mode	DMD?	-	0: NORMAL 1: BAR GRAPH 2: OFF		
RSB	Sets RS232C baud rate	RSB@	0: 9600 bps 1: 38400 bps	G: Successful ER *: Error		Cannot communicate when switched
	Reads RS232C baud rate	RSB?	-	0: 9600 bps 1: 38400 bps		
RSM	Sets RS232C mode	RSM@	0: COMMAND 1: CONTINUOUS	G: Successful ER *: Error		Cannot communicate when CONTINUOUS
	Reads RS232C mode	RSM?	-	0: COMMAND 1: CONTINUOUS		
CLZ	Sets analog output zero adjustment	CLZ@@@	000 to 100	G: Successful ER *: Error		
	Reads analog output zero adjustment	CLZ?	-	000 to 100		
CLF	Sets analog output full adjustment	CLF@@@	000 to 100	G: Successful ER *: Error		
	Reads analog output full adjustment	CLF?	-	000 to 100		
CAB	Sets CAN output baud rate	CAB@	0: 125 kbps 1: 250 kbps 2: 500 kbps 3: 1 Mbps	G: Successful ER *: Error		
	Reads CAN output baud rate	CAB?	-	0: 125 kbps 1: 250 kbps 2: 500 kbps 3: 1 Mbps		
CAI	Sets CAN output ID	CAI@@@	001 to 7FF	G: Successful ER *: Error		Hexadecimal
	Reads CAN output ID	CAI?	-	001 to 7FF		
CAU	Sets output update time	CAU@	0: OFF 1: 1 Hz 2: 2 Hz 3: 5 Hz 4: 10 Hz 5: 20 Hz 6: 100 Hz 7: 1 kHz	G: Successful ER *: Error		

Command	Function	Transmission		Receive	Remarks
		Format	@	Format	
CAU	Reads CAN output update time	CAU?	-	0: OFF 1: 1 Hz 2: 2 Hz 3: 5 Hz 4: 10 Hz 5: 20 Hz 6: 100 Hz 7: 1 kHz	
CAT	Sets CAN output terminal resistance	CAT@	0: OFF 1: ON	G: Successful ER *: Error	
	Reads CAN output terminal resistance	CAT?	-	0: OFF 1: ON	
KPT	Sets key protection	KPT@	0: OFF 1: ON	G: Successful ER *: Error	
	Reads key protection	KPT?	-	0: OFF 1: ON	



## 2. CAN Interface



- The CAN interface is available when the optional CT-0671 CAN output is installed.  
For details on the optional CT-0671 CAN output, contact the nearest Ono Sokki sales office or the distributor where you purchased the product.

### 2.1 Overview of CAN Interface

#### ■ Overview of CAN

CAN stands for Controller Area Network.

#### ■ CAN System Configuration

Connect the LC-0860 CAN cable (that comes with the optional CT-0671 CAN output) to the CAN connector located on the rear panel of the CT-6700 digital engine tachometer as below.

CT-6700 digital engine tachometer

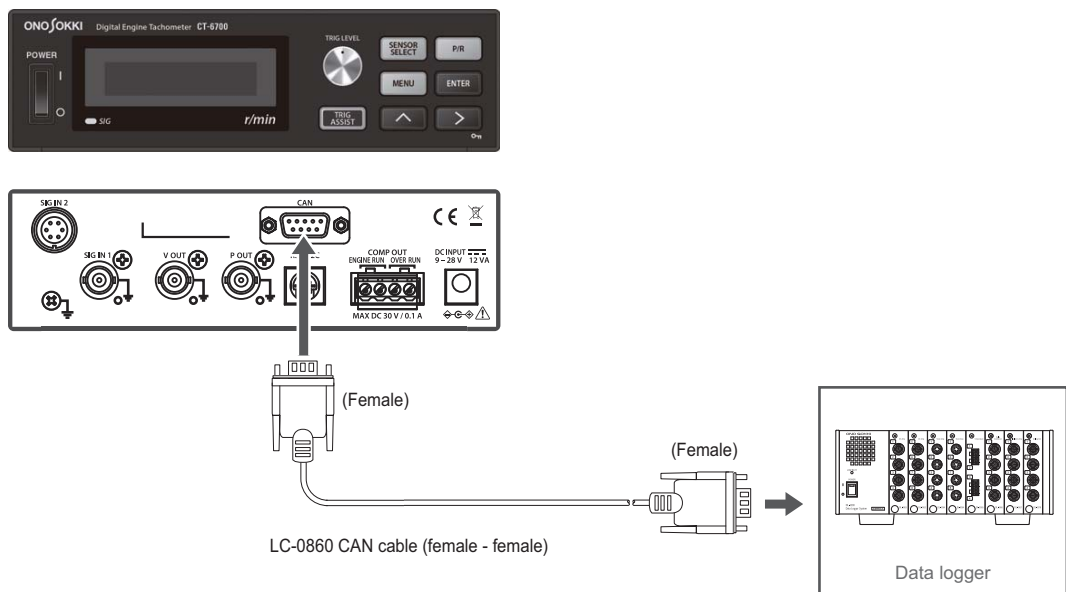

#### ■ External View and Specifications of CAN Connector

##### ● CAN connector specifications

The following is the specification of the CAN connector.

Connector Specification	D-sub/9pin/male connector (main unit side)
-------------------------	--

● **CAN connector pin assignment**

The pin assignment of the CAN connector is shown below.

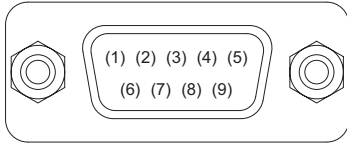

Pin No.	Function
①	NC
②	CAN_Low (output side)
③	GND
④	NC
⑤	GND
⑥	NC
⑦	CAN_High (output side)
⑧	NC
⑨	NC

## 2.2 CAN Data Format

### ■ Output Rate Specifications

Output update rate    1 Hz/2 Hz/5 Hz/10 Hz/20 Hz/100 Hz/1 kHz

Output baud rate      125 kbps, 250 kbps, 500 kbps, 1 Mbps

### ■ Output Items

No.	Item	Expected measurement range	Necessary bytes
1	Rotation speed	0 to 99,999 r/min	4 bytes

### ■ Output Correspondences (Extended ID not Supported)

NO	Format	Endian - Big endian (Motorola)							
	STANDARD_ID	Data Bytes							
1	0x711 Allowed setting range 0x001 to 0x7FF	1	2	3	4	5	6	7	8
		Rotation speed (r/min)				Dummy data			

### ■ Data Format

No.	Data	Type	Description
1	Rotation speed (r/min)	32 bit unsigned integer	Rotation speed (r/min) MAX: 99,999 (r/min) / MIN: 0 (r/min)



# Chapter 5

## Reference Materials

1. Specifications	76
2. Outside Dimension Diagram	80
3. Error Messages and Corrective Actions Taken	81

# 1. Specifications

## 1.1 Display Unit

Display method	Vacuum fluorescent display
Display size	52.5 mm × 11.5 mm
Display Item	Rotation speed (r/min) (average value)
Displayable range	0 to 99,999 r/min
Update interval of display panel	0.1 [s]/0.2 [s]/0.5 [s]/1.0 [s]
Precision	Within $\pm 0.01\%$ /F.S ( $\pm 1$ count) • Factor value: 1.0000E + 0
Display status	SIG IND: Light each time when input signal is detected.

## 1.2 Input

Input connector	BNC/screw-coupling miniature circular multipolar connector (Tajimi Electronics: R03-PB6M)
Applicable sensor	IP-292/296/3000A/3100 OM-1200/1500 VP-202/1220 MP-900 Series/MP-9000 Series/MP-981 LG-9200/930 EXT (PULSE) ECU crank pulse (optional) Lo: 0.8 V or lower, Hi: 4 V or higher
Sensor power supply	12 V $\pm$ 10% (100mA or lower)
Pulse count per revolution (P/R)	0.1 to 1000.0 P/R (set in steps of 0.1 P/R)
Trigger level	0.0 to 100.0 P/R (set in steps of 0.1)

## 1.3 Analog Output

Number of output points	1 (BNC connector)
Output item	Rotation speed (r/min)
Output range	0 to 10 V
Range setting	1 to 99,999 r/min (set in steps of 1 r/min)
Temperature coefficient	$\pm 0.02\%$ F.S./ $^{\circ}\text{C}$

Load resistance (Output impedance)	Approx. 150 $\Omega$
Load resistance (Recommended)	100 k $\Omega$ or higher
Precision (Linearity)	$\pm 0.1\%$ F.S.
Adjustment range (Zero)	Output offset: within $\pm 10$ mV
Update timing	At intervals of 1 pulse/1 ms
Response	Updates in less than 8 $\mu$ s after cycle becomes stable.

## 1.4 Pulse Output

Number of output points	1 (BNC connector)	
Output item	DIRECT	: Wave-shaped output
	0.5 [P/R]	: Output r/min value to obtain 0.5 P/R.
	1 [P/R]	: Output r/min value to obtain 1 P/R.
	60 [P/R]	: Output r/min value to obtain 60 P/R.
Signal level	0 to 5 V logic signal (Lo: 0.4 V or lower, Hi: 4.5 V or higher)	
Load resistance	Output impedance	: Approximately 33 $\Omega$
	Recommended load resistance	: 100 k $\Omega$ or higher

## 1.5 Contact Output

Output detail	Engine run	: 1 to 99999 r/min
	Overrun	: 1 to 99999 r/min
Judgment interval	1 cycle + 100 $\mu$ s or lower	
Contact capacity	30 VDC/0.1 A	
Contact on resistance	30 $\Omega$ or lower	
Leak current with open circuit	10 $\mu$ A or lower	
Hysteresis	0 to 20%	
Connector	Phoenix Contact MVSTBR2,5/4-ST-5,08	

## 1.6 RS-232C

Transfer rate	9600 bps/38400 bps
Connector	HR212-10RA-8SDL circular connector (Hirose Electric) or its equivalent
Dedicated cable	AX-5022
Command function	No writing to non-volatile memory for each condition setting command

## 1.7 CAN (Optional CT-0671 CAN Output)

Output item	Rotation speed (r/min)
Baud rate	125 kbps/250 kbps/500 kbps/1 Mbps
Frequency of updating output	OFF/1 Hz/2 Hz/5 Hz/10 Hz/20 Hz/100 Hz/1 kHz
Connector	D-SUB9-pin (male)



- The CAN setting mode is only available when the optional CT-0671 CAN output is installed.
- For information about options or installation, please contact the nearest Ono Sokki sales office or the distributor where you purchased the product.

## 1.8 Other Functions

Moving average	2 to 720 times
Deceleration calculation	Selection of time or cycle
	Time : 1 to 1200 ms
	Cycle : ×1.5/×3/×5/×8/×16
Trigger assist	Automatic setting of trigger level employed until pulse detection
Resume function	Preserving condition values even while power is off
Condition memory	Maximum of five types of condition memory can be saved.

## 1.9 General Specifications

Termination	Signal ground (connected to cabinet) can be used for signal input (BNC) or signal output (V OUT/P OUT).	
	Signal input (R03) and ground for sensor power supply are isolated from cabinet.	
	Signal input (R03) shell and cabinet are the same.	
Power supply	9 to 28 VDC, 12 VA or lower	
	AC adapter (100 to 240 VAC, 36 VA or lower)	
	Options	LC-0082 power cable for battery (input cable with fuse clips on both ends) LC-0865 power cable for cigarette lighter socket
Outside dimensions	W: 170 H:49 D:120 mm	
Weight	Approximately 700 g	
Operating temperature range	0°C to +50°C (AC adapter operating temperature range: 0°C to +40°C)	
Storage temperature range	-10°C to +60°C	
Operating humidity range	5 to 80% (no condensation)	
Storage humidity range	5 to 85% (no condensation)	
Environmental Conditions	Indoor use only	



Operating Altitude	2000 m maximum	
Safety	IEC61010-1: Overvoltage Category II Protection Class 1 Pollution Degree 2	
Accessories	Rubber feet	x 4
	AC adapter (100 to 240 V) exclusive for 16 VDC batteries	x 1
	Instruction Manual	x 1

## 1.10 Conforming Standards

CE Marking	LVD Directive 2014/35/EU	Standard EN61010-1
	EMC Directive 2014/30/EU	Standard EN61326-1
	RoHS Directive 2011/65/EU	Standard EN50581
FCC	CFR47 Part15 Subpart B Note: This equipment has been tested and found to comply with the limits for a Class A digital device, pursuant to part 15 of the FCC Rules. These limits are designed to provide reasonable protection against harmful interference when the equipment is operated in a commercial environment. This equipment generates, uses, and can radiate radio frequency energy and, if not installed and used in accordance with the instruction manual, may cause harmful interference to radio communications. Operation of this equipment in a residential area is likely to cause harmful interference in which case the user will be required to correct the interference at his own expense.	

For details , see:<https://www.onosokki.co.jp/English/english.htm>

## 1.11 Pulse Count per Revolution (P/R) and r/min Range

### ■ Pulse Count per Revolution (P/R) and r/min Measurement Range

Sensor	Pulse count per revolution (P/R)	r/min measurement range
IP-292/296 ignition pulse detector	0.5 to 8.0	120 to 20000 r/min
IP-3000A/3100 ignition pulse detector		
OM-1200/1500 motor/gasoline engine RPM detector	0.5 to 8.0	120 to 20000 r/min
VP-202/1220 engine vibration detector		
MP-900/9000 series electromagnetic detector	1.0 to 1000.0	30 to 99999 r/min
MP-981 magnetic detector	1.0 to 1000.0	0 to 99999 r/min
LG-9200/930 optical detector	1.0	0 to 99999 r/min
EXT (PULSE)	0.1 to 1000.0	0 to 99999 r/min
Crank angle signal for ECU (optional)	1 to 120.0	120 to 20000 r/min

## 2. Outside Dimension Diagram

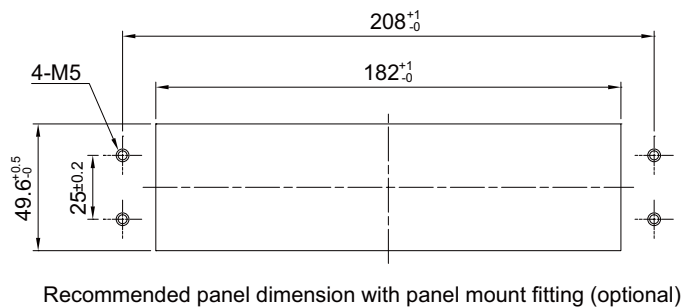
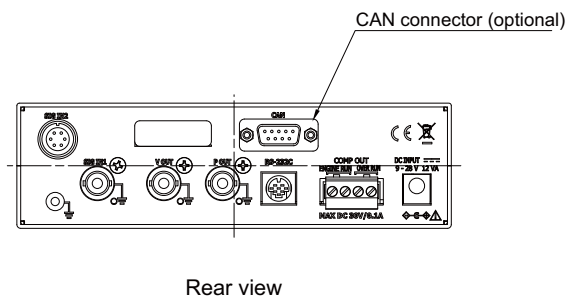
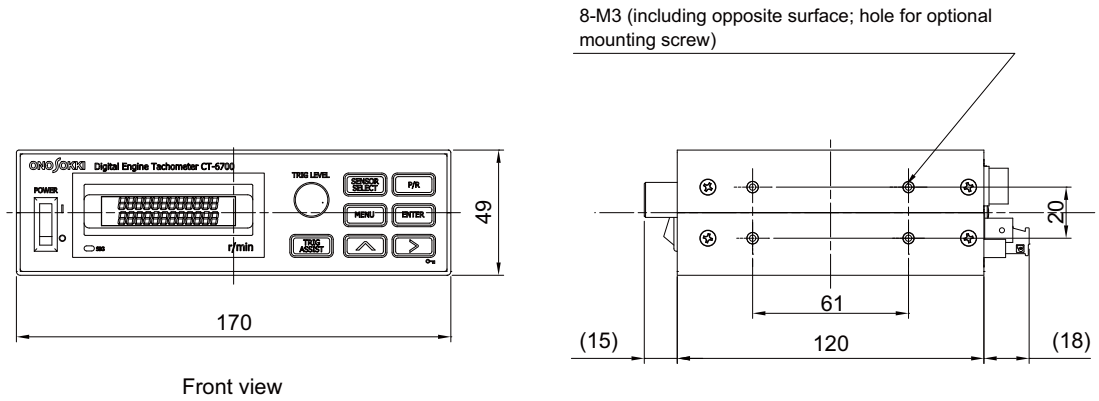

### 3. Error Messages and Corrective Actions Taken

CT-6700 digital engine tachometer displays a message if an error occurs. Take proper action against the error by referring to the corrective actions listed below.



- If the error still persists after you took corrective action according to this list, immediately stop using the tachometer and contact the nearest Ono Sokki sales office or the distributor where you purchased the tachometer.

#### ■ Error messages (critical)

The following error messages will appear if an error occurs in the internal circuit of the CT-6700 digital engine tachometer.

Turn the power off at once and contact the nearest Ono Sokki sales office or the distributor where you purchased the product.

Message	Message text	Cause
BOOT ERROR! MEM CLEAR? (0: NO/1: YES)	Boot error of FPGA. Data read error.	Value read of the magic number of FPGA specified area is inappropriate.
MEMORY ERROR! MEM CLEAR?	Condition memory error.	Incorrect checksum of memory at start up. <ul style="list-style-type: none"> <li>• Pressing the ENTER switch clears the condition memories and starts the normal operation. In this operation, the analog output calibration values are cleared, which need to be calibrated again. For details of the calibration, refer to "2.10 Setting Calibration Conditions (8: CAL)" on page 60.</li> </ul>

#### ■ Error message (general)

The following messages will appear if you set inappropriate conditions. Set inappropriate conditions according to the procedure for taking corrective actions.

Message	Message text	Cause	Corrective action
FREQUENCY OVER! ****r/min	Frequency over error.	This message appears when the r/min calculation results exceeds the [maximum usable frequency 120kHz*1.0125]. The error message disappears automatically.	Verify the input signal, and reset each condition for LPF and PR appropriately.
DISPLAY OVER! 99,999 r/min	Displayed number exceeds the specified number of digits.	This message appears when the r/min calculation results exceeds 99,999 r/min. The error message disappears automatically.	Verify the input signal, and reset each condition for LPF and PR appropriately.
RANGE OVER! ****r/min	Displayed number exceeds the specified range.	This message appears when the r/min calculation results exceeds range condition value *1.0125. The error message disappears automatically.	Reset the set conditions for range, factor and PR appropriately.
TRIG ASSIST ERROR ENTER	Automatic adjustment of trigger level using the Trigger assist mode failed.	This message appears when automatic trigger level adjustment using Trigger assist mode was not completed normally.	Press the ENTER switch to return to the Measurement mode. Verify the input signal and reset the gain condition value.

Message	Message text	Cause	Corrective action
CRANK PULSE CAL ER-ROR ENTER	Automatic setting of crank pulse failed.	of This message appears when automatic setting of crank pulse was not completed normally. <ul style="list-style-type: none"> <li>This function is only available when the optional CT-0672 ECU crank pulse input is installed.</li> </ul>	Press the ENTER switch to return to the Measurement mode. Verify the input signal or crank (number and position of missing or increasing gear teeth) and reset the set conditions appropriately.

### ■ Initialization Procedure

The conditions that have been set for the CT-6700 digital engine tachometer can be reset to the factory default setting (initialization).

The initialization procedure is as follows:

- While pressing the TRIG ASSIST and P/R switches at the same time, change the power switch of the CT-6700 digital engine tachometer to ON ( I ).  
 Message "MEMORY CLEAR?" is displayed, asking you whether you are executing or canceling initialization.
- Execute the initialization.  
 Select "1: YES" by using the Up (^) switch and press the ENTER switch to start initialization.  
 When the initialization is completed, the CT-6700 digital engine tachometer is reset to the factory default setting.  
 To cancel the initialization, select "0: NO" by using the Up (^) switch and then press the ENTER switch.

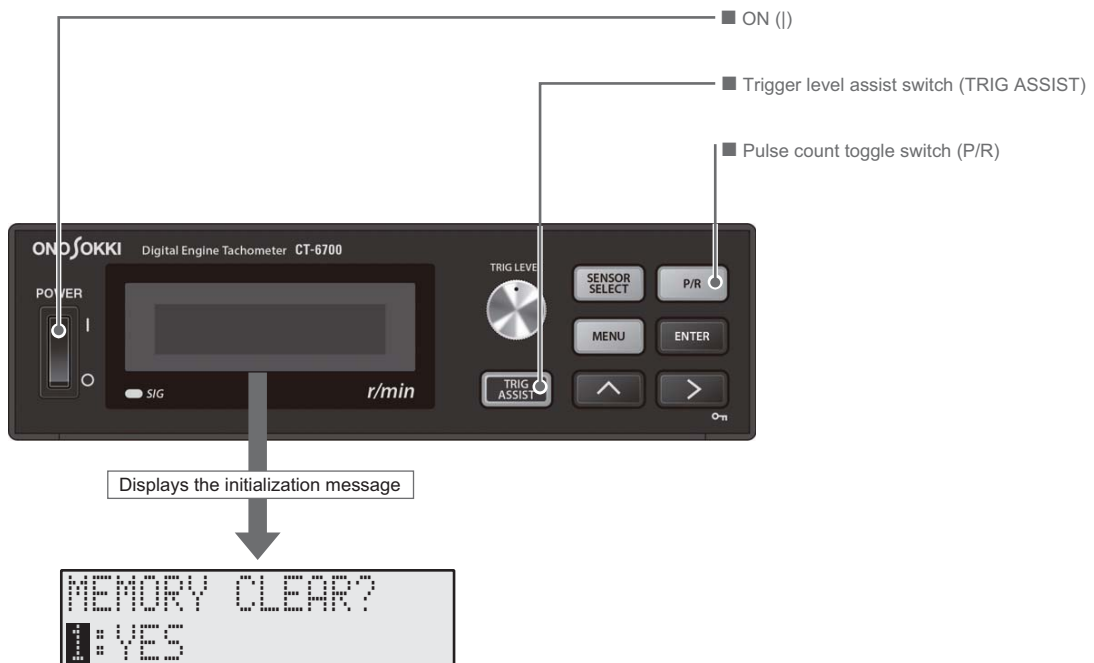

- Even when initialization is executed, the data stored in the condition memory is not initialized.
- Note that once the initial reset (initialization to default settings) is executed, the current settings are deleted and it is not possible to restore them. If you need the current conditions, save them in the condition memory before executing initialization.

---

# Index

## A

Adjusting trigger level.....	37
Adjusting trigger level and confirming operation.....	37
Analog output.....	76
Applicable sensor.....	19

## B

Bar graph.....	16
Branching a cable.....	31

## C

Calculation rotation speed.....	16
CAN: CAN connector (optional).....	13
CAN data format.....	73
CAN interface.....	71
CAN (Optional CT-0671 CAN output).....	78
CAN system configuration.....	71
CAN connector specifications.....	71
CAN connector pin assignment.....	72
Changing setting condition and confirmation operation.....	43, 44
Checking supplied items.....	5
Component names and functions.....	11
Component names and functions of measurement mode screen.....	16
Component names and functions of utility area and tool area.....	29
Component names of menu mode screen.....	17
COMP OUT (ENGINE RUN/OVER RUN): Comparator contact output terminal.....	14
Conforming Standards.....	79
Connecting power supply.....	26
Connecting sensors to the CT-6700.....	31
Connecting to peripheral units.....	32
Connecting to P-OUT (pulse signal output connector).....	33
Connection power supply from battery.....	26
Connection to V-OUT (Voltage Output Connector).....	33
Connection via cigar lighter socket.....	27
Contact output.....	77
CT-0671.....	20
CT-0672.....	20
CT-0673.....	20
CT-0674.....	20
CT-0675.....	20
CT-0676.....	20
CT-6700 screens.....	15

---

<b>D</b>	
Data format.....	73
DC INPUT: DC INPUT connector.....	14
Deceleration condition setting function.....	51
Detecting with engine vibration.....	29
Detecting with EV/HEV motor and alternator.....	29
Detecting with gasoline engine (Direct ignition).....	28
Detecting with gasoline engine (Distributor type).....	28
Detecting with gears attached to the rotating body.....	30
Detecting with reflector attached to the rotating body.....	30
Detecting with signal between crank angle sensor and ECU.....	30
Direct ignition type.....	36
Disabled display.....	16
Disconnecting peripherals.....	40
Disconnecting power supply.....	34
Display panel (fluorescent display tube).....	11
Display unit.....	76
Distributor type.....	36
<b>E</b>	
ECU crank pulse calibration mode (CRANK PULSE CAL).....	46
ENTER: ENTER switch.....	12
Error codes.....	65
Error message.....	16
Error message (critical).....	81
Error message (general).....	81
Error messages and corrective actions.....	81
ECU crank pulse automatic setup screen (1: AUTO).....	47
ECU crank pulse manual setting screen (2: GEAR NUM SET).....	47
Example of measurement system configuration of CT-6700 and peripherals.....	18
External view and pin arrangement of RS-232C.....	64
External view and specifications of CAN connector.....	71
External view and specifications of RS-232C connector.....	64
<b>F</b>	
Features.....	10
Finishing measurement.....	40
For your safety.....	2
From installation to complete measurement.....	23
Front panel.....	11
Functional grounding terminal.....	13
<b>G</b>	
General specifications.....	78
<b>H</b>	

---

How to use this manual .....	1
Hysteresis mechanism .....	53
<b>I</b>	
Initialization procedure .....	82
Input .....	76
Installation .....	23
Installing and connecting the sensor .....	28
Interface reference .....	63
Introduction.....	1
<b>J</b>	
Judgment mechanism and examples.....	53
<b>K</b>	
Key protection symbol.....	16
Key protect switch .....	12
<b>L</b>	
LC-0082.....	20
LC-0865.....	20
List of menu structure.....	48
List of preset pulse counts for gasoline engine .....	36
<b>M</b>	
Manual trigger level adjustment .....	38
Meanings of symbols.....	2
Measuring procedure with CT-6700 .....	22
Measuring with the alternator .....	29
Menu mode .....	17
Menu reference .....	48
MENU: MENU switch .....	12
Mode and menu references .....	41
Mode controllers.....	42
Mode screen reference .....	42
Mounting on a desk.....	23
Mounting on a panel.....	25
Mounting on a vehicle .....	23
<b>N</b>	
Notice about electromagnetic environment.....	3
<b>O</b>	
Optional equipment.....	20
Other functions.....	78
Output correspondences (Extended ID not supported).....	73

Output items .....	73
Output rate specifications.....	73
Outside dimensions.....	80
Overview and features .....	10
Overview and features of CT-6700.....	10
Overview of CAN.....	71
Overview of CAN interface.....	71
Overview of CT-6700.....	9
Overview of menu mode screen.....	42
Overview of RS-232C.....	64
Overview of RS-232C interface.....	64

## P

P OUT: P OUT connector .....	14
POWER: power switch.....	11
Precautions for Power Supply.....	3
Precautions on Disposal.....	3
Precautions on storage .....	31
Precautions on Storage.....	4
Precautions on Usage .....	2
Precautions on Use .....	3
Precautions when mounting optional detectors.....	4
Preparation and Measurement of CT-6700.....	21
Procedures for automatic adjustment of trigger level in the trigger assist mode.....	38
P/R: P/R switch .....	12
Pulse Count per Revolution (P/R) and r/min Measurement Range.....	79
Pulse count per revolution (P/R) and r/min range .....	79
Pulse output .....	77
Pulse setup mode (P/R) .....	45

## R

Rear panel.....	13
Recommended circuit for comparator contact output terminal.....	33
Recommended circuit for output connector.....	33
Recommended circuit for pulse connector .....	33
Reference materials .....	75
Removing and storing the equipment.....	40
Removing power supply .....	40
Removing the sensor .....	40
RIGHT ARROW (>) switch .....	12
RS-232C.....	77
RS-232C command reference.....	66
RS-232C interface.....	64
RS-232C: RS-232C connector .....	14
RS-232C system configuration.....	64

## S

Safety symbols .....	2, 31
----------------------	-------



---

Safety symbols and caution labels .....	4
Screen transition of trigger assist mode .....	46
Selecting a sensor in the sensor select mode (SENSOR SELECT) .....	34
Sensor select mode (SENSOR SELECT) .....	45
SENSOR SELECT: SENSOR SELECT switch .....	12
Setting baud rate conditions for CAN output signal (0: BAUDRATE) .....	61
Setting baud rate (transmission speed) conditions (0: BAUDRATE) .....	58
Setting brightness conditions for fluorescent tube (1: BRIGHT) .....	57
Setting calibration conditions (8: CAL) .....	60
Setting CAN output conditions (9: CAN-OUT) .....	61
Setting comparator output conditions (4: COMP-OUT) .....	53
Setting data display update time conditions (0: UPDATE) .....	56
Setting deceleration conditions (4: REDUCE) .....	51
Setting delete conditions of condition memory (0: CLEAR) .....	60
Setting display conditions for fluorescent tube (5: DISPLAY) .....	56
Setting display mode for measurement screen (2: MODE) .....	57
Setting engine run conditions (0: ENGINE RUN) .....	54
Setting engine run contact mode conditions (1: MODE) .....	54
Setting engine run judgment conditions (0: VALUE) .....	54
Setting factor conditions (2: FACTOR) .....	50
Setting FULL conditions for calibration signal output (1: FULL) .....	60
Setting gain conditions (1: GAIN) .....	50
Setting general condition in sensor select mode and pulse setup mode .....	34
Setting hysteresis conditions (2: HYSTERESIS) .....	55, 56
Setting ID conditions for CAN output signal (1: ID) .....	61
Setting INVERT conditions (0: INVERT) .....	52
Setting load conditions of condition memory (1: LOAD) .....	59
Setting measurement conditions (1: MEAS) .....	49
Setting memory conditions (7: COND MEMORY) .....	59
Setting moving average conditions (3: AVERAGE) .....	50
Setting operation for conditions and values in menu mode .....	42
Setting other conditions .....	36
Setting output update frequency conditions for CAN output signal (2: UPDATE) .....	62
Setting overrun conditions (1: OVER RUN) .....	55
Setting overrun contact mode conditions (1: MODE) .....	55
Setting overrun judgment conditions (0: VALUE) .....	55
Setting pulse count in pulse setup mode (P/R) .....	35
Setting pulse output conditions (2: P-OUT) .....	52
Setting range conditions (0: RANGE) .....	49
Setting RS-232C interface conditions (6: RS-232C) .....	58
Setting RS232C mode conditions (1: MODE) .....	58
Setting save conditions of condition memory (0: SAVE) .....	59
Setting terminal resistance conditions for CAN output signal (3: TERM) .....	62
Setting voltage output conditions (3: V-OUT) .....	52
Setting ZERO conditions for calibration signal output (1: ZERO) .....	60
SIG IN 1: SIG IN1 connector .....	13
SIG IN 1 connector pin assignment .....	32
SIG IN 2: SIG IN2 connector .....	13
SIG IN 2 connector pin assignment .....	32

---

SIG: Signal indicator.....	11
Software version information (0: VERSION) .....	49
Specifications .....	76
Specifications of RS-232C .....	65
Starting and finishing measurement.....	39
Starting measurement .....	39
Supplied items.....	5
System configuration.....	18

## T

TRIG ASSIST: TRIG LEVEL ASSIST switch .....	12
Trigger assist mode (TRIG ASSIST) .....	46
Trigger assist mode (TRIG ASSIST) and ECU crank pulse calibration mode.....	17
Trigger level setup mode screen (TRIG) .....	45
Trigger level setup mode (TRIG).....	17
TRIG LEVEL: TRIGGER LEVEL ADJUSTMENT dial.....	11
Type 1.....	65
Type 1: Read status commands.....	66
Type 2.....	65
Type 2: Execution commands .....	66
Type 3.....	65
Type 3: Set and read condition commands.....	67
Type and display items of screen .....	15
Types of commands .....	65

## U

UPWARD ( ) switch .....	12
Using AC adapter .....	26
Using the Car Battery .....	26

## V

V-OUT: V OUT connector .....	14
------------------------------	----

## W

Working mechanism of comparator output.....	53
---	----



# ONOSOKKI

\*Outer appearance and specifications are subject to change without prior notice.

**HOME PAGE:** <https://www.onosokki.co.jp/English/english.htm>

---

**WORLDWIDE**

ONOSOKKI CO., LTD.

1-16-1 Hakusan, Midori-ku,

Yokohama 226-8507, Japan

Phone : +81-45-935-3918

Fax : +81-45-930-1808

E-mail : [overseas@onosokki.co.jp](mailto:overseas@onosokki.co.jp)

B00002534 / IM16040101(1.0)