

PCE Americas Inc.  
711 Commerce Way  
Suite 8  
Jupiter  
FL-33458  
USA  
From outside US: +1  
Tel: (561) 320-9162  
Fax: (561) 320-9176  
info@pce-americas.com

PCE Instruments UK Ltd.  
Units 12/13  
Southpoint Business Park  
Ensign way  
Hampshire / Southampton  
United Kingdom, SO31 4RF  
From outside UK: +44  
Tel: (0) 2380 98703 0  
Fax: (0) 2380 98703 9  
info@pce-instruments.com

[www.pce-instruments.com/english](http://www.pce-instruments.com/english)  
[www.pce-instruments.com](http://www.pce-instruments.com)

## MANUAL Air Humidity Meter PCE-320



---

## **INTRODUCTION**

**Thank you for purchase of the Psychrometer with IR Thermometer. This device offers non-contact (infrared) temperature measurements capability. The built-in laser pointer increases target accuracy while the backlight LCD and handy push-buttons combine for convenient, ergonomic operation. Type K thermocouple functionality and Humidity & Temperature Sensor of highest reliability and excellent long term stability are also built-in.**

**Proper use and care of this meter will provide years of reliable service.**

---

## **1.Features:**

- 1. 3 in professional measuring instrument: Type k, IR and Psychrometer.**
- 2. Triple digital LCD display.**
- 3. Built-in microprocessor circuit assures excellent performance and accuracy.**
- 4. Fast response,all the data calculated four times in one second.**
- 5. Standard type k(NiCr-NiAl) Thermocouple input jack suitable for all kinds of type k probe.**
- 6. Infrared to measure surface temp.**
- 7. Red laser indicator included.**
- 8. LCD With Backlight**
- 9. Automatic range selection**
- 10. USB interface.**
- 11. Low battery indication.**
- 12.Auto Power off.**
- 13. Handheld size,easy to carry.**

---

## **WIDE RANGE APPLICATION:**

Food preparation, Safety and Fire inspectors, Plastic molding, Asphalt, Marine and Screen printing, measure ink and Dryer temperature, HVAC/R, Diesel and Fleet maintenance.

### 1. **SAFETY**

- Use extreme caution when the laser beam is turned on.
- Do not let the beam enter your eye, another person's eye or the eye of an animal.
- Be careful no to let the beam on a reflective surface strike your eye.
- Do not allow the laser light beam impinge on any gas which can explode

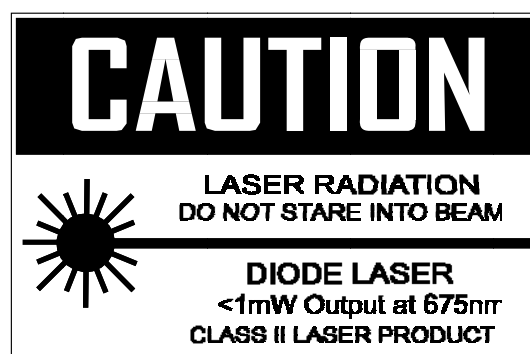

## Distance & Spot Size

As the distance (D) from the object increases, the spot size (S) of the area measured by the unit becomes larger. The relationship between distance and spot size for each unit is listed below. The focal point for each unit is 914mm (36"). The spot sizes indicate 90% encircled energy.

Fig: 1

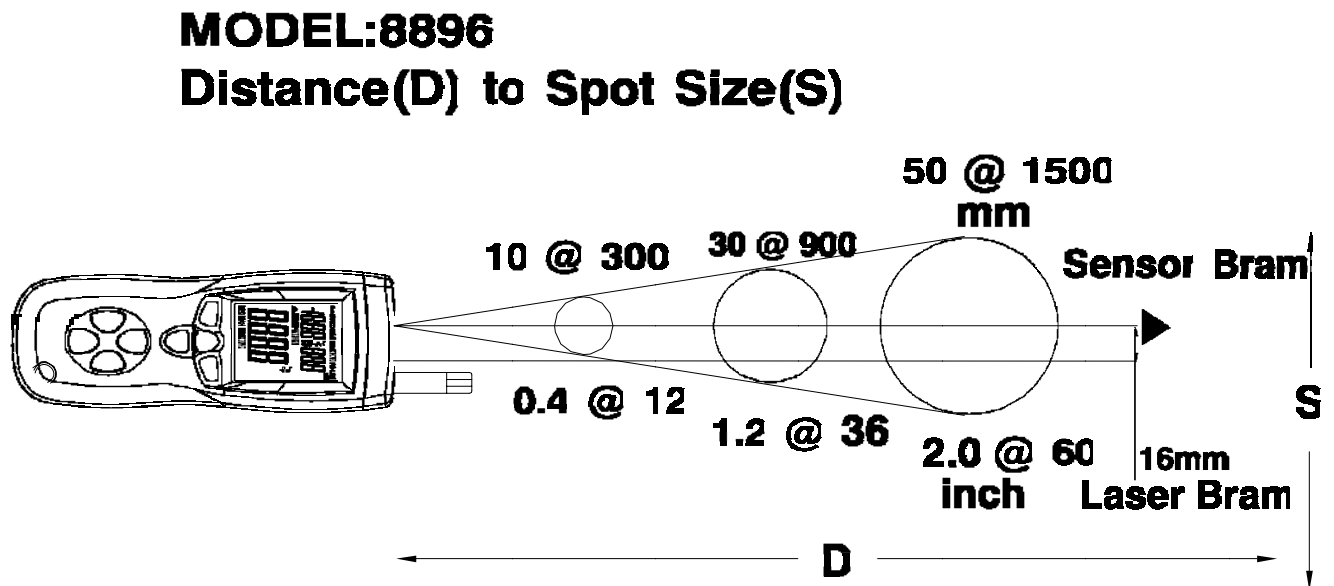

## 2. Specifications:

Function	Range	Resolution	Accuracy
Type k Temp.	-148~2501°F (-100~1372°C)	0.1°F/°C	± (1% ±1°C)
InfraRed Temp.	-58 to~4°F (-50~ -20°C)	0.1°F/°C	±9.0°F (5.0 °C)
	-4 to932°F (-20~500°C)	0.1°F/°C	±2% reading or ±4°F (2°C)
Air Temp.	-4-140°F (-20~60°C)	0.1°F/°C	±2.0°F (1.0 °C)
Humidity	10%~90%	0.1%RH	±2%
	others	0.1%RH	±3%
Wet Bulb	-6.88~140°F (-21.6~60°C)	0.1°F/°C	
Dew Point	-90.4 - 140°F (-68 - 60°C)	0.1°F/°C	
Dimensions:	257 x 76 x 53(mm)		
Display size:	42.4 x 56.4(mm)		
Whight:	355(g)		

### 3. Frontpane Description:

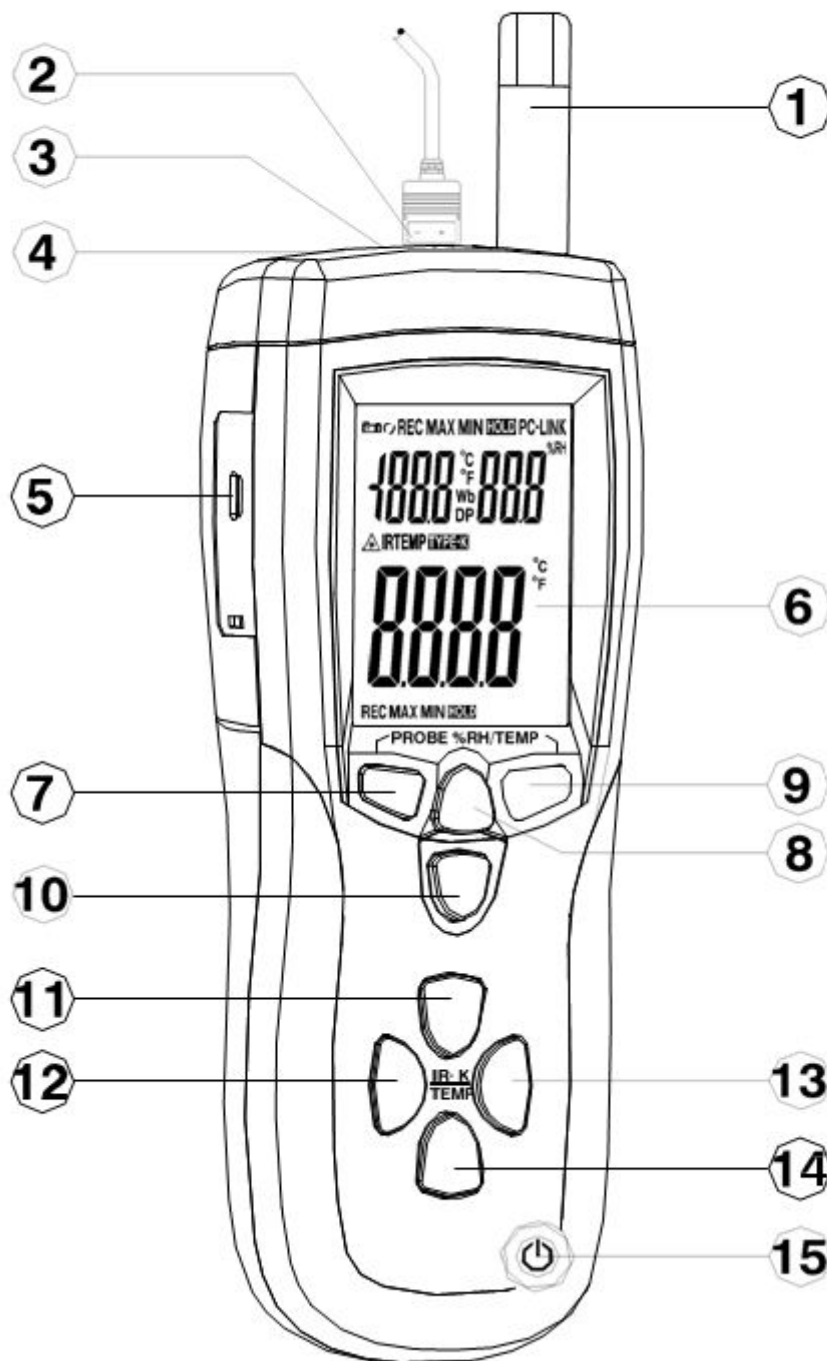

1. Humidity & Temperature Sensor
2. Thermocouple input jack
3. Laser pointer beam
4. Laser sensor
5. USB Interface
6. LCD Display
7. Humidity & Temperature Sensor Max/Min Button
8. TEMP./Wet Bulb/Dew Point Button
9. TEMP./Wet Bulb/Dew Point/%RH hold Button
10. IR Measurement Trigger
11. °F/°C Button
12. IR OR Type K Max/Min Button
13. IR OR Type K Hold Button
14. Backlight Button
15. Power Button



## Indicator:

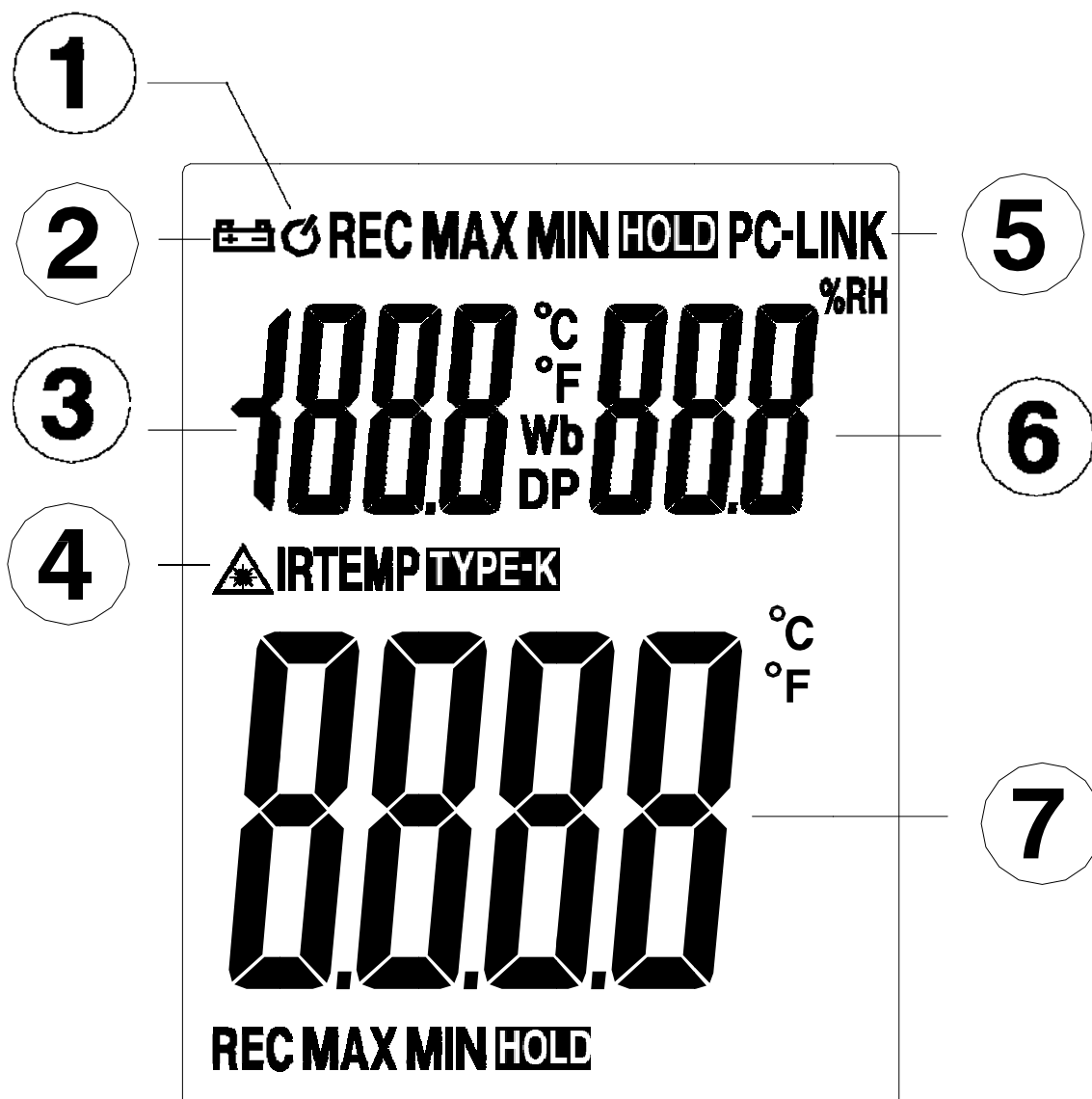

- ① Auto Power Off Indication
- ② Battery Indication
- ③ Air Temp. Value
- ④ IR Temp./Type K Temp. Indication
- ⑤ Communication Indication
- ⑥ Air Humidity
- ⑦ IR Temp./Type K Temp. Value

---

## 4.Operation:

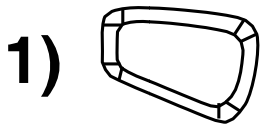

### **Air Humidity and temp. MAX,MIN, Recording Function.**

- Press the **Max/Min** button to begin capturing the Minimum and Maximum values, The 'REC' icon will appear on the upper left corner of the display.
- Press the **Max/Min** to view maximum and minimum recorded readings.
- Press and Hold the **Max/Min** button until the display returns to standard operation to exit the **Max/Min** function and the “**REC**” icon on the upper left corner will disappear.



Press to select the operation mode from air temperature ,dew point and web bulb.

---

3) 

- Press the **HOLD** button to freeze Air Humidity and temp. reading in the upper half display, The '**HOLD**' icon will appear on the upper right corner of the display. Press the **HOLD** button again to return to normal operation and the '**HOLD**' icon will disappear.

4) 

- Press to measure surface temp. By activating IR function.  
- Released to hold the surface temperature value 10 second, and later change to measure type k temp.

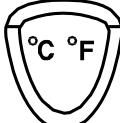
5) 

- Press to change temperature unit.

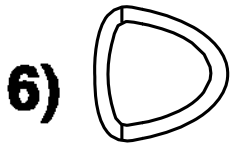

6)

## IR temp. or Type k MAX,MIN, Recording Function.

- Press the **Max/Min** button to begin capturing the Minimum and Maximum values, The 'REC' icon will appear on the lower left corner of the display.
- Press the **Max/Min** to view maximum and minimum recorded readings.
- Press and Hold the **Max/Min** button until the display returns to standard operation to exit the Max/Min function and the “**REC**” icon on the lower left corner will disappear.

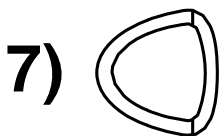

7)

- Press the HOLD button to freeze IR or type k temp. reading in the lower half display, The 'HOLD' icon will appear on the lower of the display. Press the HOLD button again to return to normal operation and the 'HOLD' icon will disappear.

8) 

- Press the button to turn the meter on or off.

**5.Auto Power OFF:**

- The meter will automatically turn off after 15 minutes if no keys are pressed during this period.

**6. Bypass Auto Power Off:**

The meter will automatically turn off after 15 minutes in the normal. When you turn on

the meter, and press the button  first,an “disAP0” appears on the LCD,then you can release the button and the automatic power off feature will be disabled.

**7.Low Battery:**

If the battery indicator appear on the upper left corner of the display,indicates battery is low.Please replace with a 9 volt battery.

---

## **8.Warranty:**

The meter is warranted to be free from defects in material and workmanship for a period of one year from the date of purchase. This warranty covers normal operation and does not cover batter, misuse ,abuse ,alteration ,tampering ,neglect ,improper maintenance or damage resulting from leaking batteries. Proof of purchase is required for warranty repair. Warranty is void if the meter has been opened.