

3300C Mainframe Operation Manual

Material Contents Declaration

(材料含量宣称)

(Part Name) 零件名称	Hazardous Substance (有毒有害物质或元素)					
	铅 (Pb)	汞 (Hg)	镉 (Cd)	六价铬 (Cr6+)	多溴 联苯 (PBB)	多溴 二苯醚 (PBDE)
PCBA (印刷电路装配件)	X	0	X	0	0	0
Electrical part not on PCBA's 未在PCBA上的电子零件	X	0	X	0	0	0
Metal parts 金属零件	0	0	0	X	0	0
Plastic parts 塑料零件	0	0	0	0	X	X
Wiring 电线	X	0	0	0	0	0
Package 封装	X	0	0	0	0	0

对销售之日的所售产品,本表显示, PRODIGIT 供应链的电子产品信息产品可能包含这些物质。注意:在所售产品中可能会也可能不会含有所有所列的部件。This table shows where these substances may be found in the supply chain of Prodigit electronic information products, as of the date of sale of the enclosed product. Note that some of the component types listed above may or may not be a part of the enclosed product. 0: 表示该有毒有害物质在该部件所有均质材料中的含量均在SJ/T 11363-2006 标准规定的限量要求以下。0: Indicates that the concentration of the hazardous substance in all homogeneous materials in the parts is below the relevant threshold of the SJ/T 11363-2006 standard. X: 表示该有毒有害物质至少在该部件的某一均质材料中的含量超出SJ/T 11363-2006 标准规定的限量要求。X: Indicates that the concentration of the hazardous substance of at least one of all homogeneous materials in the parts is above the relevant threshold of the SJ/T 11363-2006 standard.

Note(注释):

1. Prodigit has not fully transitioned to lead-free solder assembly at this moment ; However, most of the components used are RoHS compliant.

(此刻, Prodigit 并非完全过渡到无铅焊料组装;但是大部份的元器件一至于RoHS的规定。)

2. The product is labeled with an environment-friendly usage period in years.

The marked period is assumed under the operating environment specified in the product specifications.

(产品标注了环境友好的使用期限(年)。所标注的环境使用期限假定是在此产品定义的使用环境之下。)



Example of a marking for a 10 year period:

(例如如此标制环境使用期限为10年)

3300C Series Mainframe Operation Manual

Table of Contents

Chapter 1 Introduction	1-1
1.1 Features.....	1-1
1.2 Option	1-2
1.3 Specifications.....	1-2
1.4 System block diagram.....	1-3
Chapter 2 Installation	2-1
2.1 Inspection.....	2-1
2.2 Check line voltage.....	2-1
2.3 Grounding requirements	2-2
2.4 Adjust the feet.....	2-2
2.5 Rack mount.....	2-2
2.6 Environmental requirements	2-2
2.7 Observe the International Electrical Symbol listed below.....	2-2
2.8 Cleaning and Storage	2-3
2.9 Repairing.....	2-3
2.10 Accessories	2-3
2.11 GPIB connection.....	2-3
2.12 RS-232C Connection.....	2-4
2.13 Remote control Port.....	2-4
2.14 Analog programming input.....	2-4
Chapter 3 Mainframe operation	3-1
3.1 Feet stands	3-1
3.2 Power switch.....	3-1
3.3 Power on status	3-1
3.4 STORE / RECALL operation.....	3-2
3.5 AUTO SEQUENCE testing function description.....	3-4
Chapter 4 GPIB/RS-232 programming operation	4-1
4.1 Introduction	4-1
4.2 The summary of GPIB command.....	4-1
4.3 The summary of RS-232 interface and command.....	4-1
4.4 GPIB/RS-232C COMMAND LIST	4-3
4.5 The description of abbreviation	4-9
4.6 GPIB/RS-232 command description	4-10
Appendix A GPIB programming Example	A-1
Appendix B RS-232 programming Example	B-1
Appendix C 3250A Series GPIB/RS-232 Operating flow chart	C-1
Appendix D 3310A Series GPIB/RS-232 Operating flow chart	D-1
Appendix E 3330A Series GPIB/RS-232 Operating flow chart	E-1
Appendix F 3310C Series GPIB/RS-232 Operating flow chart	F-1

Figures

Fig 1-1 BLOCK DIAGRAM	1-3
Fig 2-1 SET OF SWITCH	2-1
Fig 2-2 AC LINE RECEPTACLE.....	2-2
Fig 2-3 3300C REAR PANEL	2-3
Fig 2-4 Diagram of Remote Control Port	2-4
Fig 2-5 Diagram of analog programming input	2-4
Fig 3-1 3300C FRONT PANEL.....	3-1
Fig 3-2 3300C front panel key switch	3-2
Fig 3-3 AUTO SEQ function operation flow chart	3-4
Fig 3-4 STORE (EDIT) MODE OPERATIONO FLOW-CHART	3-5
Fig 3-5 TEST MODE OPERATION FLOW-CHART.....	3-6
Fig 4-1 RS-232 INTERFACE DIAGRAM	4-2

Tables

TABLE 1-1 3250A/3310A/3310C/3330A SERIES SIMPLE SPECIFICATION LIST	1
TABLE 1-2 SPECIFICATIONS	2
TABLE 4-1 GPIB/RS-232 SETTING COMMAND SUMMARY.....	3
TABLE 4-2 GPIB/RS-232 QUERY COMMAND SUMMARY	4
TABLE 4-4 GPIB COMMAND TERMINATOR.....	9
TABLE 4-5 WAVEFORM INFORMATION.....	17
TABLE 4-6 RANGE I/II FULL SCALE CURRENT FOR 3310 SERIES LOAD	23
TABLE 4-7 PROT STATUS BYTE REGISTER	29

Chapter 1 Introduction

The 3300C Electronic load mainframe is designed to install to the single channel 3250A/ 3310A/ 3310C/ 3330A series plug-in load module, 3250A/ 3310A/ 3310C/ 3330A series plug-in module simple specification as table 1-1. Please contact your local PRODIGIT distributor or PRODIGIT sales dept. for detail specification.

Model	Max. current	Max. voltage	Max. power
3250A	20 Arms	60 Vrms	300 W
3251A	8 Arms	150 Vrms	300 W
3252A	4 Arms	300 Vrms	300 W
3253	1Arms	300 Vrms	300 W
3310C	30A	60V	150W
3311C	60A	60V	300W
3312C	10A	250V	300W
3314C	5A	500V	200W
3315C	15A	60V	75W
3310A	30 A	60 V	150 W
3311A	60 A	60 V	300 W
3312A	10 A	250 V	300 W
3314A	5 A	500 V	200 W
3315A	15 A	60 V	75 W
3330A	50A/5A	+60V/+60V	250W/50W
3331A	50A/5A	+60V/-60V	250W/50W
3332A	5A/5A	+60V/+60V	75W/75W
3333A	5A/5A	+60V/-60V	75W/75W
3334A	5A/5A	-60V/-60V	75W/75W
3335A	100A/5A	+60V/+60V	500W/50W

TABLE 1-1 3250A/3310A/3310C/3330A SERIES SIMPLE SPECIFICATION LIST

1.1 Features

3300C mainframe provides high performance easy operation and cost effective solution for power source testing, the features of the 3300C electronic load mainframe is described in the following:

- 1.1.1 Plug-in design, it is easy to replace different specifications load module.
- 1.1.2 Flexible configuration, each slot of 3300C mainframe can be installed one of 3250A, 3310A, 3310C or 3330A series load module.
- 1.1.3 RS-232 connector provides RS-232 interface for remote control, it can be used to connect NOTEBOOK PC with RS-232 interface.
- 1.1.4 Four analog programming BNC input on the rear panel can control the four load module's load current with an arbitrary waveforms.
- 1.1.5 Built-in GPIB interface, one GPIB address can control up to four electronic load modules with set load status and read back meter capabilities.

1.2 Option

1.2.1	GPIB interface	
1.2.2	GPIB cable	1 M
1.2.3	GPIB cable	2 M
1.2.4	9931C Remote Controller	1 Set
1.2.5	D-SUB 9 Pin to D-SUB 9 Pin cable	1 M
1.2.6	IEEE-488 Interface Card	1 Pc

1.3 Specifications

The detail specification of 3300C mainframe is shown in Table 1-2.

AC INPUT	LINE	100V/115V±10%	200V/230V±10%
	FREQUENCY	50/60 HZ	
	FUSE	2A/250V (5*20mm)	1A/250V (5*20mm)
	MAX. POWER CONSUMPTION	100 W	
DIMENSIONS (W*H*D)		440 mm*177 mm*445 mm	
WEIGHT		NET : 9.3 Kg	

TABLE 1-2 SPECIFICATIONS

1.4 System block diagram

The system block diagram is shown in Fig 1-1, there are five power supplies in 3300C mainframe one for 3300C mainframe, and others are for each channel respectively. The 3300C mainframe is optically isolated with each load module.

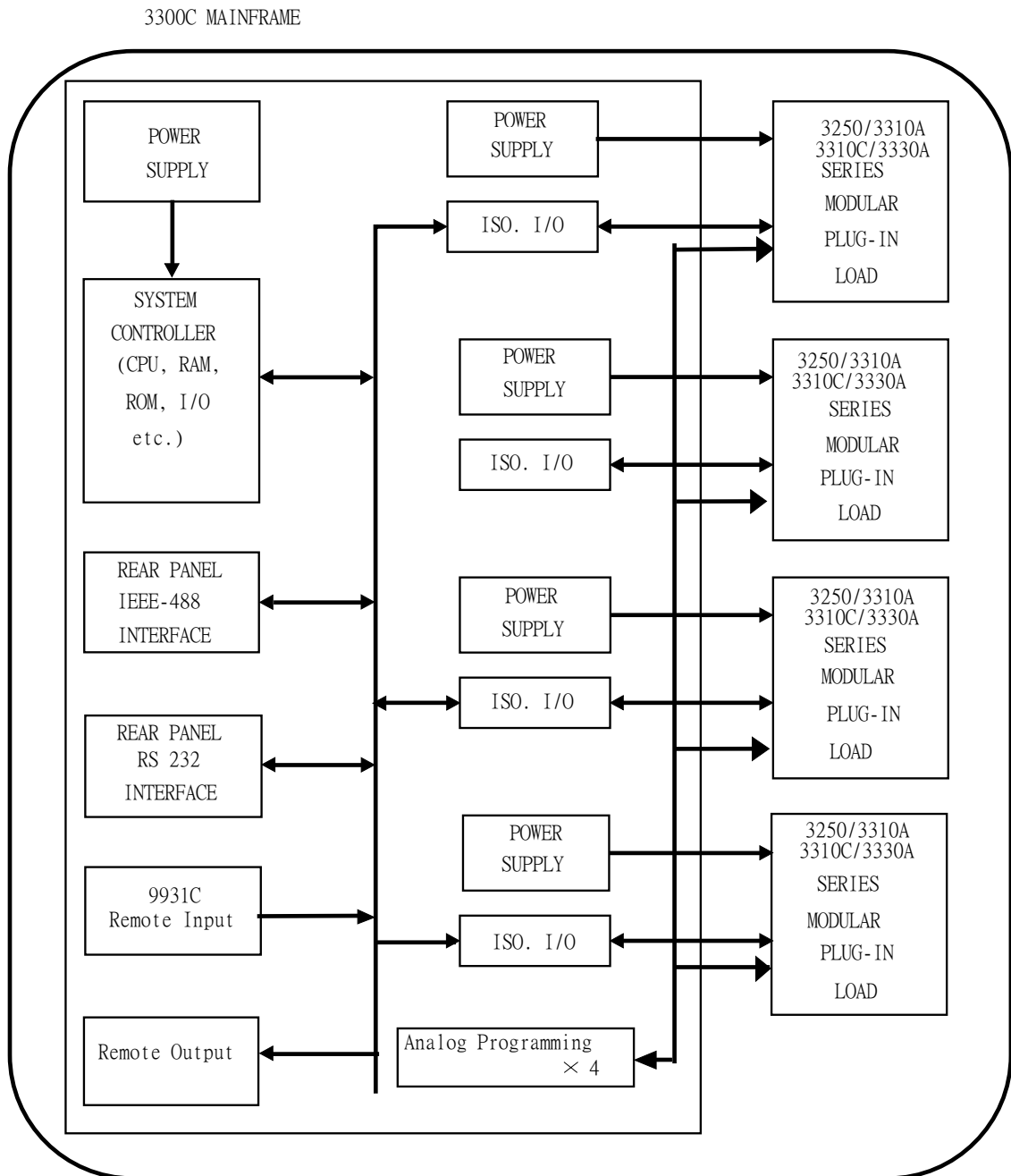

Fig 1-1 BLOCK DIAGRAM

Chapter 2 Installation

2.1 Inspection

The 3300C mainframe was carefully inspected before shipment. If instrument damage has occurred during transport, please inform Prodigit's sales and service office or representative. Your 3300C mainframe was shipped with a power cord for the type of outlet used at your location. If the appropriated cord was not included, please contact your nearest Prodigit sales office to obtain the correct cord. Refer to " check line voltage " to check the line voltage selection and fuse type.

2.2 Check line voltage

The 3300C mainframe and 3250A/3310A/3310C/3330A series electronic load can operation with 100, 115, 200, 230Vac input as indicated on the label on the rear panel. Make sure that the factory check marks correspond to your nominal line voltage. Skip this procedure if the label is corrected marked.

2.2.1 With the 3300C mainframe power OFF, disconnect the power cord.

2.2.2 Refer the drawing on the rear panel in Fig 2-1, set the switches to the proper voltage as describe in the following:

a. Set Switch to 100V/115V for 100Vac or 115Vac line voltage

b. Set Switch to 200V/230V for 200Vac or 230Vac

Note: 100Vac and 200Vac is used for Japan only

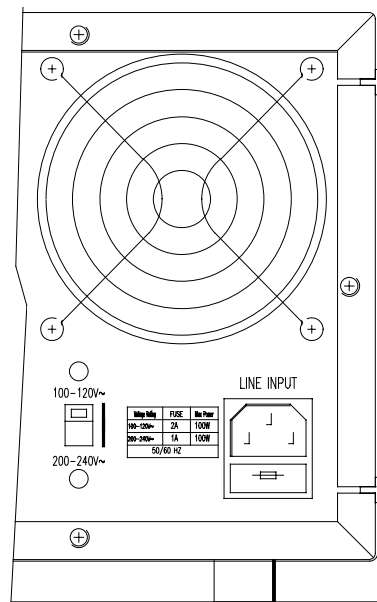

Fig 2-1 SET OF SWITCH

- 2.2.3 Check the rating of the line fuse and replace it with the correct fuse if necessary.
- 2.2.4 The AC line fuse is located below the AC line receptacle see Fig 2-2. With the power cord removed, use a small screwdriver to extract the fuse holder from under the AC socket. Replace the fuse with the appropriate type as indicated in Table 1-2. These fuses are normal-blow fuses.
- 2.2.5 Reinstall fuse holder and connect the power cord.

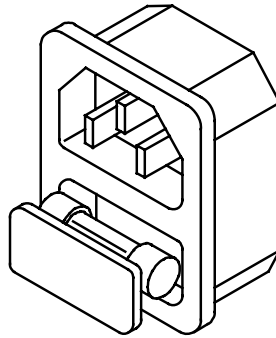

Fig 2-2 AC LINE RECEPTACLE

2.3 Grounding requirements

Model 3300C mainframe and 3250/3310A/3310C/3330A series Plug-in load is equipped with three conductor cable which plugs in an appropriate receptacle to ground the instrument's cover.

2.4 Adjust the feet

The 3300C Electronic load mainframe is equipped with feet and tilt stands installed and is ready for used as a bench instrument.

The feet provide a good viewing angle for bench-top use.



2.5 Rack mount

The 3300C mainframe is designed to permit mounted in a standard 19 inches rack for system application.

2.6 Environmental requirements

- 2.6.1 Indoor use.
- 2.6.2 Installation Category II .
- 2.6.3 Pollution Degree 2.
- 2.6.4 Altitude up to 2000 Meter.
- 2.6.5 Relative Humidity 80% Max.
- 2.6.6 Ambient Temperature 0 ~ 40
- 2.6.7 While the ideal operating temperature is 25 ± 5 degree centigrade.

2.7 Observe the International Electrical Symbol listed below

-  Warning ! Risk of electric shock.
-  Caution ! Refer to this manual before using the meter.

2.8 Cleaning and Storage

WARNING

TO avoid electrical shock or damage to the meter, do not get water inside the case.

Periodically wipe the case with a damp cloth and detergent; do not use abrasives or solvents.

2.9 Repairing

If the instrument is damaged, please attach a tag to the instrument to identify the owner and indicated the require service or repairing. And inform the Prodigit sales and service office or representative.

2.10 Accessories

The following parts should be include in the shipment.

- | | | |
|--------|------------------------------------|-----|
| 2.10.1 | Three conductor power cord | 1pc |
| 2.10.2 | GW3300C mainframe operation manual | 1pc |

2.11 GPIB connection

The GPIB connector on the rear panel connects the 3300C mainframe to the controller and to other GPIB devices. An GPIB system can be connected in any configuration (star, linear, or both) as long as

- 2.11.1 The maximum number of devices including the controller is no more than 15.
- 2.11.2 The maximum length of all cable in no more than 2 meters times the number of devices connected together, up to 20 meters maximum.

Please make sure the lock screws are firmly hand - tightened, use a screw-driver only for the removal of screws. Fig 2-3 shows the rear panel of 3300C mainframe, the GPIB connector is located on the rear panel of 3300C mainframe. The GPIB address of the 3300C mainframe is set on front panel.

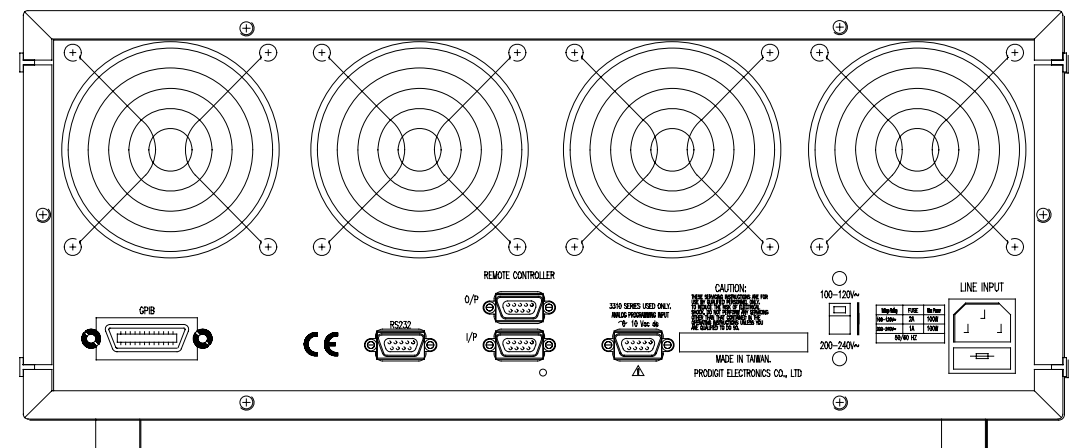

Fig 2-3 3300C REAR PANEL

2.12 RS-232C Connection

The RS-232C connector (Female) on the rear panel connects 3300C mainframe to RS-232C port of computer in one by one configuration.

2.13 Remote control Port

There are two D-sub 9 pin connector on the rear panel, the Remote Input port connects the 3300C mainframe to model 9931C remote controller and to replace the RECALL option key 1 to 5 on the front panel of 3300C mainframe, The LED will be lit if NG is occurred in any one of load module within 3300C mainframe.

The Remote output port can connect to another 3300C, 3300A or 3302 mainframe for cascade operation, this feature enable user to control up to 12 or more load module in a one memory recall operation, it is especially suitable for multiple output power supply testing applications.

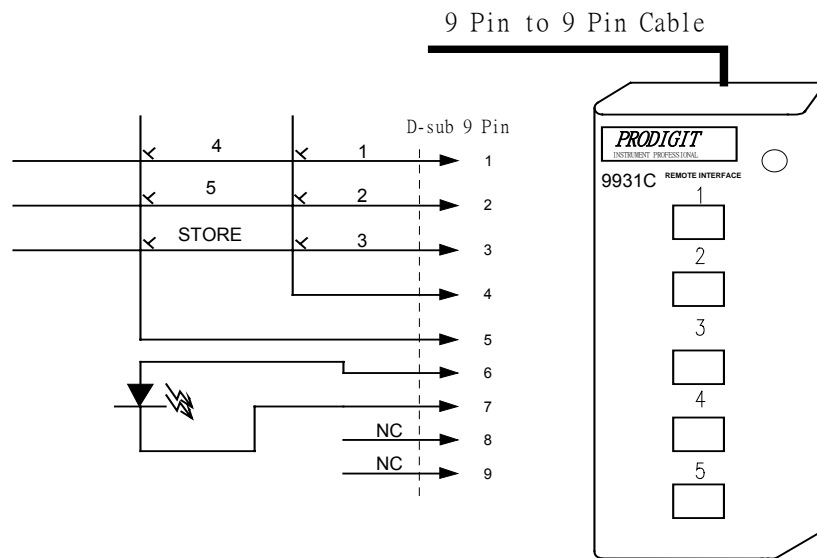

Fig 2-4 Diagram of Remote Control Port

2.14 Analog programming input

The D-sub 9 pin connector on the rear panel connects the 3300C mainframe to the 3310A/3310C series analog programming input or to the external sync input of 3250 series load module.

The pin definition is shown in fig 2-5.

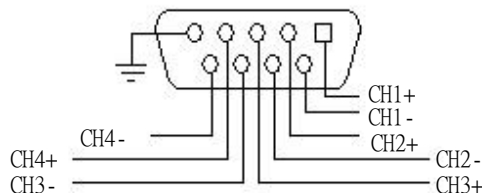

Fig 2-5 Diagram of analog programming input

Chapter 3 Mainframe operation

The front panel of 3300C mainframe is shown in Fig 3-1.

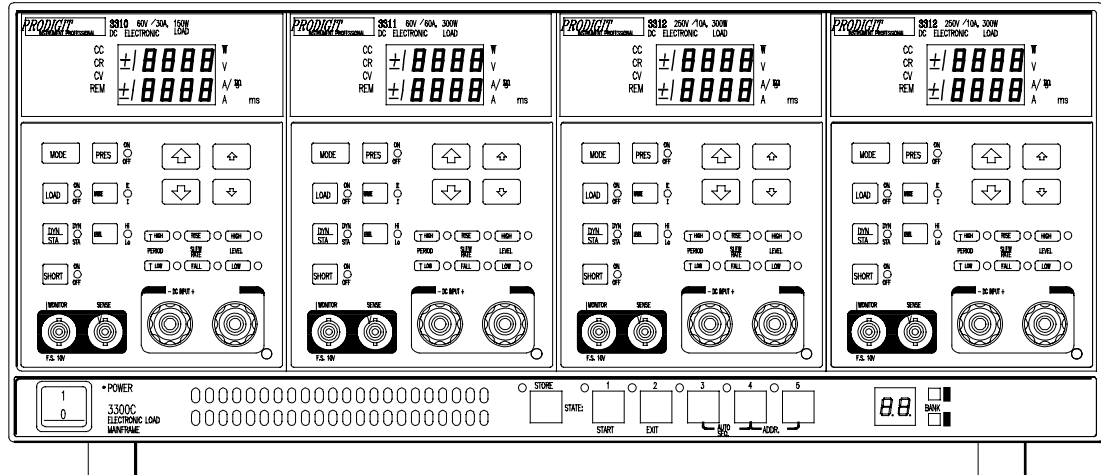

Fig 3-1 3300C FRONT PANEL

3.1 Feet stands

There are four feet which are located in each corner of the 3300C bottom plate. The two feet on the front panel side are equipped with stainless tilt stands, you can pull up the tilt stands to provide a good view angle of the 3250A/3310A/3310C/3330A series Electronic load module in the manual operation.

3.2 Power switch

Before connecting AC power to the 3300C mainframe, make sure the power source matches the power requirements of the 3300C Electronic load mainframe (as mark on the rear panel) Power switch turns 3300C mainframe and 3250A/3310A/3310C/3330A series Electronic load module ON or OFF, when the 3300C mainframe is first turn ON, the 3300C mainframe is indicated with the following configuration.

3.3 Power on status

3300C:

- 3.3.1 Local/manual operation mode.
- 3.3.2 STORE/RECALL : All LED is OFF, BANK LED display shows 01; 3300C series electronic load is in power on initial state.
- 3.3.3 3250A/3310A/3310C/3330A series electronic load is in power up initial state, please refer to electronic load module's operation manual.
- 3.3.4 GPIB address setting :
GPIB address is set by press STATE 4+STATE 5 simultaneously, press UP or DOWN key to select 0–31 address number, press STATE 2 to exit GPIB address setting mode.

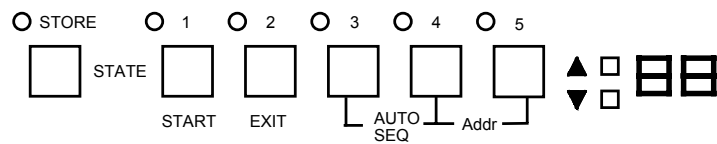

Fig 3-2 3300C front panel key switch

3.4 STORE / RECALL operation

The eight function keys on the front panel of 3300C mainframe are designed for high testing throughput purpose. There are 5 and 150 operation states or testing steps can be store in the EEROM memory of 3250A/3310A, and 3310C/3330A series electronic load module respectively, each state can save or recall the load status and level for four Electronic load modules simultaneously.

3.4.1 STORE procedure:

- 3.4.1.1 Set the load status and load level from load module within the mainframe respectively.
- 3.4.1.2 Skip this procedure for 3250A/3310A series load module, select the Memory Bank (01-30) to be store for 3310C and 3330A series load module.
- 3.4.1.3 Press the STORE key on the 3300C mainframe, the STORE LED annunciator is flashing (about two times every second) to indicate ready to store. Press Store key again or wait for about 20 sec to exit the store operation.

Press one of the state 1-5 key, the appropriate state key's LED annunciator will be lit immediately, the load level and status of 3310 series load module is stored into the EEROM memory this time. then the STORE LED annunciator turns to OFF, it means the STORE procedure is completed.

Note:

After press the STORE key, the STORE LED annunciator will flash for 20 seconds, if the STATE 1-5 key is not pressed within this 20 seconds, the STORE LED annunciator will be OFF, it indicated the STORE process is not available now, please repeat the STORE procedure for a new STORE operation.

After press the STORE key, then press the STORE key, the STORE LED annunciator will be blank, it indicate the STORE process is not available.

After press the STORE key, it is available and useful to operate the front panel key on the 3310 series Electronic load module. However, the STATE LED will be OFF if any key on any load module is operated, this indicates the front panel state of load module is not the same as STORE state.

3.4.2 STORE function:

Please refer chapter section on the 3250A/3310A/3310C/3330A series electronic load module operation manual to more detail operation flow-chart for store and recall operation.

It can store up to states of 3250A/3310A/3310C/3330A series load module setting

simultaneously, if you store 2 different states in the same state key, the later state will overcome the previous state, it acts as update the new data.

3.4.3 RECALL operation:

3.4.3.1 For 3250 and 3310A series, press one of the Memory State 1 through 5 key, the appropriate LED annunciator will be lit, the store state on the 3300C mainframe is sending to the electronic load module simultaneously. Before press the states key, you press any key on the load module then the state LED annunciator is blank immediately, it indicates the STORE state has been changed on load module's front panel.

3.4.3.2 For 3310C and 3330A series, using UP and Down key to select the Memory Bank, then follow the procedure (3.4.3.1) for the Memory Recall operation.

3.5 AUTO SEQUENCE testing function description

There are two modes in AUTO SEQUENCE function, EDIT MODE and TEST MODE, The AUTO SEQ mode can be entered by press S3 + S4 key simultaneously, then press STORE key again to enter the EDIT MODE, or press START key to enter the TEST MODE, Please refer to the flow chart operation below:

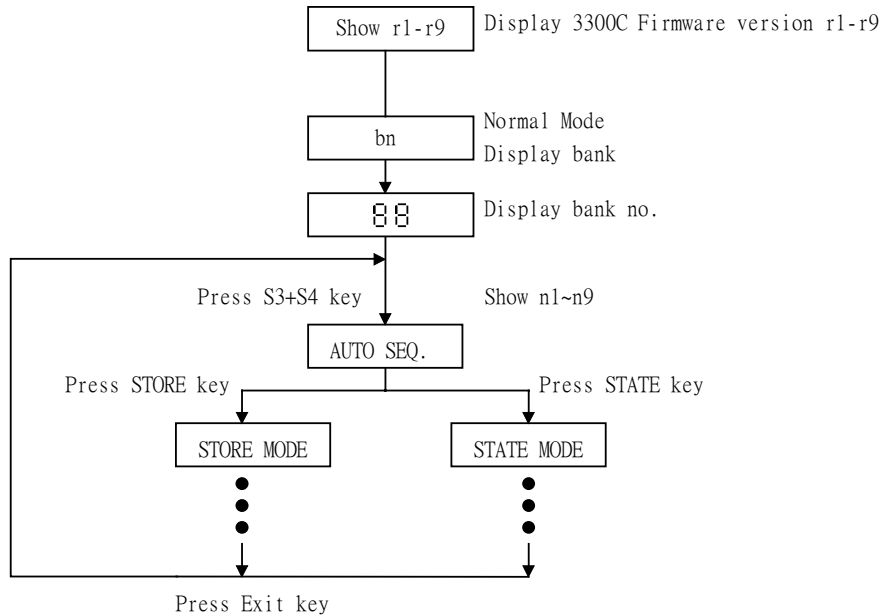

Fig 3-3 AUTO SEQ function operation flow chart

3.5.1 EDIT MODE

The TEST Mode of Auto-Sequence function is entered by press S3 + S4 key simultaneously, The EDIT mode of Auto Sequence function is entered by press S3 + S4 key simultaneously, the S3 and S4 LED are ON to indicate Auto-sequence mode, then the Edit mode of Auto-sequence function is proceed by press STORE key.

The EDIT MODE flow chart is described below:

- 3.5.1.1 There are nine Auto Sequence (n1-n9) can be edit within 3300C.
- 3.5.1.2 Each Auto Sequence has up to 16 Test step, where each step is any one memory of 150 sets Store memory which is 30 memory Bank with 5 memory state.
- 3.5.1.3 Each test step has t1 (test time) and t2 (delay time), the unit is 100mS, the range is 0.1S - 9.9S in 100mS resolution. 3300C mainframe will check each module GO/NG at the end of t1 (test time), the next step will be started after duration t2 (delay time).
- 3.5.1.4 The test step sequence can be up to 16 step, and can be terminated by press EXIT key if less than 16 step is required.

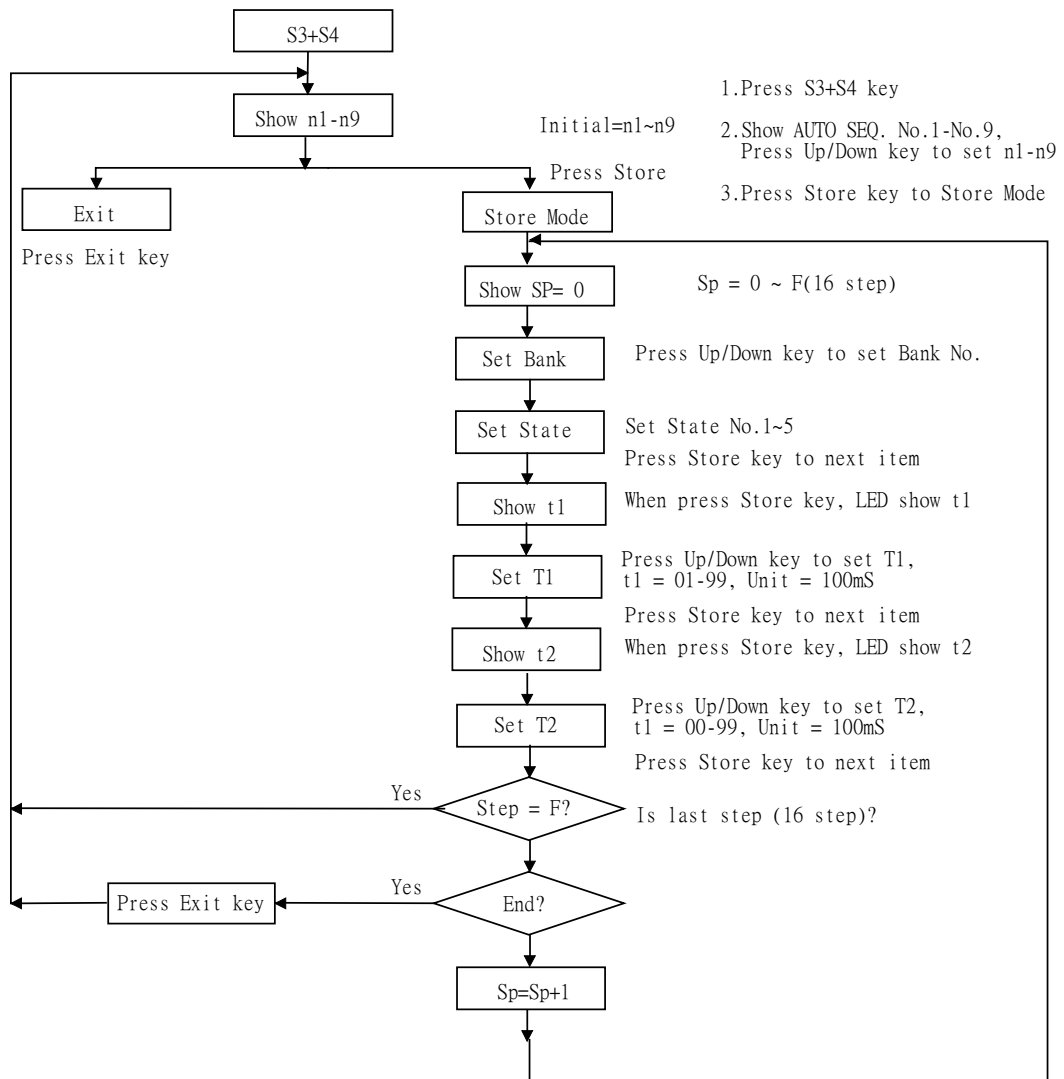

Fig 3-4 STORE (EDIT) MODE OPERATIONO FLOW-CHART

3.5.2 TEST MODE

The TEST Mode of Auto-Sequence function is entered by press S3 + S4 key simultaneously, the S3 and S4 LED are ON to indicate Auto-sequence mode, then the Test mode of Auto-sequence function is proceed by press START key.

The TEST MODE flow chart is described below:

- 3.5.2.1 After press START key, the 3300C controls all the module within the mainframe to recall correspond memory which had been stored in Auto-sequence (n1~n9) memory.
- 3.5.2.2 The sequence start from (Step 0 - t1 - t2), then (step 1 - t1 - t2), and so on until last step or stop by press EXIT key.
- 3.5.2.3 The two digit LED display will show GO (flash) if all the test in all module is pass, and will show nG (flash) if there is at least one failure during the test.
- 3.5.2.4 User can press Start key to continue another test, or the 3300C can quit from Auto-Sequence mode by press EXIT key.

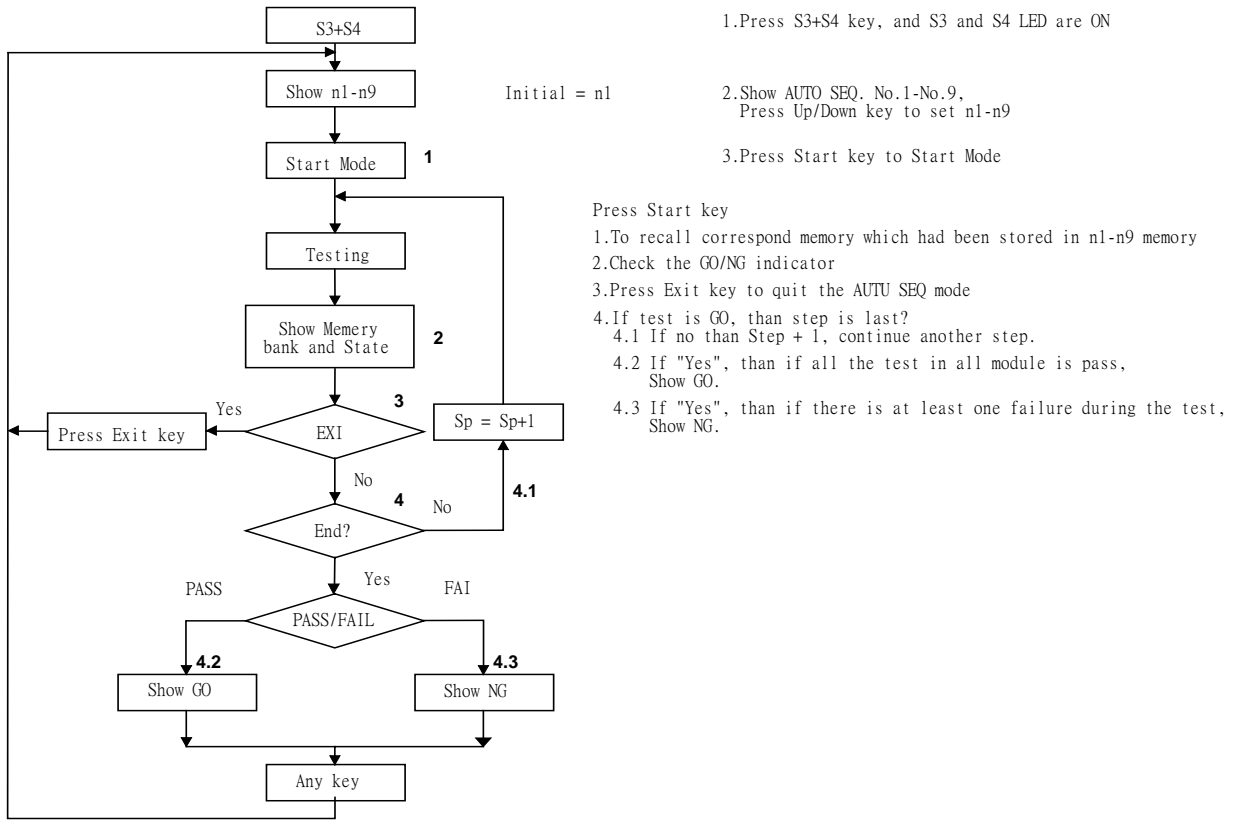

Fig 3-5 TEST MODE OPERATION FLOW-CHART

Chapter 4 GPIB/RS-232 programming operation

4.1 Introduction

The rear panel GPIB/RS-232 interface of 3300C mainframe is designed to connect PC (Personal Computer) or NOTEBOOK PC with GPIB/RS-232 interface, the NOTEBOOK PC acts as a remote controller of 3250/3310A/3310C/3330A series Electronic Load.

This feature can be used as an automatic load/cross load regulation and centering voltage testing for a switching power supply or an rechargeable battery charge/discharge characteristic testing. The function capability of rear panel GPIB/RS-232 interface not only can set the load level and load status, but also can read back the load voltage and load current.

4.2 The summary of GPIB command

The following GPIB setting commands are channel dependent command except "CHAN" command, so in the testing program, you should send channel specific command "CHAN" first, and then send channel dependent command for proper program execution.

For Example :

Short ON of channel 1 of 3310 series Electronic Load module, the GPIB programming command is : CHAN 1 : SHOR ON.

The following GPIB commands with [GLOB:] option can set all the 3310 series Electronic load module in 3300C mainframe to be active simultaneously; This feature can extremely reduce the testing program and become more efficiency.

4.3 The summary of RS-232 interface and command

The following RS-232 commands are same as GPIB commands. The RS-232 protocol in 3300C mainframe is listing below:

Baud-rate	: 9600
Parity	: none
Data bit	: 8 bits
Stop bit	: 1 bit
command delay time	: 20 mSec.

The connection of rear panel RS-232 interface is shown below, The Figure 4-1.a is connector wire diagram of rear panel RS-232 interface, User can use the general RS-232 cable as Figure 4-1.b.

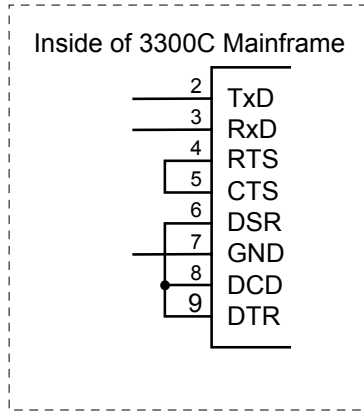

Figure 4-1.a

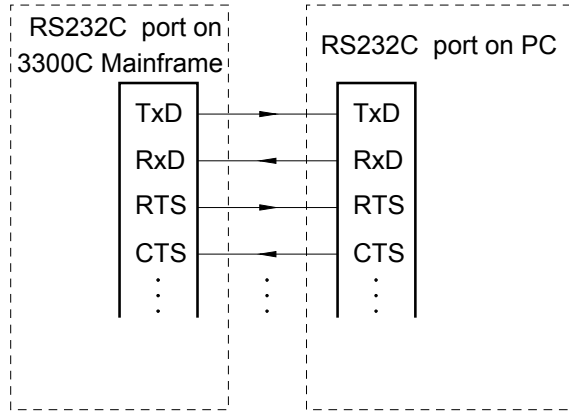

Figure 4-1.b

Fig 4-1 RS-232 INTERFACE DIAGRAM

The following RS-232 setting commands are channel dependent command except “CHAN” command, so in the testing program, you should send channel specific command “CHAN” first, and then send channel dependent command for proper program execution.

For example :

Short ON of channel 1 of 3310 series Electronic Load module, the RS-232 programming command is : CHAN 1 ; SHOR ON.

The following RS-232 commands with [GLOB:] option can set all the 3310 series Electronic load module in 3300C mainframe to be active simultaneously; This feature can extremely reduce the testing program and become more efficiency.

4.4 GPIB/RS-232C COMMAND LIST

3250A/3310A/3310C/3330A series GPIB/RS-232C setting and read back command are listed in table 4-1 and 4-2 .

SETTING PRESET NUMERIC COMMAND	MODEL				REMARK
	3310A	3310C	3330A	3250A	
[PRESET :] BANK{SP}{D}{ ; NL}				✓	D=0~10
[PRESET :] WAVE{SP}{M}{ ; NL}				✓	M=0~4
[PRESET :] FREQUENCY{SP}{NR2}{ ; NL}				✓	40.0~70.0HZ
[PRESET :] RISE{SP}{NR2}{ ; NL}	✓	✓			
[PRESET :] FALL{SP}{NR2}{ ; NL}	✓	✓			
[PRESET :] SLEWRATE{SP}{NR2}{ ; NL}			✓		
[PRESET :] PREIOD : {HIGH LOW}{SP}{NR2}{ ; NL}	✓	✓	✓		
[PRESET :] LDONV{SP}{NR2}{ ; NL}		✓	✓		
[PRESET :] LDOFFV{SP}{NR2}{ ; NL}		✓	✓		
[PRESET :] CC{SP}{NR2}{ ; NL}			✓		
[PRESET :] CC : {A B}{SP}{NR2}{ ; NL}				✓	
[PRESET :] CC : {HIGH LOW}{SP}{NR2}{ ; NL}	✓	✓	✓		
[PRESET :] CP : {HIGH LOW}{SP}{NR2}{ ; NL}		✓			
[PRESET :] CR{SP}{NR2}{ ; NL}			✓		
[PRESET :] CR : {A B}{SP}{NR2}{ ; NL}				✓	
[PRESET :] LIN : {A B}{SP}{NR2}{ ; NL}				✓	
[PRESET :] CR : {HIGH LOW}{SP}{NR2}{ ; NL}	✓	✓			
[PRESET :] CV : {HIGH LOW} {SP} {NR2}{ ; NL}	✓	✓			
[PRESET :] CV{SP}{NR2}{ ; NL}			✓		
[PRESET :] TCONFIG {SP} {NORMAL OCP OPP}{ ; NL}		✓			
[PRESET :] TCONFIG {SP} {NORMAL OCP OVP}{ ; NL}			✓		
[PRESET :] OCP:START {SP} {NR2}{ ; NL}		✓	✓		
[PRESET :] OCP:STEP {SP} {NR2}{ ; NL}		✓	✓		
[PRESET :] OCP:STOP {SP} {NR2}{ ; NL}		✓	✓		
[PRESET :] OCP:VTH {SP} {NR2}{ ; NL}		✓	✓		
[PRESET :] OPP:START {SP} {NR2}{ ; NL}		✓			
[PRESET :] OPP:STEP {SP} {NR2}{ ; NL}		✓			
[PRESET :] OPP:STOP {SP} {NR2}{ ; NL}		✓			
[PRESET :] OPP:VTH {SP} {NR2}{ ; NL}		✓			

TABLE 4-1 GPIB/RS-232 SETTING COMMAND SUMMARY

Note : 1.OCP/OPP and TCONFIG Function is available in 3310c REV : 3.06 or later
Function is available in 3311c REV : 3.06 or later
Function is available in 3312c REV : 3.09 or later
Function is available in 3314c REV : 3.07 or later
Function is available in 3315c REV : 3.06 or later
Function is available in 3300c REV : 3.4 or later

2.TCONFIG OPP Function is only have 3310c series.

QUERY PRESET NUMERIC COMMAND	MODEL				RETURN
	3310A	3310C	3330A	3250A	
[PRESET :] BANK{SP}{?}{ ; NL}				✓	0~10
[PRESET :] WAVE{SP}{?}{ ; NL}				✓	0~4
[PRESET :] FREQUENCY{?}{ ; NL}				✓	40.0~70.0
[PRESET :] RISE{?}{ ; NL}	✓	✓			###.####
[PRESET :] FALL{?}{NR2}{ ; NL}	✓	✓			###.####
[PRESET :] SLEWRATE{?}{ ; NL}			✓		###.####
[PRESET :] PREIOD : {HIGH LOW}{?}{ ; NL}	✓	✓	✓		###.####
[PRESET :] LDONV{?}{ ; NL}		✓	✓		###.####
(PRESET :] LDOFFV{?}{ ; NL}		✓	✓		###.####
(PRESET :] CC{?}{ ; NL}			✓		###.####
(PRESET :] CC : {A B}{?}{ ; NL}				✓	###.####
(PRESET :] CC : {HIGH LOW}{?}{ ; NL}	✓	✓	✓		###.####
(PRESET :] CP : {HIGH LOW}{?}{ ; NL}		✓			###.####
[PRESET :] CR{?}{ ; NL}			✓		###.####
[PRESET :] CR : {A B}{?}{ ; NL}				✓	###.####
[PRESET :] LIN : {A B}{?}{ ; NL}				✓	###.####
[PRESET :] CR : {HIGH LOW}{?}{ ; NL}	✓	✓	✓		###.####
[PRESET :] CV : {HIGH LOW}{?}{ ; NL}	✓	✓			###.####
[PRESET :] CV{?}{ ; NL}			✓		###.####
[PRESET :] TCONFIG {?}{; NL}		✓			1:NORMAL 2:OCP 3:3:OPP
[PRESET :] TCONFIG {?}{; NL}			✓		1:NORMAL 2:OCP 3:3:OVP
[PRESET :] OCP:START {?}{ ; NL}		✓	✓		###.####
[PRESET :] OCP:STEP {?}{; NL}		✓	✓		###.####
[PRESET :] OCP:STOP {?}{; NL}		✓	✓		###.####
[PRESET :] OCP:VTH {?}{; NL}		✓	✓		###.####
[PRESET :] OPP:START {?}{ ; NL}		✓			###.####
[PRESET :] OPP:STEP {?}{; NL}		✓			###.####
[PRESET :] OPP:STOP {?}{; NL}		✓			###.####

TABLE 4-2 GPIB/RS-232 QUERY COMMAND SUMMARY

LIMIT COMMAND	MODEL			RETURN
	3310C	3330A	3250A	
LIM : CURRENT : {HIGH LOW}{SP}{NR2}{ ; NL}	✓	✓	✓	
LIM : CURRENT : {HIGH LOW}{?}{ ; NL}	✓	✓	✓	###.####
LIM : POWER : {HIGH LOW}{SP}{NR2}{ ; NL}	✓		✓	
LIM : POWER : {HIGH LOW}{?}{ ; NL}	✓		✓	###.####
LIM : VA : {HIGH LOW}{SP}{NR2}{ ; NL}			✓	
LIM : VA : {HIGH LOW}{?}{ ; NL}			✓	###.####
LIM : VOLTAGE : {HIGH LOW}{SP}{NR2}{ ; NL}	✓	✓	✓	
LIM : VOLTAGE : {HIGH LOW}{?}{ ; NL}	✓	✓	✓	###.####

STAGE COMMAND	MODEL				RETURN
	3310A	3310C	3330A	3250A	
[STATE :] LOAD{SP}{ON OFF}{ ; NL}	✓	✓	✓	✓	
[STATE :] LOAD{?}{ ; NL}	✓	✓	✓	✓	0 : OFF, 1 : ON
[STATE :] MODE{SP}{CC CR CV CP}{ ; NL}	✓	✓	✓	✓	
[STATE :] MODE{?}{ ; NL}	✓	✓	✓	✓	0 : CC, 1 : CR 2 : CV, 3 : CP
[STATE :] SHORT{SP}{ON OFF}{ ; NL}	✓	✓	✓	✓	
[STATE :] SHORT{?}{ ; NL}	✓	✓	✓	✓	0 : OFF, 1 : ON
[STATE :] PRESET{SP}{ON OFF}{ ; NL}		✓	✓		
[STATE :] PRESE{?}{ ; NL}		✓	✓	✓	0 : OFF, 1 : ON
[STATE :] SENSE{SP}{ON OFF}{ ; NL}	✓	✓	✓	✓	
[STATE :] SENSE{?}{ ; NL}	✓	✓	✓		0 : OFF, 1 : ON
[STATE :] RANGE{SP}{I II}{ ; NL}	✓				
[STATE :] RANGE{?}{ ; NL}	✓				0 : I, 1 : II
[STATE :] LEVEL{SP}{HIG LOW AIB}{ ; NL}	✓	✓		✓	
[STATE :] LEVEL{?}{ ; NL}	✓	✓		✓	0 : LAOW, 1 : HIGH
[STATE :] DYNAMIC{SP}{ON OFF}{ ; NL}	✓	✓	✓		
[STATE :] DYNAMIC{?}{ ; NL}	✓	✓	✓		0 : OFF, 1 : ON
[STATE :] SYNCRONIZE{SP}{ON OFF}{ ; NL}				✓	
[STATE :] SYNCRONIZE{?}{ ; NL}				✓	0 : OFF, 1 : ON
[STATE :] WATT{SP}{ON OFF}{ ; NL}		✓		✓	
[STATE :] WATT{?}{ ; NL}		✓		✓	0 : OFF, 1 : ON
[STATE :] DUAL{SP}{DVM DAM OFF}{ ; NL}			✓		
[STATE :] PARALLEL{SP}{ON OFF}{ ; NL}			✓		
[STATE :] NGAB{SP}{ON OFF}{ ; NL}			✓		0 : OK, 1 : NG
[STATE :] NGAB{?}{ ; NL}			✓		0 : OK, 1 : NG
[STATE :] NG{?}{ ; NL}		✓	✓	✓	0 : OK, 1 : NG
[STATE :] PROTECT{?}{ ; NL}	✓	✓	✓	✓	DDDDDDDD
[STATE :] CC{SP}{AUTO R2} NOTE:		✓	✓		

Note: CC AUTO/Ran2 Function is available in 3300C REV : 3.3 or later
Function is available in 3310C REV : 3.05 or later
Function is available in 3311C REV : 3.05 or later
Function is available in 3312C REV : 3.06 or later
Function is available in 3314C REV : 3.05 or later
Function is available in 3315C REV : 3.05 or later
Function is available in 3330A REV : 3.17 or later
Function is available in 3331A REV : 3.17 or later
Function is available in 3332A REV : 3.17 or later
Function is available in 3333A REV : 3.17 or later
Function is available in 3334A REV : 3.17 or later

System command : Available for all modules

COMMAND	NOTE	RETURN
[SYSTEM :] CHANNEL{SP}{1 2 3 4}[A B]{ ; NL}		
[SYSTEM :] CHANNEL{SP}{?}{ ; NL}		{1 2 3 4}[A B]
[SYSTEM :] RECALL{SP}{M[,N]}{ ; NL}	M=1~5 N=1~30	
[SYSTEM :] STORE{SP}{M[,N]}{ ; NL}	M=1~5 N=1~30	
[SYSTEM :] REMOTE{ ; NL}	ONLY RS232 CMD	
[SYSTEM :] LOCAL{ ; NL}	ONLY RS232 CMD	0 : OFF, 1 : ON
[SYSTEM :] NAME{?}{ ; NL}		"XXXXX"

Measure command

COMMAND	3310A	3310C	3330A	3250	RETURN
MEASURE : CURRENT {?}{ ; NL}	✓	✓	✓	✓	###.####
MEASURE : VOLTAGE {?}{ ; NL}	✓	✓	✓	✓	###.####
MEASURE : PWR {?}{ ; NL}				✓	###.####
MEASURE : VA {?}{ ; NL}				✓	###.####

GLOBAL command

COMMAND	3310A	3310C	3330A	3250	RETURN
GLOBAL : [STATE :] PRESET{SP}{ON OFF}{ ; NL}	✓	✓	✓	✓	
GLOBAL : [STATE :] LOAD{SP}{ON OFF}{ ; NL}	✓	✓	✓	✓	
GLOBAL : [STATE :] MODE{SP}{ON OFF}{ ; NL}	✓	✓	✓	✓	
GLOBAL : [STATE :] SHORT{SP}{ON OFF}{ ; NL}	✓	✓	✓		
GLOBAL : [STATE :] DYNAMIC{SP}{ON OFF}{ ; NL}		✓	✓		
GLOBAL : [STATE :] LEVEL{SP}{HIGH LOW}{ ; NL}	✓	✓			
GLOBAL : [STATE :] LEVEL{SP}{A B}{ ; NL}				✓	
GLOBAL : [STATE :] RANGE{SP}{I II}{ ; NL}	✓	✓	✓		
GLOBAL : MEASURE : CURRENT{?}{ ; NL}	✓	✓	✓	✓	###.##
GLOBAL : MEASURE : VOLTAGE{?}{ ; NL}	✓	✓	✓	✓	###.##

REMARK :

1. d : 0 - 9
2. GLOB : GLOBAL (ALL CHANNELS ACTIVE IN SAME TIME)
3. CURRENT ENGINEERING UNIT : A
4. VOLTAGE ENGINEERING UNIT : V
5. RESISTANCE ENGINEERING UNIT : Ω
6. PERIOD ENGINEERING UNIT : mS
7. SLEW-RATE ENGINEERING UNIT : A/uS

Note : The RS-232 command set is same as GPIB command set.

※ 3310C Series and 3310A series GPIB command is compatible ,but the resolution is different ,
The different Description as following table .

機 型	CC MODE	CR MODE	CV MODE
3310C Resolution	0-3A/30A 0.8mA/8.0mA	0.1067 Ω -2 Ω -7.5k Ω 0.533m Ω /0.133mS	0V-60V 0.016V
3310A Resolution	0-3A/30A 0.75mA/7.5mA	0.1 Ω -2 Ω -8k Ω 0.5m Ω /0.125m Ω	0V-60V 0.015V
3311C Resolution	0-6A/60A 1.6mA/16mA	0.0533 Ω -1 Ω -3.75k Ω 0.266m Ω /0.266mS	0V-60V 0.016V
3311A Resolution	0-6A/60A 1.5mA/15mA	0.05 Ω -1 Ω -4k Ω 0.25m Ω /0.25m Ω	0V-60V 0.015V
3312C Resolution	0-1A/10A 0.266mA/2.66mA	1.333 Ω -25 Ω -18.75k Ω 6.666m Ω /0.053mS	0V-250V 0.0666V
3312A Resolution	0-1A/10A 0.25mA/2.5mA	1.25 Ω -25 Ω -20k Ω 0.05mS/6.25m Ω	0V-250V 0.0625V
3314C Resolution	0-0.5A/5A 0.133mA/1.33mA	5.333 Ω -100 Ω -18.75k Ω 26.66m Ω /13.333 μ S	0V-500V 0.133V
3314A Resolution	0-0.5A/5A 0.125mA/1.25mA	5 Ω -100 Ω -20k Ω 0.0125mS/25m Ω	0V-500V 0.125V
3315C Resolution	0-1.5A/15A 0.4mA/4.0mA	0.213 Ω -4 Ω -15k Ω 1.066m Ω /66.666 μ S	0V-60V 0.016V
3315A Resolution	0-1.5A/15A 0.375mA/3.75mA	0.2 Ω -4 Ω -16k Ω 1mS/0.0625m Ω	0V-60V 0.015V

TABLE 4-3 DIFFERENT DESCRIPTION

4.5 The description of abbreviation

SP : Space, the ASCII code is 20 Hexadecimal.

; : Semicolon, Program line terminator, the ASCII code is 0A Hexadecimal.

NL : New line, Program line terminator, the ASCII code is 0A Hexadecimal.

N : Integer number from 1 to 8.

NR2 : Digits with decimal point. It can be accepted in the range and format of ##.#####.

For Example :

30.12345, 5.0

The description of GPIB programming command syntax.

- { } : The contents of the { } symbol must be used as a part or data of the GPIB command, it can not be omitted.
- [] : The contents of the [] symbol indicates the command can be used or not. It depends on the testing application.
- | : This symbol means option. For example "A|B" means it can only use A or B as the command, it can choose only one as the setting command.
- Terminator : You have to send the program line terminator character after send the GPIB command, the available command terminator characters which can be accepted in 3300C mainframe is listed in Table 4-3.

LF
LF WITH EOI
CR, LF
CR, LF WITH EOI

TABLE 4-4 GPIB COMMAND TERMINATOR

A terminator informs GPIB that it has reached the end of statement. Normally, this is sent automatically by your GPIB programming statements. In this manual, the terminator is assumed at the end of each example line of code. If it needs to be indicated, it is shown by symbol (nl); which stand for "new line" and represents ASCII code byte the 0A Hexadecimal or 10 decimal.

- Semicolon ";" : The semicolon ";" is a back-up command, the semicolon allows you to combine command statement on one line to create command message.

4.6 GPIB/RS-232 command description

4.6.1 Setting Command

CHANNEL

Purpose :

“CHAN” selects the multiple Electronic load channel to which all subsequent channel specific command will be directed.

Command syntax :

CHAN{SP}n{;NL}

Description :

“CHAN” command selects the specified Electronic load module from 1 through 4 as the Electronic load module number. It can be installed up to 4 channels of the Electronic load module in one mainframe.

This command is a channel independent command, therefore, this command should be programmed before than Electronic Load channel dependent command.

The load channel number is arranged as 1, 2, 3, 4 from left hand side to the right hand side respectively.

For Example :

CHAN 2 select channel 2 of 3310 series Electronic Load.

Note :

Please refer to Appendix C for proper programming operation of 3310 series electronic load module.

CURRENT Level

Purpose :

The load current setting in Constant Current mode.

Command syntax :

CC : {LOW | HIGH}{SP}{NR2}{; | NL}

CC : {A | B}{SP}{NR2}{; | NL}

LIN : {A | B}{SP}{NR2}{; | NL}

CC{SP}{NR2}{; | NL}

Description :

CC : {LOW | HIGH}{SP}{NR2}{; | NL}

This command id used to set the current level of 3310 series Electronic Load module.

CC : {A | B}{SP}{NR2}{; | NL}

LIN : {A | B}{SP}{NR2}{; | NL}

This command is used to set the load current level A/B of 3250A series electronic load module.

CC : {SP}{NR2}{; | NL}

This command is used to set the load current level for CC static mode of 3330A series electronic load module.

Note:

- 1.The load current data must include decimal point, otherwise this command is unable to excute. The effective load current level can be programmed is the sixth digit after the decimal point.
- 2.The HIGH load level load current MUST be higher than LOW level load current for proper dynamic waveform definition, the load current difference between programmed

HIGH and LOW level is 10 times of resolution at each range, the 3310 series Electronic Load will adjust and limit of the programmed values.

If the programmed HIGH level is equal or less than LOW level, the 3310 series load module will adjust and limit HIGH level to be higher 10 times programming resolution of LOW level, and vice versa at the programmed LOW level is equal or more than HIGH level.

- 3.If the programming load current level over the maximum specification at programmed range of 3250A/3310 series load module, the full scale current will be sent to the load module.
- 4.Please make sure range I/II command before execute the load current setting command, otherwise the 3310 series load module will adjust to fit the load current after programming the RANGE command.
- 5.LOW|HIGH option is for 3310 series electronic load.
- 6.A|B option is for 3250A series electronic load.
- 7.Engineering unit for load current is Amps.
- 8.Please refer to Appendix C for proper programming procedure of 3310 series electronic load module.

For Example :

CC : LOW 1.8 set LOW level load current to 1.8 A.

CC : HIGH 25.123456 set HIGH level load current to 25.123456 A.

RESISTANCE Level

Purpose :

The load resistance setting in Constant Resistance mode.

Command syntax :

CR : {HIGH | LOW}{SP}{NR2}; | NL}

CR : {A | B}{SP}{NR2}; | NL}

CR : {SP}{NR2}; | NL}

Description:

CR : {HIGH | LOW}{SP}{NR2}; | NL}

This command is used to set the LOW/HIGH load resistance level of 3310 series electronic load module.

CR : {A | B}{SP}{NR2}; | NL}

This command is used to set the load resistance for LEVEL A/B of 3250 series electronic load module.

CR : {SP}{NR2}; | NL}

This command is used to set the load resistance level of 3330A Series load module.

Note :

- 1.The load resistance data must include decimal point, otherwise this command is unable to execute. The most effective load resistance level can be set is the sixth digit after the decimal point.
- 2.The HIGH load level load resistance MUST be higher than LOW level load resistance for proper HIGH/LOW resistance level definition, the load resistance difference between programmed HIGH and LOW level is 10 times of resolution at each range, the 3310 series Electronic Load will adjust and limit of the programmed values.

If the programmed HIGH level is equal or less than LOW level, the 3310 series load module will adjust and limit HIGH level to be higher 10 times programming resolution of

- LOW level, and vice versa at the programmed LOW level is equal or more than HIGH level.
- 3.If the programming load resistance level over the maximum specification at programmed range of 3310 series load module, the full scale resistance will be sent to the load module.
 - 4.Please make sure range I/II command before execute the load current setting command, otherwise the 3310 load current after programming the RANGE command.
 - 5.LOW|HIGH option is for 3310 series electronic load module.
 - 6.A|B option is for 3250 series electronic load module.
 - 7.The engineering unit for load resistance is Ohms.
 - 8.Please refer to Appendix C for proper programming procedure of 3310 series electronic load module.

For Example :

CR : LOW 0.123 set LOW level load resistance to 0.123 OHM.

CR : HIGH 3.456789 set HIGH level load resistance to 3.456789 OHM.

VOLTAGE Level**Purpose :**

The load voltage setting in Constant Voltage mode.

Command Syntax :

CV:{HIGH|LOW}{SP}{NR2}{;|NL}

CV:{SP}{NR2}{;|NL}

Description :

CV:{HIGH|LOW}{SP}{MISS}{;|NL}

This command is used to set the load voltage level of 3310A/3310C series Electronic load module.

CV {SP}{NR2}{;|NL}

This command is used to used to set the load Voltage level of 3330A series electronic load module.

Note:

- 1.The load voltage data must include decimal point, otherwise this command is unable to execute. The most effective load voltage level can be set is the sixth digit after the decimal point.
- 2.The HIGH load level load voltage MUST be higher than LOW level load voltage for proper HIGH/LOW voltage level definition, the load voltage difference between programmed HIGH and LOW level is 10 times of resolution, the 3310 series Electronic Load will adjust and limit of the programmed values.
If the programmed HIGH level is equal or less than LOW level, the 3310 series load module will adjust and limit HIGH level to be higher 10 times programming resolution of LOW level, and vice versa at the programmed LOW level is equal or more than HIGH level.
- 3.If the programming load voltage level over the maximum specification at programmed range of 3310 series load module, the full scale voltage will be sent to the load module.
- 4.The engineering unit for load voltage is Volts.
- 5.Please refer to Appendix C for proper programming procedure of 3310 series electronic module.

For Example :

CV:LOW 3.0 set LOW level load voltage to 3.0 V.

CV:HIG 45.123456 set HIGH level load voltage to 45.123456 V.

POWER Level**Purpose:**

The load power setting in Constant Power mode.

Command Syntax:

CP:{HIGH|LOW}{SP}{NR2}{;|NL}

Description:

This command is used to set the load Power level of 3310C series electronic load module.

Note : Mode CP is available in 3310C series only.

LOAD ON/OFF**Purpose :**

Turn the Electronic load module input ON or OFF.

Command syntax :

[GLOB :]LOAD{SP}{OFF|ON}{NL}

Description :

This command sets the Electronic load to sink current from power source. GLOB : LOAD ON All the Electronic load modules in the 3300C mainframe are ready to sink current from power source.

For example :

GLOB : LOAD OFF ; All the 3250/3310 series Electronic load modules in the 3300C mainframe are at input OFF condition.

CHAN : LOAD ON ; Set the channel 3 load module to LOAD ON status, this load module is ready to sink current from power source.

CHAN 1 : LOAD 0 ; Set the channel 1 load module LOAD OFF.

LOAD ON VOLTAGE Setting**Purpose:**

The Load ON voltage setting (Initial is 1.0V) of 3310C and 3330A series electronic load module.

Command Syntax:

LDON{SP}{NR2}{;|NL}

Description:

The Load On voltage can be adjusted by the LDON command, the adjust range is 0.1~25.0 V (Res. = 0.1V), the load on voltage setting for CH A and CH B is the same setting. The load will start to sink current if power source output voltage is higher than load on voltage.

LDON 2.5; Set the load on voltage is 2.5V, The load will start to sink current when power source output voltage is higher than 2.5V.

LOAD OFF VOLTAGE Setting**Purpose:**

The Load OFF voltage setting (Initial is 0.5V) of 3310C and 3330A series electronic load module.

Command Syntax:

LDOF{SP}{NR2}{;|NL}

Description:

The Load OFF voltage can be adjusted by the LDOF command, the adjust range is 0.1~ load on voltage (Res. = 0.1V), the load off voltage setting for CH A and CH B is the same setting. The load will stop to sink current if power source output voltage is lower than load off voltage.

LDOF 2.0 ; Set the load off voltage is 2.0V, The load will start to sink current when power source output voltage is lower than 2.0V.

LEVEL HIGH/LOW**Purpose :**

Select Low or High level in static mode, of 3310 series electronic load, or LEVEL A/B of 3250 series electronic load.

Command syntax : [GLOB :] LEVE {SP}{HIGH|LOW|A|B}{NL}

Description :

LEVE LOW is Set LOW current level in CC mode, LOW resistance level in CR mode, or LOW voltage level in CV mode at the active load channel.

LEVE 1 is Set HIGH current level in CC mode, HIGH resistance level in CR mode, or HIGH voltage level in CV mode at the active load channel.

LEVE B is The condition and setting of 3250 series electronic load adopt the set value of LEVEL B.

PRESET ON/OFF**Purpose :**

Set the upper or lower digit multi-function meter to display the programming load level.

Command syntax :

[GLOB :]PRES{SP}{0|1|OFF|ON}{NL}

Description :

GLOB : PRES ON is set all the load module in the 3300C mainframe to preset on status.

MODE**Purpose :**

Select the operating mode of Electronic load module.

Command syntax :

[GLOB :]MODE{SP}{0|1|2|3|CC|CR|CV|CP}{NL}

Description :

GLOB : MODE CC ; set the presently operating mode to Constant Current mode for all of the load module in the 3300C mainframe.

MODE CV ; set the presently operating mode to Constant Voltage mode.

MODE 1 ; set the presently operating mode to Constant Resistance mode.

MODE CP ; set the presently operation mode to Constant Power mode.

Note :

MODE CV is available in 3310A/3310C series only.

MODE CP is available in 3310C series only.

CLEAR status register

Purpose :

CLEAR the PROT and ERR status byte registers.

Command syntax :

CLER{NL}

Description :

CLER ; clear the PROT and ERR status byte register, the PROT and ERR status byte register will be indicated "0" after execute the CLER command.

STORE

Purpose :

STORE the load level and load status into the memory of the 3250, 3310 and 3330A series electronic LOAD.

Command syntax :

STOR{SP}{m[,n]};|NL}

Description :

Parameter m is 1~5 for 5 different states with 3250 and 3310A series electronic load module's load status and load current into the non-volatile memory in the 3250 and 3310A series electronic load.

Parameter n is 1~30 for 30 memory bank for 150 (m*n) different state with 3330A/3310C series electronic load module's load status and load current into the EEPROM memory in the 3330A and 3310C series electronic load.

For Example :

STORE 1; store the 3250, 3310A and 3320 series electronic load module's load status and load current into the memory 1.

STORE 2,30; store the 3330A and 3310C series electronic load module's load status and load current into the memory 147.

RECALL

Purpose :

Recall the state of load level and status which is stored by GPIB/RS232 STORE command.

Command syntax :

REC{SP}{m[,n]};|NL}

Description :

This command is used to recall the memory state which is store into the memory by GPIB/RS232 store command, up to 5 states can be recalled for 3250 and 3310A series electronic load module, up to 150 state can be recalled for 3330A and 3310C series electronic load module.

For Example :

REC 1; Recall the state of load level and status which is stored in memory 1 by GPIB/RS232 STOR command.

REC 147; Recall the state of load level and status which is stored in memory 147 by GPIB/RS232 STOR command.

SYNCHRONOUS ON/OFF

Purpose :

To set synchronous function ON/OFF of 3250 series electronic load module.

Command syntax :

SYNC{SP}{0|1|OFF|ON}{ ; |NL}

Description:

- 1.External synchronous signal (SYNC ON) : Using external synchronous signal as the synchronous triggering signal of the electronic load thus controlling the load current to be synchronous with the voltage.
- 2.Internal synchronous signal (SYNC OFF) : Using the signal at the terminal of the input connector thus generating synchronous signal through the internal zero-crossing circuit and isolated circuit.

For Example :

SYNC ON ; To set external synchronization.

SYNC OFF ; To set internal synchronization.

WATT Meter ON/OFF

Purpose :

To set display of power meter of 3250 series electronic load module.

Command syntax :

WATT{SP}{0|1|OFF|ON}{ ; |NL}

Description :

This command is to set the display of power meter. This command has to be used in conjunction with PRES : OFF. When setting to ON, the monitor on the top will change from voltmeter to Watt meter while the monitor at the bottom will change from ammeter to Volt-Ameter (VA) and the unit is "W" and "VA" respectively. When setting to OFF, the Watt meter on the top will change back to voltmeter while the VA meter at the bottom will change back to ammeter and the unit is "Vrms" and "Arms" respectively.

For Example :

PRES OFF

WATT ON ; to display WATT, VA meter.

WATT OFF ; to display Voltage, Current meter.

WAVEFORM BANK**Purpose :**

To set waveform bank for 3250A series electronic load module.

Command syntax :

BANK{SP}{d}{ ; |NL} d : 0~10

Description :

This command is to set the waveform bank desired to be selected.

1. waveform bank 0~2 are sine wave.
2. waveform bank 3~8 Set P.F.
3. waveform bank 3~8 are square wave.
4. waveform bank 10 is DC.
5. There are five (5) waveform information for each waveform bank, therefore, there is a total 55 waveform information for eleven (11) waveform banks. Waveform information is shown in Table 4-4.

For Example :

- a. BANK 1, to set waveform bank 1.
- b. BANK 10, to set waveform bank 10.

	WAVE FROM BANK	A	B	C	D	E
SINE WAVE	0	$\sqrt{2}$	2.0	2.5	3.0	3.5
	1	1.5	1.6	1.7	1.8	1.9
	2	3.0	3.1	3.2	3.3	3.4
C.F.= 2.0	3	P.F.= -0.85	P.F.= -0.80	P.F.= -0.75	P.F.= -0.70	P.F.= -0.65
C.F.= 2.5	4	P.F.= -0.70	P.F.= -0.65	P.F.= -0.60	P.F.= -0.50	P.F.= -0.40
C.F.= 3.5	5	P.F.= -0.50	P.F.= -0.45	P.F.= -0.40	P.F.= -0.35	P.F.= -0.30
C.F.= 2.0	6	P.F.= 0.85	P.F.= 0.80	P.F.= 0.75	P.F.= 0.70	P.F.= 0.65
C.F.= 2.5	7	P.F.= 0.70	P.F.= 0.65	P.F.= 0.60	P.F.= 0.50	P.F.= 0.40
C.F.= 3.5	8	P.F.= 0.50	P.F.= 0.45	P.F.= 0.40	P.F.= 0.35	P.F.= 0.30
SQUARE WAVE	9	1.0	1.1	1.2	1.3	1.4
DC	10	$\sqrt{2}$ dc	2dc	2.5dc	3.0dc	3.5dc

TABLE 4-5 WAVEFORM INFORMATION

WAVEFORM**Purpose :**

To set waveform for 3250A series electronic load module.

Command syntax :

WAVE{SP}{m}{ ; |NL} m : 0~4

Description :

This command is to set the current C.F. at CC MODE (Peak Value Factor).

This command works only at CC MODE. When BANK varies, these 5 sets of C.F. will at the same time define different C.F. as shown in Table 4-4. For details, please refer to 3250A Operation Manual.

For Example :

- a.WAVE 1 ; To set 2nd set C.F.
- b.WAVE 4 ; To set 5th set C.F.

FREQUENCY

Purpose :

Setting of Frequency Value for 3250A series electronic load module.

Command syntax :

FREQ{SP}{NR2}{ ; |NL}

Description :

This command is for setting the frequency value of electronic load. Upon directing command, attention has to be paid to the following items :

- 1.The frequency value designated must include the decimals, otherwise, the command will become null and void.
- 2.The minimum effective digit of the value is the fifth digit after the decimal point.
- 3.If the value designated exceeds the specification of said electronic load, the 3302 machine frame will send out the full scale current value of said electronic load specification.
- 4.The frequency range of 3250A series electronic load is 40.0~70.0Hz.
- 5.unit is Hz.

For Example :

- a.FREQ 50.0, to set frequency is 50.0Hz.
- b.FREQ 60.0, to set frequency is 60.0Hz.
- c.FREQ 0.1, to set frequency is 0.1Hz, that is to set DC.

VOLTAGE Limit

Purpose :

To set the upper/lower limit value of threshold voltage.

Command syntax :

LIM:VOLT:{HIGH|LOW}{SP}{NR2}{ ; |NL}

Description :

This command is to set the upper/lower limit value of threshold voltage. When input voltage is lower than the lower limit value or higher than the upper limit value, NG indicating light will come on to indicate "NO GOOD" .

For Example :

- LIM:VOLT:LOW 1.0 ; To set the lower limit value of threshold voltage is 1.0 V.
- LIM:VOLT:HIGH 200.0 ; To set the upper Limit vale of threshold voltage is 200.0V.

CURRENT Limit**Purpose :**

To set the upper/lower limit value of threshold current.

Command syntax :

LIM:CURR{HIGH/LOW}{SP}{NR2}{;|NL}

Description :

This command is to set the lower limit value of threshold current. When load sink current is lower than this lower limit value or higher than the upper limit value, NG indicating light will come on to indicate "NO GOOD" .

For Example :

LIM:CURR:LOW:0.05 ; To set the lower limit value of threshold current is 0.05A.

LIM:CURR:HIGH:10.0 ; To the upper limit value of threshold current is 10.0A.

POWER Limit**Purpose :**

To set the upper/lower limit value of threshold power (W).

Command syntax :

LIM:POW:{HIGH|LOW}{SP}{NR2}{;|NL}

Description :

This command is to set the upper/lower limit value of threshold power (WATT). When power (WATT) is lower than this lower limit value or higher than the upper limit value, NG indicating light will come on to indicate "NO GOOD" .

For Example :

LIM:POW:LOW 0.05 ; To set the lower limit value of threshold power (W) is 0.05 W.

LIM:POW:HIGH 250.0 ; To set the upper limit value of threshold power(W)is 250.0 W.

VA Limit**Purpose :**

To set the upper/lower limit value of threshold power (VA).

Command syntax :

LIM:VA:{HIGH|LOW}{SP}{NR2}{;|NL}

Description :

This command is to set the upper/lower limit value of threshold power (VA). When power (VA) is lower than this lower limit value or higher than the upper limit Value, NG indicating light will come on to indicate "NO GOOD" .

For Example :

LIM:VA:LOW 0.05 ; To set the lower limit value of threshold power (VA) is 0.05 VA.

LIM:VA:HIGH 250.0 ; To set the upper limit value of threshold power(VA)is 250.0 VA.

PERIOD**Purpose :**

Set the Tlow/Thigh duration of dynamic load in Constant Current mode.

Command Syntax :

PERI : {LOW|HIGH}{SP}{NR2}{NL}

Description :

The PERiod of dynamic waveform is composed by Tlow and Thigh. The PERIOD LOW and HIGH data must include decimal point, otherwise this command is unable to execute.

The effective PERIOD LOW and HIGH can be programmed is the sixth digit a after the decimal point. If the programming period of Tlow and Thigh setting over the maximum specification at programmed range of load module, the maximum duration of Tlow and Thigh will be sent to the load module.

Please make sure the appropriate timer range before execute the load the PERI LOW or HIGH command, otherwise the PERI load module will adjust to fit the Tlow and Thigh ranges after programming the PERD LOW or HIGH command. The engineering unit for PERI LOW and HIGH are "ms" .

Note:

1. There are four timer ranges in the Tlow / T high generator to produce a wide period dynamic range, these ranges are adjusted by 3310 series load module automatically which depends on the programmed Tlow / Thigh range.
2. For Example : The load CHA and CHIB USES the same T-high and T-low controller of 3330A series electronic load.

Example:

PERI : LOW 0.125;PERI : HIGH 0.8

The above GPIB command set LOW / HIGH load duration's are 0.125 ms and 0.8 ms respectively.

RISE Time**Purpose :**

RISE load current slew rate setting.

Command Syntax :

RISE{SP}{NR2}{NL}

Description :

The RISE load current slew rate of load level change or dynamic load can be programmed by RISE command. The RISE slew rate of 3310 series Electronic Load module can be fully independent to the FALL slew rate.

The RISE load current slew rate data must include decimal point, otherwise this command is unable to execute.

The effective RISE load current slew rate can be programmed is the sixth digit after the decimal point. If the programming load current level over the maximum specification at programmed range of 3310 series load module, the fastest RISE slew rate will be sent to the load module.

Please make sure range I/II command before execute the load RISE slew rate setting command, otherwise the 3310 series load module will adjust to fit the RISE slew rate after programming the RISE command. The engineering unit for RISE slew rate is "A/us" .

For Example :

RISE 1.25 set RISE slew rate to 1.25 A/us.

FALL Time**Purpose :**

FALL load current slew rate setting.

Command Syntax :

FALL{SP}{NR2}{NL}

Description :

The FALL load current slew rate of load level change or dynamic load can be programmed by FALL command. The FALL slew rate of 3310 series Electronic Load module can be fully independent to the RISE slew rate.

The FALL load current slew rate data must include decimal point, otherwise this command is unable to execute. The effective FALL load current slew rate can be programmed is the sixth digit after the decimal point. If the programming load current level over the maximum specification at programmed range of 3310 series load module, the fastest FALL slew rate will be sent to the load module.

Please make sure range I/II command before execute the load FALL slew rate setting command, otherwise the 3310 series load module will adjust to fit the FALL slew rate after programming the FALL command.

The engineering unit for FALL slew rate is "A/us" .

For Example :

FALL 0.124 set FALL slew rate to 0.124 A/us.

SLEW Rate**Purpose:**

Set the load current slew rate of 3330A series electronic load module.

Command Syntax:

SLEW{SP}{NR2}{; | NL}

Description:

Rise and Fall slew rate is the same from SLEW command setting of 3330A electronic load module.

The Slew rate has two range, and it follows the CC mode range change automatically, when CC Dynamic mode is in Range I, the slew rate is in range I, if CC Dynamic mode is in range II, then Slew rate is in range II.

SHORT ON/OFF**Purpose :**

Short the DC input of Electronic load module.

Command syntax :

[GLOB:]SHOR{SP}{0|1|OFF|ON}{NL}

Description :

This command applies the short across the input of the Electronic load. Executing SHOR does not effect any programmed settings and the Electronic load will return to them when the short is removed.

For Example :

GLOB : SHOR ON ; set all load module load input to short state.

CHAN 2;SHOR OFF ; set channel 1, 2 load module load input short open state.

SENSE ON/OFF

Purpose :

Set the voltage sense ON/OFF of Electronic load.

Command syntax :

[GLOB:]SENS{SP}{0|1|OFF|ON}{NL}

Description :

This command applies the short across the input of the Electronic load. Executing SHOR does not effect any programmed settings and the Electronic load will return to them when the short is removed.

For Example :

GLOB : SENS ON set all load module V-sense input to sense ON state.

CHAN 2;SENS OFF set channel 1, 2 load module V-sense input to sense OFF state.

DYNAMIC ON/OFF

Purpose :

Set DYNamic ON or OFF command.

Command syntax :

[GLOB :]DYN{SP}{0|1|OFF|ON}{NL}

Description :

GLOB : DYN OFF ; set all the load module in the 3300C mainframe to static load mode.

CHAN 4;DYN 1 ; set channel 4 load module to dynamic load mode.

NG Enable /Disable

Purpose :

Set Meter GO/NG check ON or OFF.

Command syntax :

NGAB{SP}{OFF|ON}{;|NL}

Description :

Setting NG ON or OFF indicates that the NG check is enable or disable, the NG ON or OFF can be changed by NGAB ON/OFF command. The Load GO/NG check includes voltage and current meter GO/NG check, so, user can set the current's Upper limit to max. and set the lower to min. if the current meter NG check is not required and vice versa.

Note : When CH A nG is set to oFF,the front panel NG A LED is disable.

Note : When CH B nG is set to oFF,the front panel NG B LED is disable.

PARAllel ON/OFF

Purpose :

A // b; Parallel Load Channel A and B for 3330A series electronic load.

Command Syntax :

PARA{SP}{ON|OFF}{;|NL}

Description:

The parallel ON/OFF command is available for Model 3330A, 3332A and 3334A. PARA command to set ON (Parallel) or OFF (Not Parallel). Dual Load parallel operation is available for same polarity load in a module, it can be two positive or two negative load.

During the parallel Loading operation, the load level and status of CH A and B is still independent, Only the current meter shows the CH A + CH B load current on Channel A's and B's current meter, user can use the DUAL command setting to display load current for CH A and B.

The 2 + or 2- load parallel operation, user should make a wire connection from each load channel input to power supply output.

RANGE I/II**Purpose :**

Select the operating full scale current range.

Command syntax :

[GLOB:]RANG{SP}{1|2|LOW|HIGH}{NL}

Description :

This command selects the full scale current range of the Electronic load. There are two full scale current range for each 3310 series Electronic load module. Table 4-5 shows the range I/II full scale current for each 3310 series load module.

	3310A	3311A	3312A	3314A	3315A
RANGE I	3.072	6.142	1.024	0.512	1.536
RANGE II	30.72	61.42	10.24	5.12	15.36

TABLE 4-6 RANGE I/II FULL SCALE CURRENT FOR 3310 SERIES LOAD

When RANG command is executed, the values of the current level are adjusted as follow:

- 1.If the existing current setting is within the new range, then the current level does not change.
- 2.If the existing current level is setting in not within the new range, then the current level is set to the maximum of new range. The maximum load current level is shows in Table 4-5.
- 3.Please refer to Appendix C for proper programming procedure of 3310 series electronic load module.

Note :

GLOB : RANG 1 ; set all load module to range I CHAN 1 ; RANG 2 set channel load module to range II.

DUAL**Purpose:**

Setting the Dual voltage or Dual current meter display of the 3330A series electronic load module.

Command Syntax:

DUAL{SP}{DVM|DAM|OFF}{;|NL}

Description :

The Dual V/A command is not in the control of CH A/B operation, it is an independent command operation, this command is used for dual voltage meter or current meter to be display on the two 5 digit LED display.

DUAL DVM; To set the meter is in dual voltage meter mode, the engineering unit is "V".

DUAL DAM; To set the meter is in dual current meter mode, the engineering unit is "A".

DUAL OFF; Disable the dual meter function, the upper 5 digit LED display is voltage meter, the lower 5 digit LED display is current meter.

AUTO | R2 (suitable for : 333XA/331XC series)**Command Syntax:**

CC {AUTO | R2}{ ; | NL}

Description:

To set up AUTO RANGE/RANGE II function

To set up AUTO RANGE auto change RANGE I/II

To explain:

To set up RANGE II not auto change RANGE I/II TO choose in RAGNE II

Note: CC AUTO/Ran2 Function is available in 3300C REV : 3.3 or later

Function is available in 3310C REV : 3.05 or later

Function is available in 3311C REV : 3.05 or later

Function is available in 3312C REV : 3.06 or later

Function is available in 3314C REV : 3.05 or later

Function is available in 3315C REV : 3.05 or later

Function is available in 3330A REV : 3.17 or later

Function is available in 3331A REV : 3.17 or later

Function is available in 3332A REV : 3.17 or later

Function is available in 3333A REV : 3.17 or later

Function is available in 3334A REV : 3.17 or later

OCP:START (suitable for 3330A/3310C series)**Command syntax:**

OCP:START {SP}{NR2}{;|NL}

Description:

The initial current of OCP testing.

OCP:STEP (suitable for 3330A/3310C series)**Command syntax:**

OCP:STEP {SP}{NR2}{;|NL}

Description:

The increment step current of each OCP test.

OCP:STOP (suitable for 3330A/3310C series)

Command syntax:

OCP:STOP {SP}{NR2}{;|NL}

Description:

The maximum current of OCP test.

OCP:VTH (suitable for 3330A/3310C series)

Command syntax:

OCP:VTH {SP}{NR2}{;|NL}

Description:

The threshold voltage when UUT output voltage is equal or lower than V-th during OCP test.

OPP:START (suitable for 3310C series)

Command syntax:

OPP:START {SP}{NR2}{;|NL}

Description:

The initial power of OPP testing.

OPP:STEP (suitable for 3310C series)

Command syntax:

OPP:STEP {SP}{NR2}{;|NL}

Description:

The increment step power of each OPP test.

OPP:STOP (suitable for 3310C series)

Command syntax:

OPP:STOP {SP}{NR2}{;|NL}

Description:

The maximum power of OPP test.

OPP:VTH (suitable for 3310C series)

Command syntax:

OPP:VTH {SP}{NR2}{;|NL}

Description:

The threshold voltage when UUT output voltage is equal or lower than V-th during OPP test.

TCONFIG NORMAL/OCP/OVP/OPP (suitable for 3310C/3330A series)

Command syntax:

TCONFIG {SP}{NORMAL/OCP/OVP/OPP}{;|NL}

Description:

1. There are 3 useful test modes can be set normal mode .OCP mode (over current protection) OVP mode.(over voltage protection) OPP mode (over power protection).
2. OPP mode is available in 3310c series only.
3. OVP mode is available in 3330A series only

Note : 1.OCP/OPP and TCONFIG Function is available in 3310c REV : 3.06 or later

Function is available in 3311c REV : 3.06 or later

Function is available in 3312c REV : 3.09 or later

Function is available in 3314c REV : 3.07 or later

Function is available in 3315c REV : 3.06 or later

Function is available in 3300c REV : 3.4 or later

4.6.2 Query Command

CHANNEL

Purpose :

The active channel query command.

Command syntax :

CHAN ? {NL}

Description :

CHAN ? return the active channel, "1~4" indicate the active channel is channel "1~4" .

CURRENT Level

Purpose :

The Constant Current mode's load current level query command.

Command syntax :

CC:{HIGH | LOW}{?}; | NL}

CC:{A | B}{?}; | NL}

CC{?}; | NL}

Description :

CURR:LOW? return the presently programmed low load current level in Constant Current mode of 3310 series electronic load module.

CURR? return the presently programmed load current level in Constant Current mode of 3330A series electronic load module.

CURR:A? return the LEVEL A load current setting of 3250 series electronic load. The returned data format is shown in Table 4-2, the engineering unit is "A" .

RESISTANCE Level

Purpose :

The Constant Resistance mode's load resistance level query command.

Command syntax :

CR:{HIGH | LOW}{?}; | NL}

CR:{A | B}{?}; | NL}

CR{?}; | NL}

Description :

RES:LOW? return the presently programmed low load resistance level in Constant Resistance mode of 3310 series electronic load module.

RES? return the presently programmed load resistance level in Constant Resistance mode of 3330A series electronic load module.

RES:B? return the LEVEL B load resistance setting of 3250 series electronic load.

The returned data format is shown in Table 4-2, the engineering unit is "OHM" .

VOLTAGE Level

The Constant Voltage mode's load voltage level query command.

Command syntax :

CV:{LOW|HIGH}?{NL}

Description :

CV:LOW? return the presently programmed low load voltage level in Constant Voltage mode of 3310 series electronic load module.

CV:HIG? return the presently programmed high load voltage level in Constant Voltage

mode of 3310 series electronic load module.

The returned data format is shown in Table 4-2, the engineering unit is "V".

POWER Level

The Constant Power mode's load power level query command.

Command syntax :

CP:{LOW|HIGH}?{NL}

Description :

CP:LOW? return the presently programmed low load power level in Constant Power mode of 3310 series electronic load module.

CP:HIG? return the presently programmed high load power level in Constant Power mode of 3310 series electronic load module.

The returned data format is shown in Table 4-2, the engineering unit is "W".

LOAD ON/OFF

Purpose :

LOAD ON or LOAD OFF status query command.

Command syntax :

LOAD?{NL}

Description :

LOAD? return the presently load status, "0" indicates LOAD OFF, and "1" indicates LOAD ON.

LOAD ON Voltage

Purpose :

LOAD ON voltage level query command.

Command syntax :

LDON?{;|NL}

Description :

LDON? return the presently programming load on voltage of 3330A series electronic load module.

LOAD OFF Voltage

Purpose :

LOAD OFF voltage level query command.

Command syntax :

LDOF?{;|NL}

Description :

LDOF? return the presently programming load off voltage of 3330A series electronic load module.

LEVEL HIGH/LOW

Purpose :

Static mode's LEVEL low or high status query command or active LEVEL of 3250 series electronic load query command.

Command syntax :

LEV?{NL}

Description :

LEV? return the presently level status, "0" indicates LEVEL LOW, and "1" indicates LEVEL HIGH.

PRESET ON/OFF

Purpose :

PRESet ON or OFF status query command.

Command syntax :

PRES?{NL}

Description :

PRES? return the presently preset status, "0" indicates PRESet OFF, and "1" indicates PRESet ON.

MODE

Purpose :

CC, CR, CV or CP operating mode query command.

Command syntax :

MODE?{NL}

Description :

MODE? return the presently operating mode status, "0" indicates CC MODE, "1" indicates CR MODE, and "2" indicates CV MODE, "3" indicates CP MODE.

CV MODE is available in 3310 series electronic load.

CP mode is available in 3310C series electronic load.

NAME

Purpose :

Electronic Load module model number query command.

Command syntax :

NAME?{NL}

Description :

NAME? return the activate Electronic Load channel's model number.

PROTECTION Status Register**Purpose :**

OPP, OTP, OVP, and OCP protection status query command.

Command syntax :

PROT?{NL}

Description :

PROT? return the presently protection status, the status byte register summarizes all of the protection status events from all status register. Table 4-6 describes the status byte the happened on the 3250/3310 series Electronic load. The PROT status byte register is cleared when a CLER command clear all of the PROT and ERR status registers.

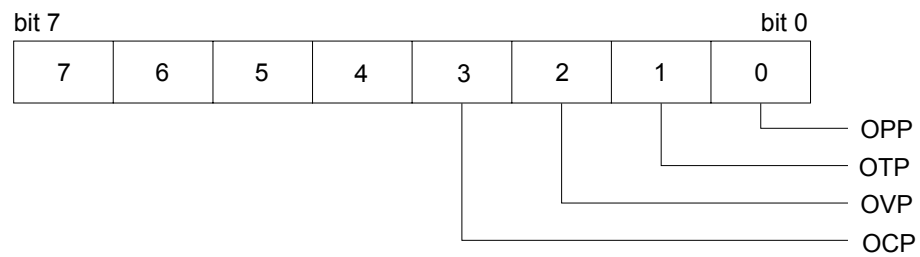

TABLE 4-7 PROT STATUS BYTE REGISTER

VOLTAGE METER

Purpose :

The reading of 4 1/2 digit voltage meter read back query command.

Command syntax :

MEAS : VOLT?{NL}

Description :

MEAS:VOLT? return the presently 4 1/2 digital voltage meter reading. The returned data format is shown in Table 4-2, the engineering unit is "V" .

CURRENT METER

Purpose :

The reading of 4 1/2 digit current meter read back query command.

Command syntax :

MEAS:CURR?{NL}

Description :

MEAS:CURR? return the presently 4 1/2 digital current meter reading. The returned data format is shown in Table 4-2, the engineering unit is "A" .

POWER METER

Purpose :

To read the value of Watt meter.

Command syntax :

MEAS : POW?{ ; |NL}

Description :

MEAS : POW? Read back the value of 4 digit of the Watt meter, unit is (W).

VA METER

Purpose :

To read the value of VAmeter.

Command syntax :

MEAS:VA?{ ; |NL}

Description :

MEAS : VA? Read back the value of 4 digit of VAmeter, unit is (VA).

GLOB : GLOBAL (ALL CHANNELS ACTIVE IN SAME TIME)

If the channel non-installed that will be read back 9999, to input buffer.

GLOB : MEAS : VOLT

Purpose :

The reading of 4 1/2 digit voltage meter from channel 1 to channel 4 read back query command.

Command syntax :

GLOB:MEAS:VOLT?{NL}

Description :

GLOB:MEAS:VOLT? return the presently 4 1/2 digital voltage meter reading from channel 1 to channel 4 respectively. The returned data format is shown in Table 4-2, the engineering unit is "V" .

For Example:

GLOB:MEAS:VOLT?

read back data is 4.998, 12.002, 9999., 11.998 where channel 1 voltage is 4.998V, channel 2 voltage is 12.002V, channel 3 is non-installed, channel 4 voltage is 11.998V.

GLOB : MEAS : CURR**Purpose :**

The reading of 4 1/2 digit current meter from channel 1 to channel 4 read back query command.

Command syntax :

GLOB:MEAS:CURR?{NL}

Description :

GLOB:MEAS:CURR? return the presently 4 1/2 digital current meter reading from channel 1 to channel 4 respectively, The returned data format is shown in Table 4-2, the engineering unit is "A" .

For Example:

GLOB:MEAS:CURR?

read back data is 4.998, 3.002, 9999., 0.998 where channel 1 current is 4.998 A, channel 2 current is 3.002 A, channel 3 is non installed, channel 4 current is 0.998 A.

SYNCHRONOUS ON/OFF

Purpose :

To read the setting condition of SYNC.

Command syntax :

SYNC?{ ; |NL}

Description :

SYNC? Read back the condition of SYNC. "0" denotes OFF, "1" denotes ON.

SENSE ON/OFF

Purpose :

To read the setting condition of Sense ON or OFF.

Command syntax :

SENS?{ ; |NL}

Description :

SENS? Read back the setting condition of SENS. "0" denotes OFF, "1" denotes ON.

WATT Meter ON/OFF

Purpose :

To read the setting condition of WATT.

Command syntax :

WATT?{ ; |NL}

Description :

WATT? Read back the setting condition of WATT. "0" denotes OFF, "1" denotes ON.

WAVEFORM BANK

Purpose :

To read the set value of BANK

Command syntax :

BANK?{ ; |NL}

Description :

BANK? Read back the set value of BANK. 0~10 denotes waveform bank of level 0~level 10.

WAVEFORM**Purpose :**

To read the set value of WAVE.

Command syntax :

WAVE?{ ; |NL}

Description :

WAVE? Read back the set value of WAVE. 0~4 denotes the C.F. setting of level 1~level 5.

FREQUENCY**Purpose :**

To read the set frequency of FREQ.

Command syntax :

FREQ?{ ; |NL}

Description :

Read back the set frequency of FREQ, unit is Hz.

VOLTAGE Limit**Purpose :**

To read the set value of upper/lower limit value of threshold voltage.

Command syntax:

LIM:VOLT:{HIGH/LOW}?{ ; |NL}

Description :

LIM:VOLT:LOW? Read back the lower limit set value of threshold voltage, unit is (V).

CURRENT Limit**Purpose :**

To read the set value of upper/lower limit value of threshold current.

Command syntax :

LIM:CURR{HIGH|LOW}?{ ; |NL}

Description :

LIM:CURR:LOW? Read back the lower limit set value of threshold current, unit is (A).

POWER Limit**Purpose :**

To read the set value of upper/lower limit value of threshold power(W).

Command syntax :

LIM:POW{HIGH|LOW}?{ ; |NL}

Description :

LIM:POW:LOW? Read back the lower limit set value of threshold power, unit is (W).

VA Limit**Purpose :**

To read the set value of upper/lower limit value of threshold power(VA).

Command syntax :

LIM:VA{HIGH|LOW}?{ ; |NL}

Description :

LIM:VA:LOW? Read back the lower limit set value of threshold power, unit is (VA).

NG**Purpose :**

To read the set value of NG.

Command syntax :

NG?{ ; |NL}

Description :

NG? Read back the condition indicating light of NG. "0" denotes that NG (NO GOOD) indicating light has been extinguished. "1" denotes that NG indicating light has been lit.

NG Enable /Disable**Purpose :**

To read NG ON/OFF setting.

Command syntax :

NGAB{?};|NL}

Description :

NGAB? return the presently NG ON/OFF status, "0" indicates NG disable, and "1" indicates NG enable.

PERIOD**Purpose :**

The dynamic mode's Tlow or Thigh duration query command

Command syntax :

PERI:{LOW|HIGH}?{NL}

Description :

PREI:LOW? return the presently programmed low duration time in dynamic load mode
PREI:HIGH? return the presently programmed high duration time in dynamic load mode
The returned data format is shown in Table 4-2, the engineering unit is "ms" .

RISE Time**Purpose :**

The dynamic load mode's RISE slew rate query command

Command syntax :

RISE?{NL}

Description :

RISE? return the presently programmed low load current level in Constant Current mode
The returned data format is shown in Table 4-2, the engineering unit is "A/us" .

FALL Time

Purpose :

The dynamic load mode's FALL slew rate query command.

Command syntax :

FALL?{NL}

Description :

FALL? return the presently programmed low load current level in Constant Current mode
The returned data format is shown in Table 4-2, the engineering unit is "A/us" .

SHORT ON/OFF

Purpose :

SHORT ON or OFF status query command.

Command syntax :

SHOR?{NL}

Description :

SHOR? return the presently SHORT status, "0" indicates SHORT OFF, and "1" indicates SHORT ON.

DYNAMIC ON/OFF

Purpose :

DYNAMIC ON or OFF status query command

Command syntax :

DYN?{NL}

Description :

DYN? return the presently DYNAMIC ON or OFF status, "0" indicates static load mode or DYNAMIC OFF, and "1" indicates DYNAMIC load mode or DYNAMIC ON.

RANGE I/II

Purpose :

RANGE I or RANGE II status query command.

Command syntax :

RANG?{NL}

Description :

RANG? return the presently range I or II status, "1" indicates RANGE I, and "2" indicates range II.

Appendix A GPIB programming Example

C Example Program

```

/* Link this program with appropriate *cib*.obj. */

/* This application program is written in TURBO C 2.0 for the IBM PC-AT compatible. The National
Instruments Cooperation (NIC) Model PC-2A board provides the interface between the PC-AT and
a PRODIGIT MPAL ELECTRONIC LOAD. The appropriate *cib*.obj file is required in each
program to properly link the NIC board to C LANGUAGE. and include the <decl.h.> HEADER FILE
to C LANGUAGE. */

#include <stdio.h>
#include <dos.h>
#include <math.h>
#include "decl.h"          /* NI GPIB CARD HEADER FILE */

main()
{
    char ouster[20],rdbuf[15],spec[10];
    int i,ch,load;
/* Assign unique identifier to the device "dev5" and store in variable load. check for error. ibfind
error = negative value returned. */
    if((load = ibfind("dev5")) < 0)    /* Device variable name is load */
        {                               /* GPIB address is 5 */
            printf("\r*** INTERFACE ERROR ! ***\a\n");
            printf("\r\nError routine to notify that ibfind failed.\n");
            printf("\r\nCheck software configuration.\n");
            exit(1);
        }
/* Clear the device */
    if((ibclr(load)) & ERR);
        {
            printf("INTERFACE ERROR ! \a");
            exit(1);
        }
    clrscr();
/* Clear load error register */
    for(i=1,ch=0;i<=4;i++,ch++)
        {
            outstr=chan[ch];
            ibwrt(load,outstr,6);
            ibwrt(load,"CLER",4);
        }
}

```

```
    ibwrt( load,"NAME?",5);          /* Get the 3310 series module load specification
*/
    strset(rdbuf,'\0');             /* Clear rdbuf string buffer */
    strset(spec,'\0');             /* Clear spec string buffer */
    ibrd(load,spec,20);
    if (spec[3] == '9')
        printf("\n 3300C series specification error!");
/* Set the channel 1, preset off, current sink 1.0 amps and load on commands to the load. */
    ibwrt( load,"chan 1;pres off;curr:low 0.0;curr high 1.0;load on ",51);
    ibwrt( load,"meas:curr ?",11);
/* Get the load actually sink current from the load */
    ibrd( load,rdbuf,20);
/* go to local. */
    ibloc(load);
}
```

BASICA Example Program

LOAD DECL.BAS using BASICA MERGE command.

```
100 REM You must merge this code with DECL.BAS
105 REM
110 REM Assign a unique identifier to the device "dev5" and store it in variable load%.
125 REM
130   udname$ = "dev5"
140   CALL ibfind (udname$,load%)
145 REM
150 REM Check for error on ibfind call
155 REM
160   IF load% < 0 THEN GOTO 2000
165 REM
170 REM Clear the device
175 REM
180   CALL ibclr (load%)
185 REM
190 REM Get the 3310 series module load specification
195 REM
200   wrt$ = "NAME?" : CALL ibwrt(load%,wrt$)
210   rd$ = space$(20) : CALL ibrd(load%,rd$)
215 REM
220 REM Set the channel 1, preset off, current sink 1.0 amps and load on commands to the load.
225 REM
230   wrt$ = "chan 1;pres off;curr:low 0.0;curr high 1.0;load on"
240   CALL ibwrt(load%,wrt$)
245 REM
250 REM Get the load actually sink current from the load
255 REM
260   wrt$ = "meas:curr?" : CALL ibwrt(load%,wrt$)
270   rd$ = space$(20) : CALL ibrd(load%,rd$)
275 REM
280 REM Go to local
285 REM
290 CALL ibloc(load%)

2000 REM Error routine to notify that ibfind failed.
2010 REM Check software configuration.
2020 PRINT "ibfind error !" : STOP
```

Appendix B RS-232 programming Example

C Language Interface for DOS Handlers " pd_rs232.c "

```

#include <dos.h>
#include <stdio.h>
#include <conio.h>
#include <string.h>

#define COMPTR          44          /* command array pointer          */
#define QUELEN          1024       /* size of serial input           */
#define SUCCESS         0          /* return value variable for success */
#define OPER_ERR        -1         /* operate error                  */
#define TIME_OUT        1          /*                               time_out */
/*
int input_index = 0;              /* index of serial input buffer    */
int rd_result = 0;                /* return value variable of pd_rd() */
int timeout = 0;                  /* timeout flag                    */
char queue[QUELEN];              /* serial input buffer             */
int ACE_DATA_REG;                /* ACIA data register             */
int ACE_INT_ENB_REG;             /* ACIA interrupt enable register */
int ACE_INT_IDENT_REG;          /* ACIA interrupt identification register*/
int ACE_LINE_CTL_REG;           /* ACIA line control register     */
int ACE_MODEM_CTL_REG;          /* ACIA modem control register   */
/*
int ACE_LINE_STAT_REG;           /* ACIA line status register      */
int ACE_MODEM_STAT_REG;          /* ACIA modem status register     */
int COM_INT_NUM;                /* ACIA communication port interrupt number*/
int IRQ_MASK;                   /* IRQ mask for PC IRQ flag       */
void pd_loc(void);               /* function of disable interrupt routine */
void pd_rem(void);               /* function of enable interrupt routine */
int pd_init(int);                /* function of initial communication port*/
int pd_wrt(char *,int);          /* function of write to device     */
int pd_rd(char *,int);           /* function of read from device    */
int read_buf(void);
int pd_meas(char *,char*, int, int);

#define PIC_CTL_REG          0x20   /* 8259A PIC control register     */
#define PIC_INT_MASK_REG     0x21   /* 8259A PIC interrupt mask register */
#define NON_SPEC_EOI         0x20   /* non-specific end of interrupt  */

```



```
#define CTS          0x10      /* clear to send          */
#define DSR          0x20      /* data set ready         */
#define RI           0x40      /* ring indicator         */
#define DCD          0x80      /* data carrier detect    */
#define DCTS         1        /* delta clear to send    */
#define DDSR         2        /* delta data set ready   */
#define TERI         4        /* trailing edge ring detect */
#define DDCD         8        /* delta data carrier detect */
#define OE           2        /* overrun error          */
#define PE           4        /* parity error           */
#define FE           8        /* frame error            */
#define BI           0x10     /* break interrupt        */
#define THRE         0x20     /* transmit holding reg. empty */

/* 3300C series elec. load command sets */
int pd_wrt(char *wrtbuf,int count)
{
    static char *combuf[COMPTR] = {"CHAN",      "CURR:HIGH", "CURR:LOW",
                                   "RES:HIGH", "RES:LOW", "VOLT:HIGH",
                                   "VOLT:LOW", "PERD:HIGH", "PERD:LOW",
                                   "FALL",      "RISE",      "GLOB:LOAD",
                                   "GLOB:LEV", "GLOB:PRES", "GLOB:SHOR",
                                   "GLOB:DYN", "GLOB:RANG", "GLOB:MODE",
                                   "CLER",      "CHAN?",      "MEAS:VOLT?",
                                   "MEAS:CURR?","CURR:HIGH?","CURR:LOW?",
                                   "ERR?",      "RES:HIGH?", "RES:LOW?",
                                   "VOLT:HIGH?","VOLT:LOW?", "NAME?",
                                   "PERD:HIGH?","PERD:LOW?", "FALL?",
                                   "RISE?",      "LOAD?",      "LEV?",
                                   "PRES?",      "SHOR?",      "DYN?",
                                   "RANG?",      "MODE?",      "PROT?",
                                   "REMOTE",     "LOCAL" };

    int cnt,result,t;
    int comerr,err;
    char ch;
    char tempbuf[QUELEN];
    char intbuf[QUELEN];
    /* for (cnt = 0;cnt < 1024;cnt++)
       {
           intbuf[cnt] = "";
           tempbuf[cnt]="";
       }
    */
}
```

```
} */
strset(intbuf,"");
strset(tempbuf,"");
for (cnt = 0;cnt < count+1;cnt++,wrtbuf++)
{
    intbuf[cnt] = *wrtbuf;
}
cnt = cnt--;
intbuf[cnt] = '\r';
cnt = cnt++;
count = count++;
intbuf[cnt] = '\n';
t = strcspn(intbuf," ");
if (t >count)
t = count-1;
for (cnt = 0;cnt < t;cnt++)
{
    tempbuf[cnt] = intbuf[cnt];
}
strupr(tempbuf);
strupr(intbuf);
cnt = 0;
do
{
    comerr = strncmp(tempbuf,combuf[cnt],t);
    cnt = cnt++;
}while(( cnt != COMPTR) && (comerr != 0));
if ( comerr == 0)
{
    result = SUCCESS;
    for (cnt = 0;cnt < count+1;cnt++)
    { while(inportb(ACE_LINE_STAT_REG) & THRE == 0);
      ch = intbuf[cnt];
      delay(20);
      outportb(ACE_DATA_REG, ch);
    }
    timeout = 0;
    for (cnt = 0; cnt <= count;cnt++)
    {
        ch = intbuf[cnt];
```

```
        if(ch == '?')
        {
            do
            {
                read_buf();
            }while((rd_result == 0)&&(timeout == 0));
            rd_result = 0;
        }
    }
    for (cnt = 0;cnt<= count;cnt++)
    {
        intbuf[cnt] = "";
        tempbuf[cnt] = "";
    }
    return(result);
}
return(OPER_ERR);
}
int pd_rd(char *buf,int count)
{
    char ch;
    int cnt = 0;
    do
    {
        ch = queue[cnt];
        *buf = ch;
        cnt = cnt++;
        buf = buf++;
    }while((ch != '\n') && (cnt != count));
    *buf = '\0';
    queue[0] = '\0';
    if (timeout == 1)
    {
        return(TIME_OUT);
    }
    return(SUCCESS);
}
int read_buf()
```

```

{
char ch,ch1;
int temp_index;
unsigned long ticks;
float sec1,sec2;
rd_result = 0;
ticks = biostime(0,0);
sec1 = ticks/18.2;
do
{
    ticks = biostime(0,0);
    sec2 = ticks/18.2;
    if((sec2 - sec1) >= 20.0)                /* delay about 1 Sec */
    {
        timeout = 1;
    }
    ch = inportb(ACE_INT_IDENT_REG);
    ch &= 0x06;
    switch(ch)
    {
        case 6:
            inportb(ACE_DATA_REG);          /* read the data register to empty it */
            break;
        case 0:
            break;
        case 2:
            break;
        case 4:
            /* read character from data register */
            ch1 = inportb(ACE_DATA_REG);
            temp_index = input_index + 1;    /* increment index of input buffer*/
            if (ch1 != '\n')                /* check terminate bit */
            {
                queue[input_index] = ch1;   /* store character to input buffer*/
                input_index = temp_index;
            }
            else
            {
                queue[input_index] = ch1;
                input_index = temp_index;
                input_index = 0;             /* if terminate bit was detected */
                temp_index = 0;
                rd_result = 1;              /* clear index and set return value */
            }
            break;
    }
}
/* finally send the non-specific */

```

```

    }while ((rd_result == 0) && (timeout == 0));
}

int pd_init(int pd_com)
{
    if ((pd_com != 1) && (pd_com != 2))
        return(OPER_ERR);
    if (pd_com == 2)
        /* initial communication port 2 */
        {
            ACE_DATA_REG      = 0x2f8;
            ACE_INT_ENB_REG   = 0x2f9;
            ACE_INT_IDENT_REG = 0x2fa;
            ACE_LINE_CTL_REG  = 0x2fb;
            ACE_MODEM_CTL_REG = 0x2fc;
            ACE_LINE_STAT_REG = 0x2fd;
            ACE_MODEM_STAT_REG = 0x2fe;
            COM_INT_NUM       = 11;
            IRQ_MASK          = 0xf7;
            /* IRQ mask for IRQ3 (11110111)
        */
        }
    else
        /* initial communication port 1 */
        {
            ACE_DATA_REG      = 0x3f8;
            ACE_INT_ENB_REG   = 0x3f9;
            ACE_INT_IDENT_REG = 0x3fa;
            ACE_LINE_CTL_REG  = 0x3fb;
            ACE_MODEM_CTL_REG = 0x3fc;
            ACE_LINE_STAT_REG = 0x3fd;
            ACE_MODEM_STAT_REG = 0x3fe;
            COM_INT_NUM       = 12;
            IRQ_MASK          = 0xef;
            /* IRQ mask for IRQ4 (11101111)
        */
        }
    bioscom(0, 0xe3, pd_com-1);
    pd_rem();
    pd_wrt("remote",6);
    return(SUCCESS);
}

int pd_meas(char *wrtmbuf, char *rdmbuf,int wrtmcnt,int rdmcnt)
{
    static char *wrtbuf[10] = { "CURR 1", "CURR 2", "CURR 3", "CURR 4",
                                "VOLT 1", "VOLT 2", "VOLT 3", "VOLT 4", }

```

```
char tmpbuf[20]={"chan "};
int cnt,result,t,cmp,measerr;
char ch;
char rdtmpbuf[20],chanbuf[20];
char measbuf[6];
for (cnt = 0; cnt < wrtmcnt; cnt++, wrtmbuf++)
{
    measbuf[cnt] = *wrtmbuf;
}
strupr(measbuf);
cnt = 0;
do
{
    measerr = strncmp(measbuf,wrtbuf[cnt],6);
    cnt = cnt++;
}while((cnt != 10) && (measerr != 0));
if(measerr == 0)
{
    result = SUCCESS;
    if (strncmp(measbuf,"CURR", 4) == 0)
    {
        ch = measbuf[5];
        switch(ch)
        {
            case '1':
                pd_wrt("chan 1",6);
                pd_wrt("meas:curr?",10);
                pd_rd(rdmbuf,rdmcnt);
                strncat(tmpbuf,chanbuf,1);
                pd_wrt(tmpbuf,6);
                break;
            case '2':
                pd_wrt("chan 2",6);
                pd_wrt("meas:curr?",10);
                pd_rd(rdmbuf,rdmcnt);
                strncat(tmpbuf,chanbuf,1);
                pd_wrt(tmpbuf,6);
                break;
            case '3':
                pd_wrt("chan 3",6);
                pd_wrt("meas:curr?",10);
                pd_rd(rdmbuf,rdmcnt);
                strncat(tmpbuf,chanbuf,1);
                pd_wrt(tmpbuf,6);
```

```
        break;
    case '4':
        pd_wrt("chan 4",6);
        pd_wrt("meas:curr?",10);
        pd_rd(rdmbuf,rdmcnt);
        strncat(tmpbuf,chanbuf,1);
        pd_wrt(tmpbuf,6);
        break;
    }
}
else if(strncmp(measbuf,"VOLT",4) == 0)
{
    ch = measbuf[5];
    switch(ch)
    {
    case '1':
        pd_wrt("chan 1",6);
        pd_wrt("meas:volt?",10);
        pd_rd(rdmbuf,rdmcnt);
        strncat(tmpbuf,chanbuf,1);
        pd_wrt(tmpbuf,6);
        break;
    case '2':
        pd_wrt("chan 2",6);
        pd_wrt("meas:volt?",10);
        pd_rd(rdmbuf,rdmcnt);
        strncat(tmpbuf,chanbuf,1);
        pd_wrt(tmpbuf,6);
        break;
    case '3':
        pd_wrt("chan 3",6);
        pd_wrt("meas:volt?",10);
        pd_rd(rdmbuf,rdmcnt);
        strncat(tmpbuf,chanbuf,1);
        pd_wrt(tmpbuf,6);
        break;
    case '4':
        pd_wrt("chan 4",6);
        pd_wrt("meas:volt?",10);
        pd_rd(rdmbuf,rdmcnt);
        strncat(tmpbuf,chanbuf,1);
        pd_wrt(tmpbuf,6);
    }
```

```

        break;
    }
}
else
{
    return(OPER_ERR);
}
return (result);
}

void pd_rem(void)
{
    char ch;
    outportb(ACE_INT_ENB_REG, 0xd);          /* enable ACIA interrupt register */
    inportb(ACE_DATA_REG);                   /* empty receive data register */
    inportb(ACE_LINE_STAT_REG);             /* clear line status register */
    /*
    outportb(ACE_MODEM_CTL_REG, 0xb);        /* set RTS,DTR to enable
modem and */

    /* turn on OUT2 to enable the 8250's */
    /* IRQ interrupt to system */

}
void pd_loc(void)
{
    char ch;
    outportb(ACE_INT_ENB_REG, 0);           /* disable all 8250 interrupt */
    outportb(ACE_MODEM_CTL_REG, 0);        /* clear RTS,DTR to disable modem and */
    /* turn off OUT2 to disable the 8250's*/
    /* IRQ interrupt to system */

}/* Program terminated. */

```

C Example Program

```
/* Link this program with pd_rs232.obj */
```

```

#include <dos.h>
#include <stdio.h>
#include <conio.h>
#include <string.h>

```

```
main()
```



```
{
    int com;
    int io_err= 0;
    char rdbuf[1024];
    clrscr();
    printf("Input COM1/COM2 port is : ");
    scanf("%d", &com);
    if((io_err = pd_init(com)) == 0)          /* Initial RS-232 interface */
    {
        setstr(rdbuf,"");
        pd_wrt("chan 1",6);
        delay(200);
        pd_wrt("name?",5);
        if ((io_err = pd_rd(a,10)) == 0)
        {
            do
            {
                /* Set the channel 1, preset off, current sink 1.0 amps and load on commands to the load. */
                pd_wrt("chan 1",6);
                delay(200);
                pd_wrt("pres off",8);
                delay(200);
                pd_wrt("curr:low 0.0",12);
                delay(200);
                pd_wrt("curr high 1.0",13);
                delay(200);
                pd_wrt("load on",7);
                delay(200);
                pd_wrt("meas:curr ?",11);
                /* Get the load actually sink current from the load */
                delay(200);
                pd_rd(rdbuf,20);
                io_err = 1;
            }while (io_err == 0);
        }
        else
        {
            printf("\a");
            printf("chan 1 I/O reading error !\n");
            exit(1);
        }
        pd_loc(); /* Go to local */
    }
}
```

Appendix C 3250A Series GPIB/RS-232 Operating flow chart

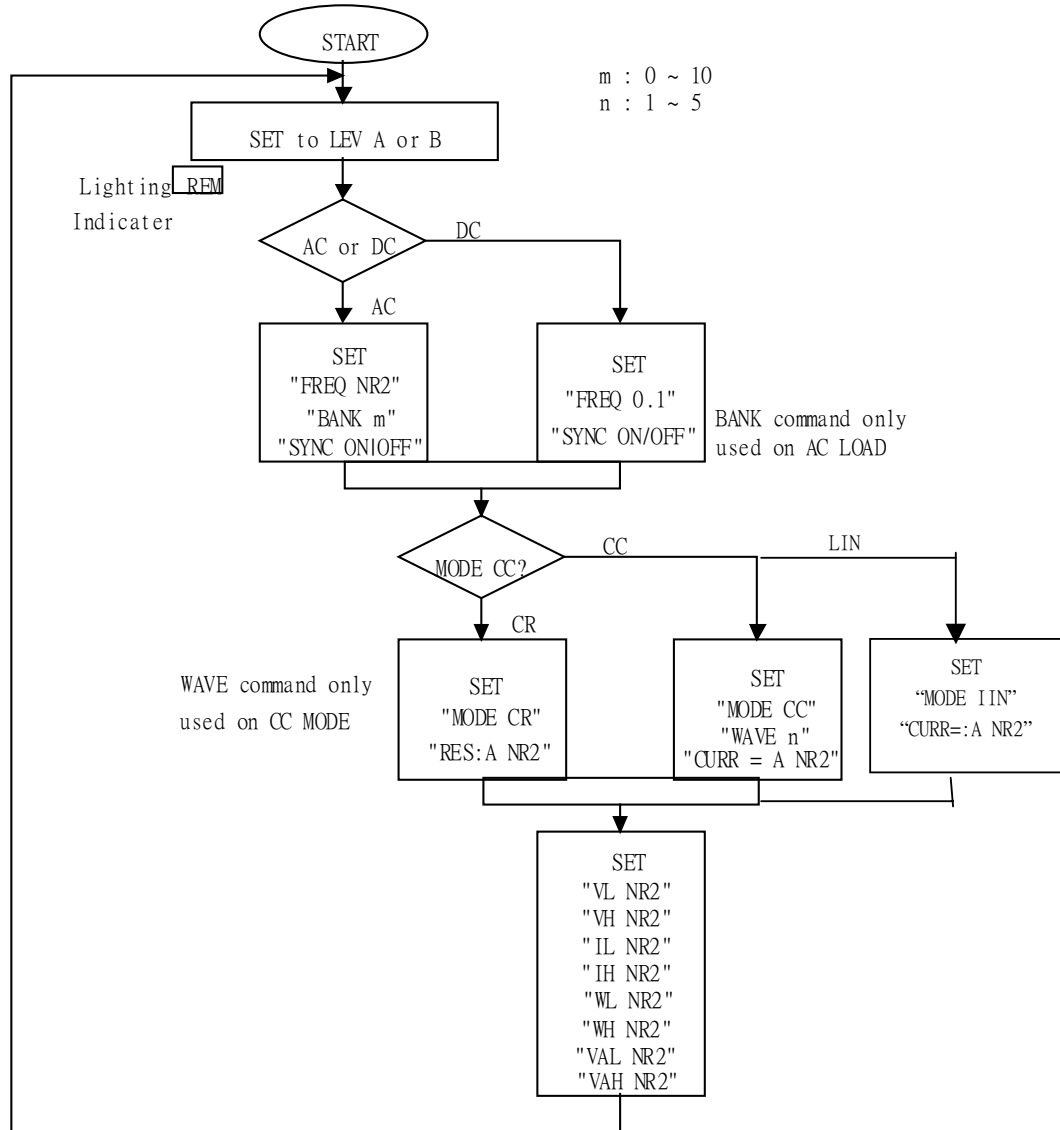

Appendix D 3310A Series GPIB/RS-232 Operating flow chart

The following flow chart shows the typical 3300C Series mainframe remote control and load current level and status setting procedures of each load module.

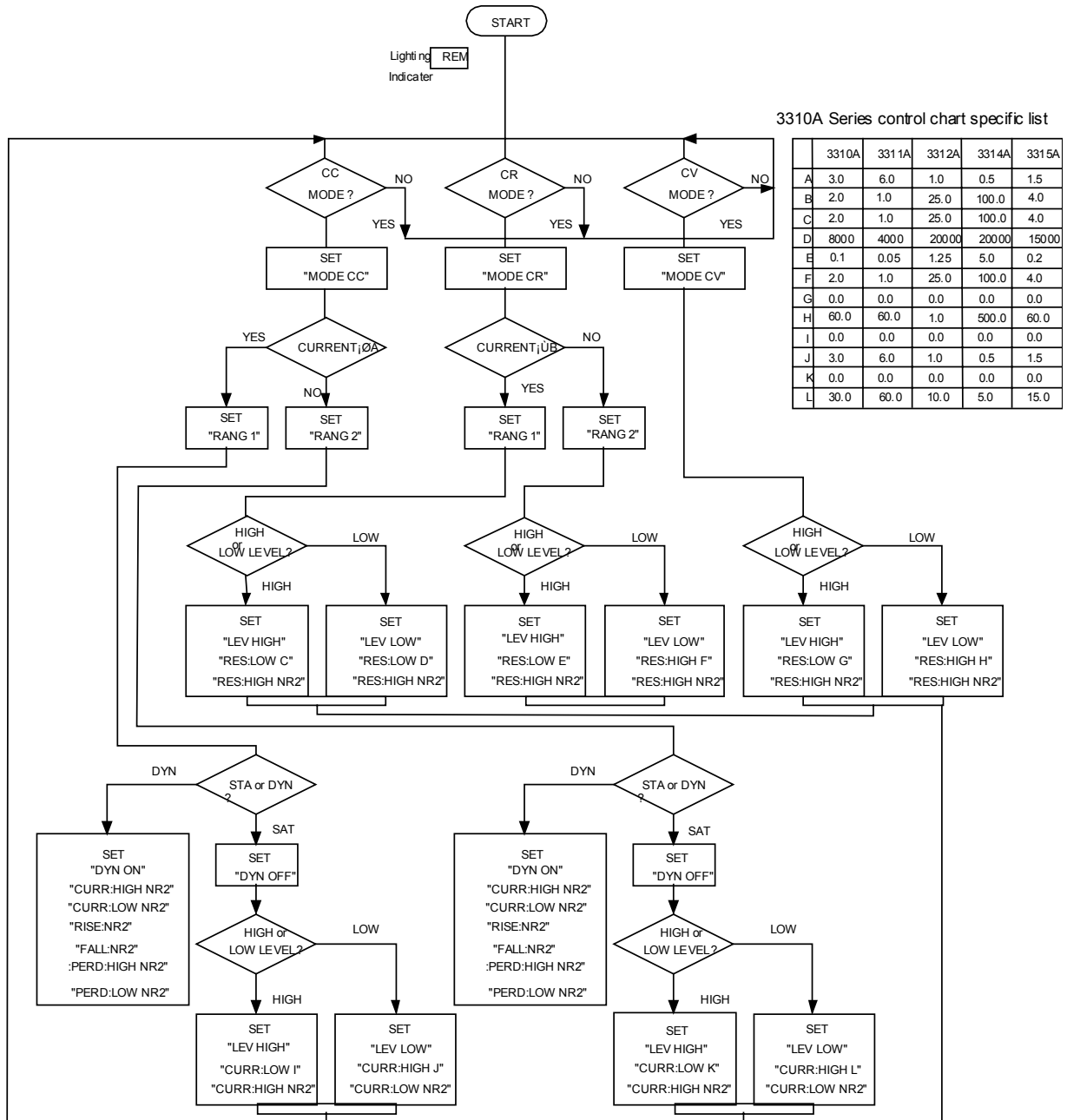

Appendix E 3330A Series GPIB/RS-232 Operating flow chart

The following flow chart shows the typical 3300C Series mainframe remote control and load current level and status setting procedures of each 3330A series load module.

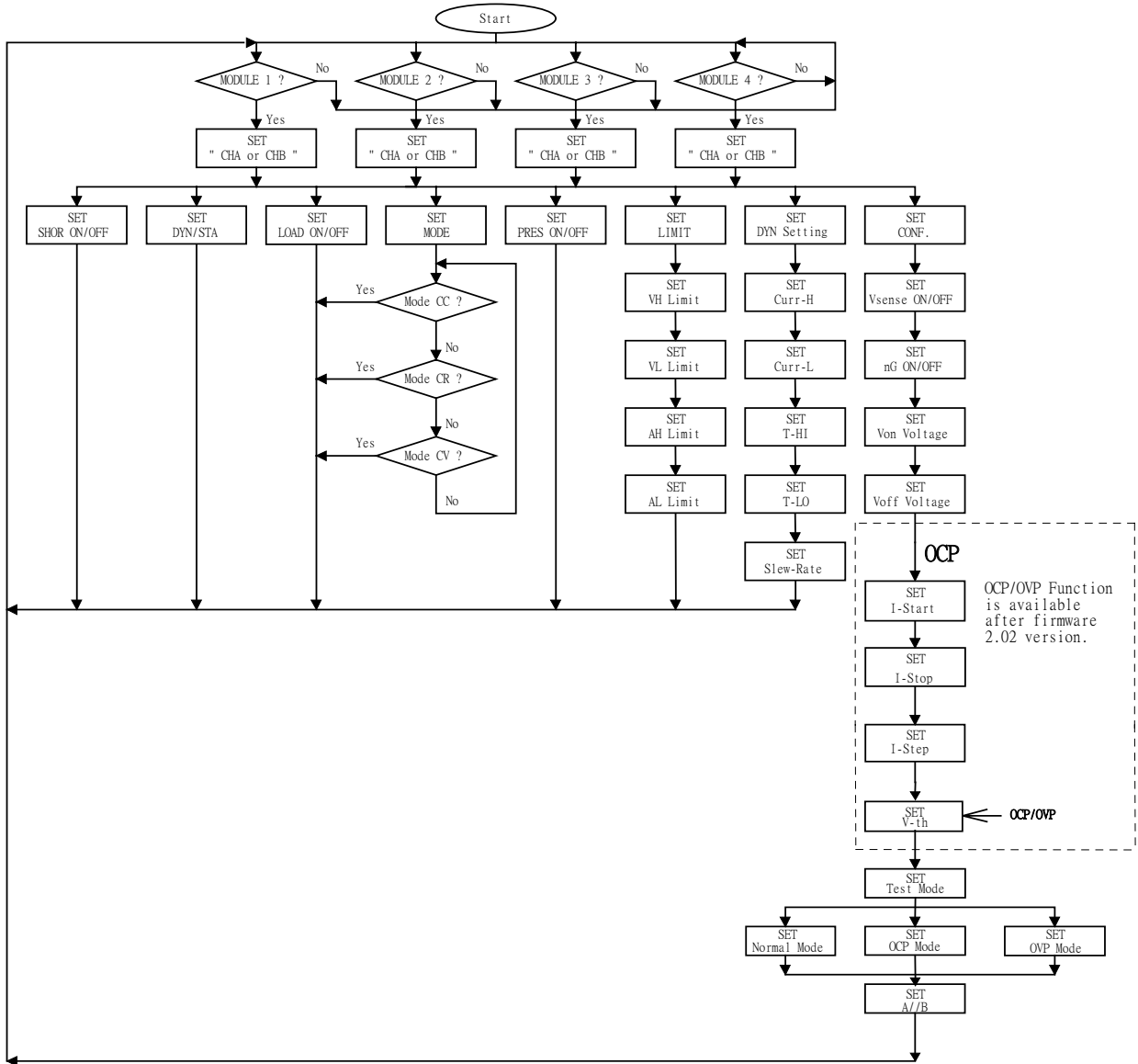

Appendix F 3310C Series GPIB/RS-232 Operating flow chart

The following flow chart shows the typical 3300C Series mainframe remote control and load current level and status setting procedures of each 3310C series load module.

