

OPERATING MANUAL  
SPP Series  
PEN PROBES



**Model SPP1: Single-Point Pen Probe**



**Model SPP2: Two-Point Pen Probe**



**Model SPP3: Concentric Pen Probe**

## Table of Contents

UNPACKING AND INSPECTION.....	2
KIT CONTENTS .....	3
WARRANTY INFORMATION .....	4
SHIPPING OF WARRANTY RETURNS.....	5
PRODUCT SPEC.....	6
INTRODUCTION .....	7
MODEL SPP1: SINGLE-POINT PEN PROBE.....	9
MODEL SPP2: TWO-POINT PEN PROBE .....	15
MODEL SPP3: CONCENTRIC PEN PROBE.....	18
MAINTENANCE.....	20

### UNPACKING AND INSPECTION

Examine the shipping container for obvious signs of damage.

If damage is suspected, open the container and inspect the instrument for possible damage.

If damage is noted, notify the carrier and supplier (your local rep.) immediately.

If instruments appear to be in good condition:

Read the Operator's Manual in its entirety.

Check and verify that all items are included with the kit, then conduct a series of familiarization tests as instructed in the Operation Manual.

## **KIT CONTENTS**

### **Model SPP1: Single-Point Pen Probe Kit**

Kit Consists of:

- 1 Each Pen Probe Body
- 1 Each Pogo Pin Probe
- 1 Each Conductive Rubber Boot
- 1 Each Spare Pogo Pin Probe
- 1 Each Spare Conductive Rubber Boot

### **Model SPP2: Two-Point Pen Probe Kit**

Kit Consists of:

- 1 Each Pen Probe Body
- 2 Each Pogo Pin Probes
- 2 Each Conductive Rubber Boot
- 1 Each BNC-To-Banana Adapter
- 1 Spare Pogo Pin Probe
- 2 Spare Conductive Rubber Boots

### **Model SPP3: Concentric Pen Probe**

Kit Consists of:

- 1 Each Pen Probe Body
- Concentric Pogo Pin Probes
- 2 Each Conductive Rubber Boot/Ring
- 1 Each BNC-To-Banana Adapter
- 1 Each Large and 2 Each Small Spare Pogo Pin Probes
- 1 Each Spare Conductive Rubber Boot and Ring.

## **WARRANTY INFORMATION**

### ***STATICO*<sup>TM</sup> Warranty**

***STATICO*<sup>TM</sup>** Corporation expressly warrants that for a period of one (1) year from the date of purchase, that ***STATICO*<sup>TM</sup>** instruments will be free of defects in material (parts) and workmanship (labor). If ***STATICO*<sup>TM</sup>** receives notice of such defect during the warranty period, ***STATICO*<sup>TM</sup>** will replace at its expense such parts which it determines to be defective. Any defective part must be returned to ***STATICO*<sup>TM</sup>** postage prepaid with proof of purchase date.

### **Warranty Exclusions –**

**THE FOREGOING EXPRESS WARRANTY IS MADE IN LIEU OF ALL OTHER PRODUCT WARRANTIES, EXPRESS AND IMPLIED, INCLUDING MERCHANTABILITY AND FITNESS FOR A PARTICULAR PURPOSE, WHICH ARE SPECIFICALLY DISCLAIMED.**

The express warranty will not apply to defects or damage due to accidents, neglect, misuse, alterations, operator error, or failure to properly maintain, clean, or repair products. Limit of Liability - In no event will ***STATICO*<sup>TM</sup>** or any seller be responsible or liable for special, incidental, or consequential losses or damages, under any legal theory including but not limited to contract, negligence, or strict liability.

Fulfillment by ***STATICO*<sup>TM</sup>** of its express warranty obligations described above will be purchaser's exclusive remedy and will be ***STATICO*<sup>TM</sup>**'s and seller's limit of liability for any breach of warranty or otherwise.

## **SHIPPING OF WARRANTY RETURNS**

Obtain a Return Authorization Number and shipping address from *STATICO*<sup>™</sup> customer service.

Pack the Instrument carefully and ship it prepaid and insured to the proper destination provided by *STATICO*<sup>™</sup>'s customer service department.

<p><b>DO NOT RETURN ANY ITEM WITHOUT HAVING FIRST RECEIVED RETURN AUTHORIZATION FROM <i>STATICO</i>.</b></p>
--

For Detailed Shipping Instructions and Return Authorization, Contact:

The following information must be included with the returned product:

Description of the problem

Purchase Order number & *STATICO*<sup>™</sup> Return Authorization Number

Name and phone number of contact individual who can provide more information.

Complete return address

## **SHIPPING OF NON-WARRANTY RETURNS**

Any product returned for non-warranty repair should be packaged as described previously. Obtain a Return Authorization Number and shipped to the address provided by *STATICO* Customer Service.

## Product Specifications

### Pen Probes

Probe End Colors	Black
Probe Body Color	Various
Dielectric Material	Black ABS
Contact Probe	
Material	Nickle/silver, gold plated
Diameter	0.100" (2.54mm)
Preload Spring Force (ea.)	2.90 oz (82 g)
Max. Travel	0.25" (6.4mm)
Contact Boot	
Material	Conductive Rubber
Diameter	0.125" (3.13mm)
Minimum Sample Size	0.350" (8.9mm)
Usable Resistance Test Range	
With Rubber Boots	$1 \times 10^4$ to $2 \times 10^{12}$ Ohms
Bare Probe Pins	1 ohm to $2 \times 10^{12}$ Ohms
Test Methods	ASTM-D-257
Connection	
BNC to Banana Receptacle	
Works with most Meg-ohmmeter with banana jack cords.	
Probe Dimensions	
2-Point and Concentric	8.5" (220mm) long, incl. cap.
1-Point	6.75" (171 mm) long, incl. cap.
Probe Body Diameter	0.50" (12.7mm)
Weight	Less than 2 oz (50 g)

**Model SPP1: Single-Point Pen Probe**  
**Model SPP2: Two-Point Pen Probe**  
**Model SPP3: Concentric Pen Probe**

## **INTRODUCTION**

MODEL SPP1: Single-Point Pen Probe, MODEL SPP2: Two-Point Pen Probe, and MODEL SPP3: Concentric Pen Probes work with most megohm meters, electrometers and other high potential resistance meters in most Resistance Kits for measuring Surface Resistance and Volume Resistance of materials with physical dimensions too small for regular concentric ring or other probes. The size, portability and construction make these probes convenient for auditing small samples of materials in the field and yet their design specifications make these instruments precision enough for laboratory environments.

SPP1, SPP2 and SPP3 Pen Probes use spring loaded electrodes with conductive rubber boots to ensure intimate contact with hard/irregular surfaces and reduce contact resistance. All electrodes are field-replaceable, spring-loaded, pogo-pin type ATE-quality probes that are made of beryllium copper with minimum 60 micro-inch hard gold.

The Single-Point Pen Probe can be used for measuring volume resistance of small planar material sample per the requirements of ANSI/ESDA 11.12 or measuring resistance to ground of materials or component on a piece of equipment.

Direct point-to-point resistance measurements with *STATICO* Two-Point Pen Probe, SPP2, generally conform to the guidelines as outlined in the ANSI/ESDA 11.13 Two-Point Resistance Measurements.

The Two-Point Pen Probe uses a thin line BNC coaxial cable with inner source and outer sense connections to minimize reading errors due to electrostatic interference. The BNC to banana jack adapter allows connection to most popular meters in the market.

## **CAUTIONS -- WARNINGS**

As with any electrical device, use proper electrical precautions to avoid personnel shock.

The SPP1, SPP2 and SPP3 Pen Probes operate with power input from the megohm meters at 10 to 100 volts, and is capable of delivering an annoying shock to any person touching it.

Although the current capability is limited, a distinct HAZARD EXISTS in the person's reaction to the shock.

To avoid personnel shock, do not touch the electrodes or contact boots on the SPP1, SPP2 and SPP3 when power is applied to the probes.



# Model SPP1 – SINGLE-POINT PEN PROBE

## Volume Resistance Measurement for Planar materials

### Introduction:

Volume resistance measurements determine if the material has electrical conducting properties through the bulk of the sample. This test will measure resistance from top surface to bottom surface of the sample. There are several possible current paths that the user should understand and determine which one or combinations of which give the final reading as shown on the schematic below by Ben Baumgartner (ESDiscovery 2000).

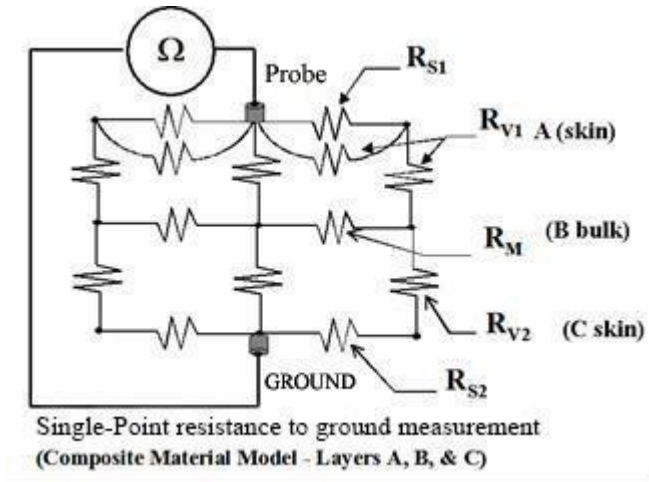

As shown above, the test current can go along the top surface, around the edges, through the bulk material at various points, within the material or across the bottom surface before reaching the bottom ground plane.

To ensure that the edges do not contribute to the reading, it is best to cut the sample into one smaller piece so that none of the outside vertical edges exists. In this way, the only way the current can flow is down, not going around along the surfaces.

### Procedures:

1. Place sample to be tested on a conductive platform such as stainless steel or copper plate.
2. For best result, the platform should be thick enough to accommodate a hole for a banana jack.

3. Connect the negative (-) terminal to the test platform.



4. Plug one end of the cord, provided with the SPP1 Kit, to the Single-Point Pen Probe.



5. Connect the other end of the coiled cord to the positive (+) terminal of your megohm meter. If your meter comes with cables that end with a banana plug, use that cable and plug into the Single-Point Pen Probe.



6. Make sure that the conductive rubber boot is secure on the probe pin.

7. Hold the Pen Probe vertically and place the rubber tip on the sample.



8. Apply pressure and compress the pogo pin until the probe body is about 1/8" of an inch from the rubber boot. This would provide the sufficient pressure for correct contact force.



9. Apply to test voltage from your meter to read the sample volume resistance per ANSI/ESDA 11.12.
10. Note: Volume resistance is shown as the reading from the meter (in ohms) divided by the material thickness and shown in ohm-cm or ohm-inch.

## MODEL SPP1: SINGLE-POINT PEN PROBE

### Resistance to ground measurement for small piece parts

#### Introduction:

This test will measure resistance from various points on the top surface of the piece part to the conductive platform that the bottom surface of the sample is sitting on. The purpose of this test is to determine the ability of the piece part to dissipate electrostatic charge from its surface to a fixture or tool. The same possible current paths as the last section and all of them will contribute to the charge dissipation characteristics of the sample, as shown on the schematic below by Ben Baumgartner (ESDiscovery 2000).

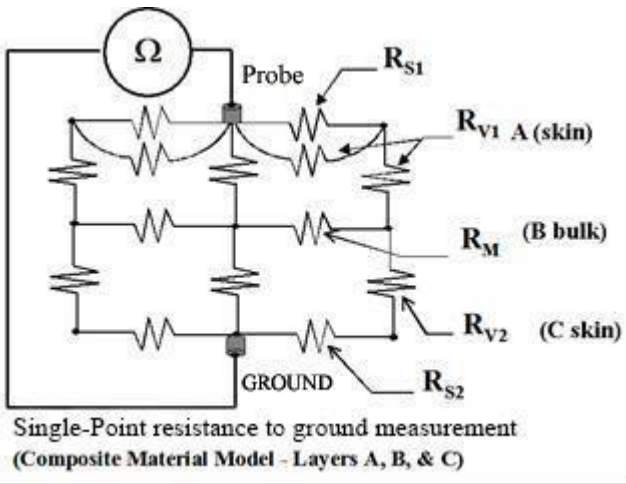

In this case, however, we want the edges to contribute to the readings. For best result, the conductive platform should be larger than the sample.

Procedures: Test procedure is the same as that for planar materials.

## MODEL SPP1: SINGLE-POINT PEN PROBE

### Resistance to Ground Measurement for Equipment

#### Introduction:

Resistance to ground measurements for equipment determines if the material installed in the production equipment has the ability to dissipate electrostatic to the equipment ground. This test will measure resistance from machine parts to the equipment chassis ground. It is recommended to measure all machine parts within 12" ESD sensitive product handling path per ANSI/ESDA 10.1, Automated Handlers.

For metal machine parts, an ohmmeter or the ohmmeter function of a DVM can be used.

For coated or non-metallic machine parts, a megohm meter with applied voltage of 10 volts or 100 volts as appropriate can be used.

#### Procedures:

1. Connect the negative (-) terminal of your meter (ohmmeter or megohmmeter) to the equipment chassis ground.
2. Connect the positive (+) terminal of your meter (ohmmeter or Megohm meter) to the Single-Point Pen Probe.



**Note:** When using the megohmmeter, the probe tip may be energized up to 100 volts. Make sure that sensitive products are not placed nearby the probe tip. Do not touch the probe tip with your hand. Do not touch the probe tip to sensitive products.

3. For metallic machine parts: Use an ohmmeter. Remove the conductive rubber tip for the probe tip.
4. Set the ohmmeter to auto range or to the lowest range of ohm reading.
5. Touch the bare (gold color) probe tip to various points on metallic machine parts.

6. Apply pressure and compress the pogo pin until the probe body is about 1/8" of an inch from the top of the pin contact. This would provide the sufficient pressure for correct contact force.
7. Record measurements.  
**Note:** A properly grounded metallic machine part should have its resistance to ground reading less than 1 ohm.
8. For coated or non-metallic machine parts: Use a megohmmeter. Make sure that the conductive rubber tip is installed.
9. Set the applied voltage to 100 volts. Touch the probe tip to non-metallic machine parts.
10. Apply pressure and compress the pogo pin until the probe body is about 1/8" of an inch from the rubber boot. This would provide the sufficient pressure for correct contact force.
11. Record measurements.  
**Note:** A properly grounded static dissipative or ESD coated machine part should have its resistance to ground reading less than  $1 \times 10^{11}$  ohms.

## MODEL SPP2: TWO-POINT PENT PROBE

### Point-to-Point Resistance Measurement for Materials

#### Introduction:

Point-to-point resistance measurements for planar material characterize the ability of a planar (flat) sample to conduct electricity and electrostatic charge from one point to another along the top-most layer of the material. For thick samples with bulk conductivity, the resultant reading can come from many paths of current flows, as shown below. (Courtesy Ben Baumgartner, ESDcovery 2000)

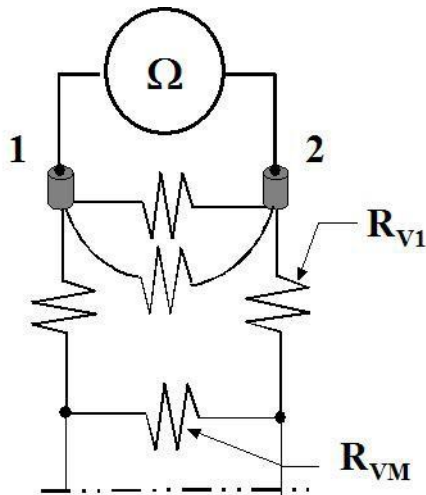

#### 2-Point Surface Res. Measurement Material with finite thickness

This test is designed to check for hot spots on a sample of a finish product where the NFPA probes (5lbs weights) are too large to detect or to fit on the sample.

#### Procedures:

1. Place sample to be tested on an insulative platform such as plastic or acrylic plate.

2. Install the BNC-to-Banana adapter to the end of the probe.



3. Connect banana jack cables to the probe adaptor.



3. Connect the other ends of the cables to the Mega-ohmmeter.



4. Make sure that the conductive rubber boot is secure on the probe pins.



5. Hold the Pen Probe vertically and place the rubber tips on the sample.

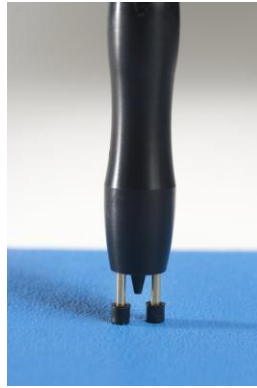

6. Apply pressure and compress the pogo pins until the probe runs against the dead stop. This would provide the sufficient pressure for correct contact force.



7. Apply to test voltage from your meter to read the sample volume resistance per ANSI/ESDA 11.13.

**MODEL S103PP: CONCENTRIC PEN PROBE**  
**Surface Resistance Measurement for Materials**

Introduction:

Surface resistance measurements for planar material characterize the resistance (and resistivity) of a planar (flat) sample.

(Courtesy Ben Baumgartner, ESDicoverly 2000)

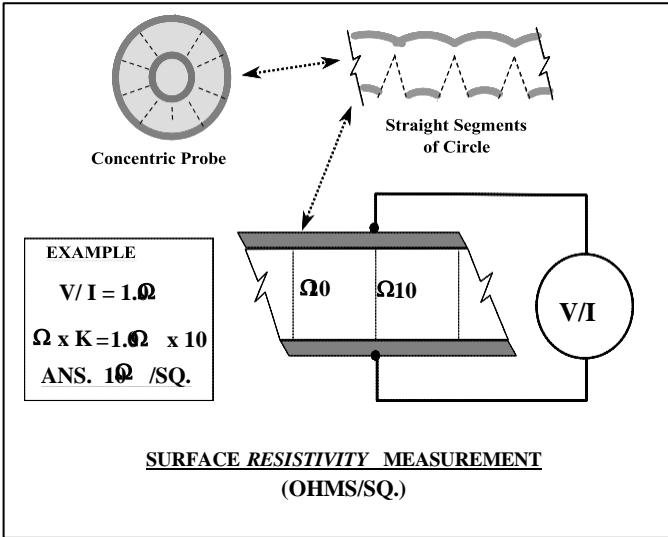

This test is designed to check for hot spots on a sample of a finish product where the NFPA probes (5lbs weights) are too large to detect or to fit on the sample.

Procedures:

1. Place sample to be tested on an insulative platform such as plastic or acrylic plate.
2. Connect Coaxial adaptor to the end of the probe.



3. Connect one end banana jack cables to the probe adapter.



4. Connect the other ends of the cables to the Mega-ohmmeter.



5. Make sure that the conductive rubber boot is secure on the probe pins.

- 6 Hold the Pen Probe vertically and place the rubber tips on the sample.



- 7 Apply pressure and compress the pogo pins until the rubber ring on the probe runs against the probe body. This would provide the sufficient pressure for correct contact force.

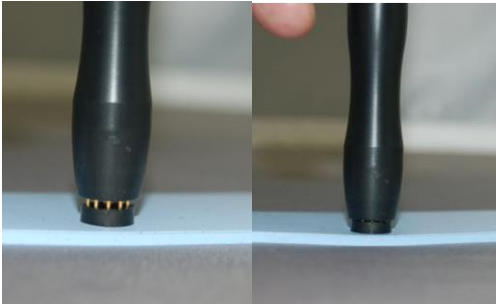

- 8 Apply to test voltage from your meter to read the sample volume resistance per ANSI/ESDA 11.13.

## **MAINTENANCE**

Wipe conductive rubber probe tip(s) with a lint-free tissue moistened with IPA periodically to remove contaminants.

Keep probe in a dry and cool place when not used.

Do not submerge probe in any liquid.

## Revision Records

Rev. A June 30, 2020:

Correct typo on page 13:

“Connect the positive (+) terminal of your meter (ohmmeter or Megohm meter) to the Single-Point Pen Probe.”

Copyright © 2014 by *STATICO*. All rights reserved.  
Printed in the United States of America. No part of this manual may be used or reproduced in any manner whatsoever without written permission. For information, contact *STATICO*.