

## ATS-710-T THERMOSTREAM®

**-80° to +225°C**

Advanced Temperature Source for fast and precise thermal conditioning of components, parts, hybrids, modules, subassemblies, and printed circuit boards. Capable of ultra-low temperatures **without** the use of Liquid Nitrogen (LN<sub>2</sub>) or Liquid Carbon Dioxide (LCO<sub>2</sub>).

### PERFORMANCE:

#### Temperature Range\*

-75 to +225°C (50Hz)

-80 to +225°C (60Hz)

No LN<sub>2</sub> or LCO<sub>2</sub> Required

#### Transition Rate\*

-55 to +125°C, approx. 10 seconds or less

125 to -55°C, approx. 10 seconds or less

#### System Airflow Output\*

4 to 18scfm (1.9 to 8.5 l/s) Continuous

\*under nominal operating conditions

ultimate low temperatures (±1°) achieved at 12scfm

### TEMPERATURE CONTROL:

#### Temperature Display & Resolution

+/- 0.1°C

#### Temperature Accuracy

1.0°C (when calibrated against NIST standard)

#### DUT Temperature Control

Proprietary control algorithm enables DUT temperature to be directly controlled

#### DUT Sensor Ports

Internal diode, thermocouples (T & K), RTD (100 Ohm platinum)



System shown with optional enclosure

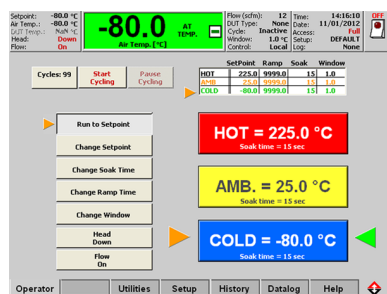

OPERATOR SCREEN

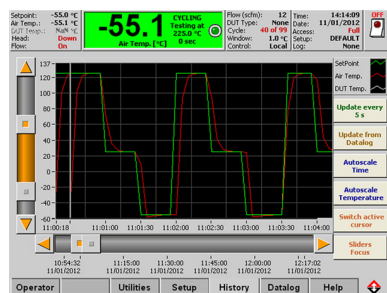

DATALOG SCREEN

### FEATURES:

#### Frost Free Feature

Dry air purge for tester interface, prevents condensation: 0.5 to 3scfm (0.25 to 1.5 l/s)

#### ECO Friendly Features

- Automatic Power Reduction: reduces power usage during idle periods
- Heat Only Mode: reduces power usage when cold temperatures are not used

#### Heated Defrost Feature

Quickly removes moisture buildup from internal chiller

#### Fully Adjustable Thermal Head

- Windows® OS
- Local & Remote Operations
- LabView™ & LabWindows® drivers
- On-Screen Help
- Ethernet, IEEE-488, RS232 ports
- USB, keyboard, mouse, & printer ports
- Customizable and savable test setups
- Program & Datalog Storage (via ethernet or USB)
- User Defined Temperature Limits

### APPLICATION OPTIONS:

#### Thermal Cap or FlexExtender Hose

4.5 or 5.5 inch ID Thermal Cap or optional FlexExtender Hose for connection to external Thermal Chambers or enclosures

#### MobileTemp™ Thermal Chambers

Temperature Chambers designed specifically for uses with ATS THERMOSTREAM® Systems. See Additional Datasheets for details.



## SYSTEM DIMENSIONS STANDARD

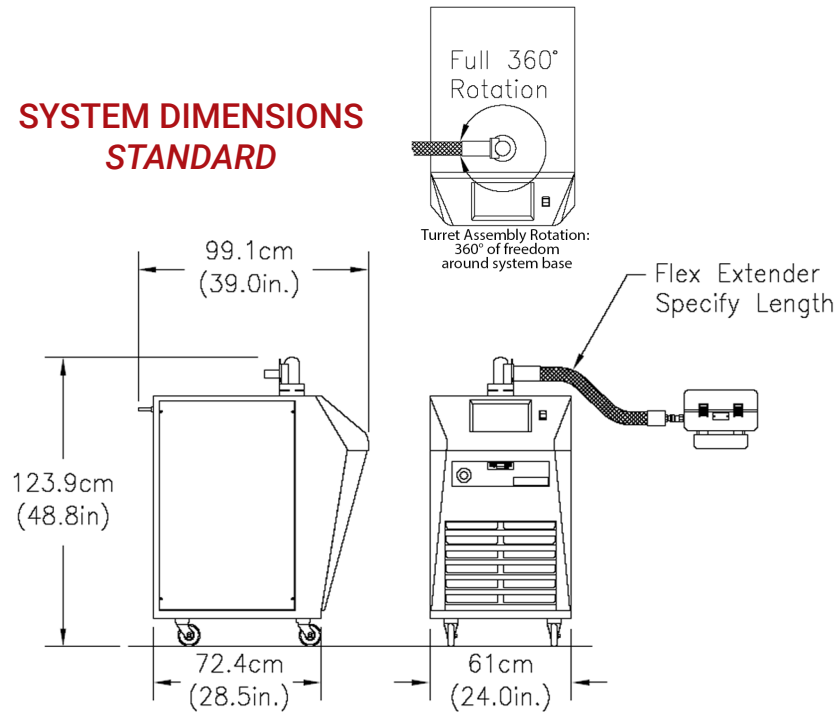

## FACILITY REQUIREMENTS

Power <sup>1</sup>	200 - 250 VAC (230V nominal), 50/60Hz, 30 amp, 1phase
<b>COMPRESSED AIR<sup>2</sup></b>	
Clean, Dry Air (CDA)	Filtered to 5 micron particulate contamination. Oil Content: <0.1 ppm, by weight, filtered to 0.01 micron oil contaminant. Dewpoint: <10°C @ 6.2 BAR (90PSI)
Air Supply Pressure	6.2 to 7.6 BAR (90 to 110 PSIG)
Total Air Flow Rate Required	7.1 to 14.2 l/s (15-30 scfm), 11.8 l/s (25 scfm) nominal
Air Supply Temperature	+20° to +25°C; +22°C nominal
<b>OPERATING ENVIRONMENT<sup>2</sup></b>	
Operating Temperature	+20° to +28°C; +23°C nominal
Humidity	0 to 60%; 45% nominal

## WEIGHTS & DIMENSIONS

Base <sup>3</sup>	Width: 61.0 cm (24 in.), Depth: 72.4 cm (28.5 in.), Height: 123.9 cm (48.8 in.)
System Weight	Not packed: 226 kg (500 lbs.), Packed: 341 kg (762 lbs.)
Mobility	Four static dissipative, swivel caster wheels
FlexExtender Length	FlexExtender hose available in 1', 2', and 4' standard lengths, custom lengths available
Noise Level	<65dBA

## SERVICE & SAFETY

Refrigerants	HCFC and CFC-free, non-toxic, non-flammable
Serviceability	Auto-diagnostics and field replaceable modules
Over Temperature Protection	+230°C (factory set): Operator can set high and low air temperature limits

<sup>1</sup>System is configured for operation within voltages listed above using an internal transformer. Please specify power configuration with order

<sup>2</sup>Under operating conditions which are greater or less than nominal, performance may be less than specification provided

<sup>3</sup>An additional 20.3cm (8 in.) clearance is required for supply connections and cabinet ventilation

