



testo 350-MARITIME

Instruction manual

en





- A. Safety instructions5**
- B. Intended purpose7**
 - B.1 Hazard warnings for testo 350-MARITIME9
 - B.2 Menu guidance for testo 350-MARITIME11
 - B.2.1 Control unit11
 - B.2.2 Flue gas analyzer13
- C. Product description14**
 - C.1 Scope of delivery14
 - C.2 Control unit15
 - C.2.1 Overview of control unit15
 - C.2.2 Keyboard16
 - C.2.3 Display16
 - C.2.4 Setting the automatic switch-off19
 - C.2.5 Changing units20
 - C.2.6 Showing/hiding integrated differential pressure probe20
 - C.2.7 Control unit connections/interfaces20
 - C.2.8 Control unit power supply21
 - C.2.9 Air probe (temperature and humidity)21
 - C.3 Flue gas analyzer22
 - C.3.1 Flue gas analyzer overview22
 - C.3.2 LED status display23
 - C.3.3 Flue gas analyzer connections/interfaces23
 - C.3.4 Flue gas analyzer power supply24
 - C.3.5 Voltage input24
 - C.3.6 Instrument options24
 - C.4.1 Positive pressure terminal26
- D. Commissioning26**
- E. Operation27**
 - E.1 Mains unit, batteries/rechargeable batteries27
 - E.1.1 Changing batteries/rechargeable batteries27
 - E.1.2 Charging the battery28
 - E.1.3 Mains operation (110/230 V, 47 - 63 Hz)29
 - E.1.4 Operation with DC voltage (11 V - 40 V DC)29
 - E.2 Probes/sensors30
 - E.2.1 Connecting probes/sensors30
 - E.2.2 Positioning flue gas probe30
 - E.2.3 Options for securing the flue gas probe31
 - E.2.4 Vibrations33

E.3	Basic operating steps	34
E.3.1	Connecting the control unit to the flue gas analyzer	34
E.3.2	Switching on the flue gas analyzer	34
E.3.3	Calling up a function	35
E.3.4	Assigning a function key	36
E.3.5	Air humidity/temperature of engine intake air	37
E.3.6	Printing data	38
E.3.7	Saving data	39
E.3.8	Switching off the flue gas analyzer	39
E.4	Setting the measuring system up	40
E.4.1	Setting the language	40
E.4.2	Setting the date/time	40
E.4.3	Setting the fuel	41
E.4.4	Changing the display sequence	42
E.4.5	Setting up locations	43
E.4.6	Changing the instrument name	44
E.4.7	Set up printer	44
F.	Main menu	45
F.1	Control unit	45
F.1.1	Probes	45
F.1.2	Instrument	47
F.1.3	Service	49
F.2	Flue gas analyzer	50
F.2.1	Memory	50
F.2.2	Sensors	54
F.2.3	Input	58
F.2.4.	Instrument	60
F.2.5	Service	60
G.	Measuring	62
G.1	Preparing measurements	62
G.2	Flue gas measurement	62
G.2.1	Performing an individual or spot measurement	62
G.2.2	Carrying out a measurement program	63
G.3	Differential pressure measurement	64
G.4	Velocity measurement	65



H.	Care and maintenance	66
H.1	Cleaning the flue gas analyzer	66
H.2	Changing/retrofitting sensors	66
H.3	Calibrating/readjusting the sensors	67
H.4	Cleaning the flue gas probe	67
H.5	Replacing thermocouple	68
H.6	Changing the printer paper	69
H.7	Changing the batteries/rechargeable batteries	69
H.8	Condensate container	69
H.9	Checking/replacing the particle filter	70
H.10	Cleaning/changing the pumps	70
H.10.1	Cleaning the main gas pump	71
H.10.2	Cleaning the purging pump/conveying pump for diluting gas ..	71
H.10.3	Changing the condensate pump	73
H.11	Changing the filter fleece in the gas cooler	73
H.12	Checking flue gas analyzer for leaks	74
H.13	Recommended maintenance cycles	74
I.	Questions and answers	75
J.	Technical data	76
J.1	Checks and certifications	76
J.2	Measuring ranges and accuracies	90
J.3	Other instrument data	91
J.4	Recommended rinse times	92
J.5	Principles of calculation	93
J.5.1	Fuel parameters	93
K.	Accessories / Spare parts	94

A. Safety instructions

Avoid electrical hazards:

- ▶ Never use the measuring instrument and probes to measure on or near live parts!

Protect the measuring instrument:

- ▶ Never store the measuring instrument/measuring cells together with solvents (e.g. acetone). Do not use any desiccants.

Product safety/preserving warranty claims:

- ▶ Operate the measuring instrument only within the parameters specified in the Technical data.
- ▶ Handle the measuring instrument properly and according to its intended purpose only.
- ▶ The measuring instrument must not be placed on surfaces subject to extremely high vibration.
- ▶ Before use: It is imperative that you observe the fitting instructions for the flue gas probe.
- ▶ To avoid damage to the instrument, the engine system or persons from strong vibration of the flue gas duct, the gas sampling probe must be secured so that it cannot work itself loose. It must be ensured that the probe is positioned so that any parts working themselves loose cannot come into contact with moving components of the machine system.
- ▶ The measuring instrument must always be operated in its case.
- ▶ At the end of the measuring, remove the gas sampling probe from the flue gas duct and seal the sampling point.
- ▶ Never apply force!
- ▶ Temperatures given on probes/sensors relate only to the measuring range of the sensors. Do not expose handles and feed lines to any temperatures in excess of 70 °C unless they are expressly permitted for higher temperatures.
- ▶ Open the measuring instrument only when this is expressly described in the Operating Instructions for maintenance purposes.
- ▶ Carry out only the maintenance and repair work that is described in the instruction manual. Follow the prescribed steps exactly. For safety reasons, use only original spare parts from Testo.



6 A. Safety instructions

Any additional work must only be carried out by authorized personnel. Testo will otherwise refuse to accept responsibility for the proper functioning of the measuring instrument after repair and for the validity of certifications.



Ensure correct disposal:

- ▶ Dispose of defective rechargeable batteries and spent batteries at the designated collection points.
- ▶ Send the measuring instrument directly to us at the end of its useful life. We will ensure that it is disposed of in an environmentally friendly manner.

B. Intended purpose

This chapter describes the areas of application for which the measuring instrument is intended.

The testo 350-MARITIME must not be used for continuous flue gas measurements, i.e. the sensors must be rinsed regularly with fresh air. For the recommended measuring and rinse times refer to chapter J.4 Recommended rinse times.

The testo 350-MARITIME is a portable flue gas analyzer that can be used to measure the flue gas emissions of ship diesel engines as a component in a holistic monitoring system in accordance with MARPOL 73/78 Annex VI and the NO_x Technical Code (MEPC.177(58)).

In order to correspond fully to the on-board verification method contained in the “direct measuring and monitoring method” (in accordance with MARPOL 73/78 Annex VI and the NO_x Technical Code (MEPC.177(58))), additional parameters must also be recorded.

The testo 350-MARITIME was designed for the following tasks/applications:

- **The testo 350-MARITIME can be used to measure the gaseous flue gas concentrations of O₂, CO, CO₂, NO_x and SO₂ as a system component for the following methods:**
 - For periodic and interim tests for measuring and monitoring directly on board.
 - As a component for a simplified test and measuring method (HC must be measured separately)
 - If, for example, a readjustment or other modification has been performed on an engine
- **Checking the NO_x limit values specified in MARPOL Annex VI**
 - For official NO_x check measurements on board
- **Measuring NO_x as verification in special regional zones**
 - E.g. as proof of reduction of NO_x for NO_x tax in Norway

! The testo 350-MARITIME flue gas analyzer is certified by Germanischer Lloyd (GL) and DET NORSKE VERITAS (DNV) for measuring the gaseous flue gas components of O₂, CO, CO₂, **NO_x and SO₂** as a system component (e.g. for the method of measuring and monitoring directly on board, and for the simplified measuring method).



8 B. Intended purpose

- ! Other system components that are required for the method of measuring and monitoring directly on board in accordance with the NOx Technical Code are not included in this certifications!
- ! The use of a monitoring system and its measurement results are subject to the prior consent of the respective Flag State.

B.1 Hazard warnings for testo 350-MARITIME

Description	People	Hazard to system	Instrument
Power supply Disconnecting the protective conductor by any means inside or outside the instrument is prohibited! Check against the type plate that the type, mains voltage and power correspond to the actual specifications	X		X
Disposing of measuring cells The measuring cells contain small quantities of concentrated acids. Dispose of these as special waste! Hazard in the event of improper use!	X		
Storing the measuring instrument Never store the measuring instrument in rooms with solvents. Danger of destruction of the measuring cells! Ensure that the permissible storage, transport and operating temperatures are observed.		X	
Rechargeable battery Charge the rechargeable battery fully before the first measurement and after several days of disuse. Recharge the rechargeable battery every 4 weeks during long periods of disuse. The testo monobloc rechargeable battery for control units must be inserted so that the lettering is visible on the top. Otherwise, if the insulating film is damaged, there is a risk of short-circuit and polarity reversal.		X	
Using the probe When removing the probe from the flue gas duct, remember that the probe will be hot!	X		
Condensation outlet Aggressive condensate (acid) escapes from the condensation outlet. Unless an appropriate drain (e.g. hose) is used, this constitutes a hazard to materials and the user!	X		X
Service and maintenance The mains plug must always be disconnected before the housing is opened. Danger of electric shocks. Only authorized persons may carry out work inside the instrument!	X	X	X



B. Intended purpose
 B.1 Hazard warnings for testo 350-MARITIME

Description	People	Hazard to system	Instrument
Proscribed measurements Gases which are explosive or flammable or which form inflammable mixtures with atmospheric air must not be measured with this instrument.	X		
Pressure of the test gases The maximum permissible pressure is 50 mbar. Higher pressures may destroy the gas sensors. In addition to this, test gas may only be used in well ventilated rooms.	X		X
Cleaning the instrument It is essential to prevent water from penetrating inside the instrument.			X
Differential pressure probe When making measurements, observe the permissible measuring ranges. Exceeding the measuring range will destroy the sensor.			X
Condensation Condensation on the instrument and the instrument electronics must be avoided.			X
Measuring in enclosed spaces Take measures to ensure sufficient ventilation, danger of poisoning!	X		
Overall system Measurements must not be performed on live parts in any part of the system. Danger of electric shocks. Protect system against overvoltage.	X		X
CO measurement Adequate ventilation must be ensured when measuring toxic gases (CO). Danger of poisoning.	X		
Power supply of the overall system Always ensure that the overall system has an adequate power supply (new or charged batteries, mains unit). Risk of instability of the overall system.			X
EMC Under the effects of increased electromagnetic activity, the readings may deviate from standard specifications. Hazard if the analogue/switch outputs are connected! A protective conductor must be connected to the socket. The temperature display with control unit and separate probe can jump by up to 2 °C if a thermocouple with an earth contact is connected in conjunction with a switched-mode power supply.	X	X	

B.2 Menu guidance for testo 350-MARITIME

B.2.1 Control unit

Level 1	Level 2	Level 3	Level 4	Level 5	
Probe	Damping	Internal sensor	Values from		
		Sensor socket 1			
		Surface increment			
		Temp. probe adjustment			
		Hum. probe adjustment			
	Scaling	Sensor socket 1	Min. input		
			Max. input		
			Min. output		
			Max. output		
			Unit	°C, %, m/s, m ³ /h, hPa, ppm, m, ppm, kHz, pH, mS, bar	
			Decimal places	0, 1, 2	
			Information		
			Save		
	Reset	Internal sensor	Sensor socket 1		
			All probes		
Information					
Information	Internal sensor	Sensor socket 1			
Instrument	Change date				
	Auto off	Off, 5 min, 10 min, 15 min, 20 min, 25 min, 30 min.			
	Printer	Contrast			
		Pressure	Line 1, line 2, line 3, footer		
	Light	On/off			
		Automatic			
	Diagnosis				
	Units	Temperature	°C, °F		
		Humidity	Off, td°C, g/m ³ , g/kg, J/g		
		Pressure	hPa, inW, mbar, Pa, bar, psi mmWs, Torr, InHg, kPa		
	Configuration	Internal pressure sensor	Show pressure sensor		
			Hide pressure sensor		
Scroll instruments			Current instrument		
		All instruments			



12 B. Intended purpose
B.2 Menu guidance for testo 350-MARITIME

Level 1	Level 2	Level 3	Level 4	Level 5
Service	Operating values			
	Reset Factory	No		
		Yes		
	Address			
	Instrument data			
	Language	German		
		English		

B.2.2 Flue gas analyzer

Level 1	Level 2	Level 3	Level 4	Level 5	
Memory	Reading out Program	Measurement program 1	Start	Manual Date/time	
			Mean value	No Yes	
				Measuring rate	
			End		Memory full No. readings Date/time
			Gas time		
			Rinse time		
			Information		
			Save		
			Delete		
			Measurement program 2	<i>see measurement program 1</i>	
		Deleting memory	No Yes		
	Free memory				
Sensors	Recal.	CO, NO, NO ₂ , (SO ₂), CO ₂			
	Sensor status				
	Printing sensor data				
Input	Fuel	DMX, DMA, DMB, DMC, RMA 30, RMB 30, RMD 30, RME 180, RMF 180, RMG 380, RMH 380, RMK 380, RMH 700, RMK 700, RME (Fame), MDO 0.1% S			
			Parameter	Pitot tube factor	
			Cross-section	Circle Square Rectangle Area	
			Offset factor		
			Information		
		AL temp./humidity	AL temp. AL humidity		
Instrument	View				
	Diagnosis				
Service	Operating values				
	Switch-off	CO, NO, NO ₂ , (SO ₂)			
	Instrument data				
	Bus address				



C. Product description

This chapter provides an overview of the individual components of the product.

C.1 Scope of delivery

Designation	Article no.
Set in trolley consisting of:	0563 3500
testo 350-MARITIME flue gas analyzer fitted with: O ₂ , CO, CO ₂ (IR), NO and NO ₂ , gas preparation, built-in rechargeable battery and memory*	
testo 350-MARITIME control unit	
Connecting cable (2 m) between flue gas analyzer and control unit	
Exhaust gas probe for industrial engines, with probe pre-filter, 335 mm immersion depth incl. cone and heat protection shield, Tmax 1000°C, special hose for NO ₂ -/SO ₂ -measurement, length 2.2 m, incl. thermocouple for exhaust gas temperature measurement (NiCr-Ni, length 400 mm, Tmax 1000°C) with 2.4 m connection cable and additional temperature protection	
Mounting flange for gas sampling probe	
Robust protective case with trolley function	
Cable with battery terminals for connecting to testo 350-MARITIME	
Germanischer Lloyd (GL) certificate no. 59 488 - 08 HH DET NORSKE VERITAS (DNV)-Certificate No. A-11316	
Optional	
SO ₂ measurement	0440.3937
Exhaust gas probe for industrial engines, with probe pre-filter, 335 mm immersion depth incl. cone and heat protection shield, Tmax 1000°C, special hose for NO ₂ -/SO ₂ -measurement, length 5 m, incl. thermocouple for exhaust gas temperature measurement (NiCr-Ni, length 400 mm, Tmax 1000°C) with 5.2 m connection cable and additional temperature protection	0440 7553
Accessory	
Standard air probe (temperature and rel. humidity)	0636 9740
Connecting cable for air probe, length 1.5 m	0430 0143

C.2 Control unit

The control unit is used to control the flue gas analyzer and read out the data.

C.2.1 Overview of control unit



- ① Printer
- ② Display
- ③ Keypad
- ④ Interfaces: PC (RS232), Testo data bus (data)
- ⑤ Battery compartment (on rear)
- ⑥ Contact strips for connecting to the flue gas analyzer (on rear)
- ⑦ Magnetic holders (on rear)



Strong magnets

Damage to other devices!

- ▶ Keep well away from products which could be damaged through the effects of magnetism (e.g. monitors, computers, heart pacemakers, credit cards).



C.2.2 Keyboard

Key	Functions
	Function key (4x): Call up instrument functions or control measurement; the relevant function is shown on the display in the function bar (see <i>Display</i> , section <i>Function bar</i> , on this page)
	Switch the measuring instrument on/off.
	"Readings" view is open: Open the main menu. "Select function" or "Enter value/name" view is open: back to the "Readings" view.
	Abort selected processes or a selection or leave submenus. The main menu can always be reached by scrolling back one menu window at a time.
	Switch display light on/off or start the automatic timer.
	"Readings" view is open: Open system configuration. "Select function" or "Enter value/name" view is open: Confirm a selection/input.
	Scroll up/down, select a function, increase/reduce a value.
	Select function: The function keys may also be assigned further functions in addition to the 4 functions displayed in the function bar. If this is the case, small arrows appear above the function bar in the display.

C.2.3 Display

The display will show different content according to the view that is active at the time.

Status bar (active in all views)

The status bar displays the selected function or status information:

① neuen Messort anlegen

① Activated function

or-

② Instrument status:

Symbol	Significance
	! flashes Error present that has not yet been rectified
	Battery warning
	Measurement program is active
	Measurement program running
	rotates Searching for connected system components
	● ○ Flue gas measurement running alternating

③ Activated location



④ Device address (bus address) of the activated instrument

⑤ Displayed page/total number of pages, scroll between the pages: / .

Function bar (active in all views)

The function bar shows the function that is currently assigned to the individual function keys. The assignment of the function keys can change according to the menu.

The function keys can be configured with the following functions:

Function	Description
▲ / ▼	Scroll up/down, select a function, increase/reduce a value. Same function as for the ▲ / ▼ keys.
ESC	Abort selected processes or a selection or leave submenus. The main menu can always be reached by scrolling back one menu window at a time. Same function as for the [ESC] key.
OK	"Readings" view is open: Open system configuration. "Select function" or "Enter value/name" view is open: Confirm a selection/input. Same function as for the [OK] key.
Curr.	Accept the value currently highlighted.
Change	Edit the setting.
Test	Start a test printout.
End	Accept settings and end the function.
↔	Switch between upper-case and lower-case text.
←	Delete a character in front of the cursor.
␣	Insert a space.
Info	Display an overview of the settings.
	Reset value to the factory setting.
	Add the actual measured/calculated value as an input value.
▲ / ▼	When entering the date/time: select individual numbers.

Additional functions can be assigned individually, see *Assigning a function key*, page 36

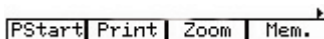

If an arrow appears above the function bar, it means that the ◀ / ▶ keys can be used to call up further functions to which a function key was assigned.

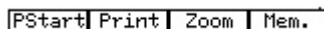

Factory setting



View: Readings

The measurement view displays the readings and the relevant parameters and units of measurement:

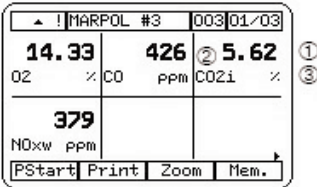

- ① Reading
- ② Parameter
- ③ Unit of measurement

6 or 3 readings are displayed on each page (this can be set using the **Zoom** function key).

View is the same as the factory setting.

View: Select function

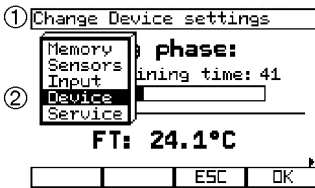

- ① Selected function
- ② Available functions; the one currently selected has a black background

View: Enter values

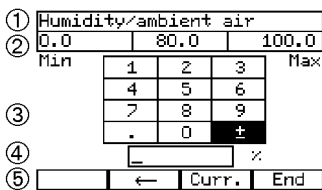

- ① Selected function
- ② Minimum/current stored/maximum value that can be entered
- ③ Input matrix for selecting the desired numbers; the selected number has a black background
- ④ Input value
- ⑤ Function bar

View: Enter name





- ① Selected function
- ② Input matrix for selecting the desired symbols (letters/numbers/special characters); the selected symbol has a black background
- ③ Display of the entered name
- ④ Function bar

C.2.4 Setting the automatic switch-off

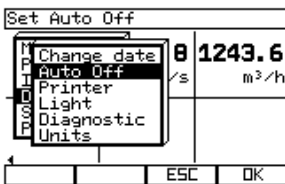
The automatic switch-off gives you the opportunity to control the control unit so that it switches itself off if the control unit is not operated within this time. The time before the switch-off procedure occurs (Auto Off time) can be chosen.



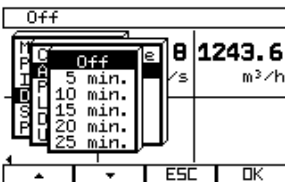

1.  → **Instrument**
2. Select the **Auto Off** menu item with  or  and press .

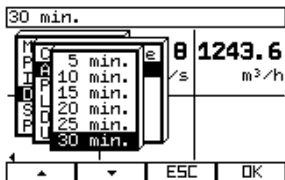

- A pull-down menu appears with the entries: **Off, 5 min, 10 min, 15 min, 20 min, 25 min, 30 min.**



3. Select the desired time for the automatic switch-off of the control unit with  or  and press .

 - The set Auto Off time is applied.

4. The selection menu can be closed with  and . The control unit is switched off automatically after the chosen time.

! If **Off** is selected, the control unit can only be switched off via .

! If a measurement program is running with a measuring cycle longer than the auto off time, the instrument goes into sleep mode after the auto off time and is reactivated for the chosen measuring cycle.

C.2.5 Changing units

Each parameter can be assigned to a unit. Various systems of units are possible:

- 1  → **Instrument** → **OK**.
- 2 **Units** → **OK**.
- 3 Select **Temperature, Humidity** or **Pressure** and confirm with **OK**

Parameter	units
Temperature	°C, °F
Humidity	Off, td°C, g/m ³ , J/g
Pressure	bar, psi, mmW, Torr, inHg, kPa

C.2.6 Showing/hiding integrated differential pressure probe

1.  → **Instrument** → **OK**.
- 2 **Configuration** → **OK**.
- 3 Select **Internal pressure sensor** and confirm with **OK**
- 4 Select **Show/hide pressure sensor** and confirm with **OK**.
- 5 Select **Scroll instruments** and confirm with **OK**
- 4 Select **Current instrument** or **All instruments** and confirm with **OK**.

C.2.7 Control unit connections/interfaces



- ① RS232: PC interface
- ② Data: Interface to system components (Testo data bus)
- ③ Additional probe input
- ④ Differential pressure

C.2.8 Control unit power supply

! Ordinary or rechargeable batteries must always be inserted in the control unit as otherwise no connection can be established with other system components and the date/time setting will be lost.

The batteries/rechargeable batteries in the control unit are only there to power the clock and establish a connection to the flue gas analyzer. The control unit cannot function if it is not connected to an flue gas analyzer. It will switch itself off after 15 s.

Power is supplied by 4 rechargeable batteries/batteries (1.5 V, mignon, type AA).

C.2.9 Air probe (temperature and humidity)

Connect the standard air probe (order no. 0636 9740) to the additional probe input ③ via the connecting cable (order no. 0430 0143).

C.3 Flue gas analyzer

The readings are taken with the help of the flue gas analyzer.

C.3.1 Flue gas analyzer overview

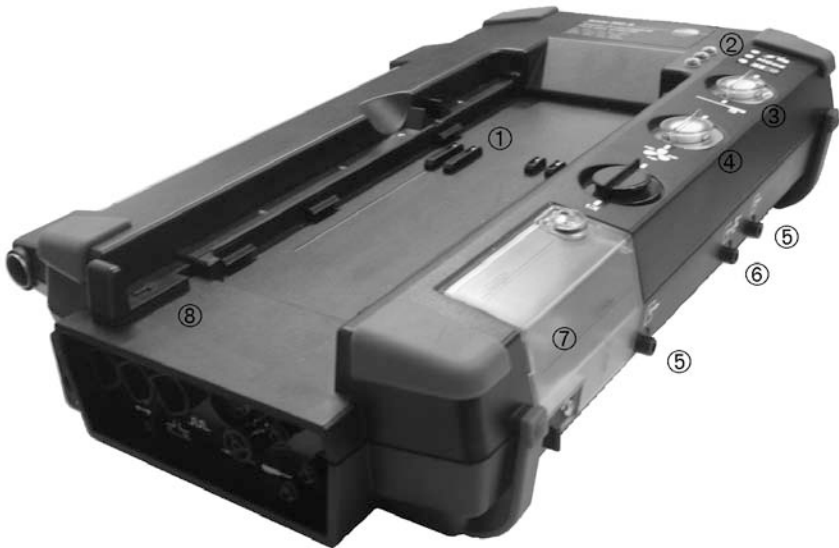

- ① Contact strips for connection to the control unit
- ② Status LEDs
- ③ Particle filter
- ④ Fresh air inlet filter (fresh air valve option)
- ⑤ Gas outlet 1+2
- ⑥ Fresh air inlet
- ⑦ Condensate container (see *Condensate container*, on page 69)
- ⑧ Unlocking lever for contact strips

C.3.2 LED status display



The status LEDs indicate the instrument status of the flue gas analyzer:

Status	Display
Power supply (LED ①):	
Mains operation	green / steady
Rechargeable battery operation (battery fully charged)	green / flashing
Rechargeable battery operation (battery low)	red / flashing
Battery recharging, instrument switched off	off
Mode (LED ②):	
Measurement	green / steady
Fresh air / zeroing	green / flashing
Error	red / flashing
Battery recharging (LED ③):	
Recharging battery (rapid charge)	green / flashing
Battery fully charged, trickle charge	green / steady

C.3.3 Flue gas analyzer connections/interfaces

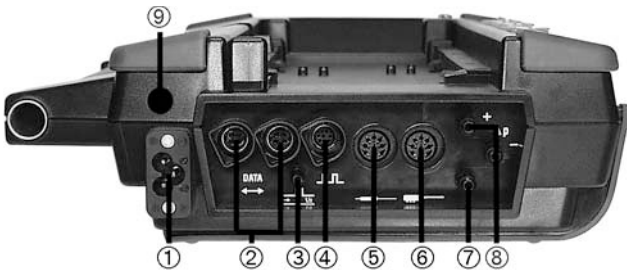

- ① Mains supply socket (110/230 V 50/60 Hz)
- ② Data: Interfaces to system components (Testo data bus)
- ③ Dilution air inlet
- ④ Trigger/alarm: interface for trigger/alarm signal
- ⑤ Ambient air temperature (AT)/temperature T2 probe connection
- ⑥ Flue gas temperature (FT)/temperature T1 probe connection
- ⑦ Flue gas input
- ⑧ Pitot tube connections
- ⑨ DC Voltage input (11 to 40 V DC)

C.3.4 Flue gas analyzer power supply

The flue gas analyzer is powered optionally by the integrated mains unit or by the testo rechargeable battery pack (0554 1098).

C.3.5 Voltage input



The flue gas analyzer can also be operated via an external voltage source (11 - 40 V DC).

The cable with battery terminals and an adapter for connecting the voltage source to the flue gas analyzer (art. no. 0554 1337) is included in the set. If the flue gas analyzer is switched off, the instrument's internal rechargeable battery can be charged via an external voltage source (11 - 40 V DC).

C.3.6 Instrument options

Only one SO₂ cell is available as an option (on request).

C.4 Flue gas probe

Avoid electrical hazards:

- ▶ Never use the measuring instrument and probes to measure on or near live parts!

Product safety/preserving warranty claims:

- ▶ Temperatures given on probes/probes relate only to the measuring range of the sensors. Do not expose handles and feed lines to any temperatures in excess of 70 °C unless they are expressly permitted for higher temperatures.
- ▶ Carry out only the maintenance and repair work that is described in the instruction manual. Follow the prescribed steps exactly. For safety reasons, use only original spare parts from Testo.

Any additional work must only be carried out by authorized personnel. Testo will otherwise refuse to accept responsibility for the proper functioning of the measuring instrument after repair and for the validity of certifications.

- ▶ The measuring instrument must not be placed on surfaces subject to extremely high vibration.
- ▶ Operate the measuring instrument in its case in accordance with its intended purpose.
- ▶ Before use: It is imperative that you observe the fitting instructions for the flue gas probe.

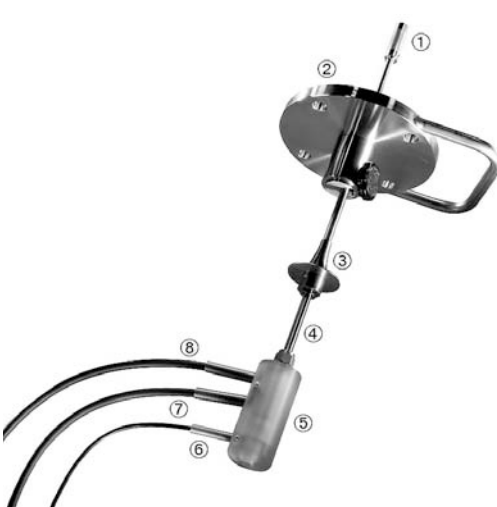

- ① Preliminary filter
- ② Cone mounting flange
- ③ Probe shaft cone
- ④ Probe shaft
- ⑤ Probe handle with connections for probe shaft and gas tubes/ Thermocouple line
- ⑥ Thermocouple
- ⑦ Gas tube
- ⑧ Positive pressure release tube



C.4.1 Positive pressure terminal

The max. positive pressure of the flue gas at the measurement gas inlet of the testo 350-MARITIME is 50 hPa (~510 mm WS).

The additional hose is used to compensate the positive pressure of 50 hPa (~510 mm WS) in the flue gas system for sampling points with positive pressure. If there is no positive pressure, the positive pressure terminal must be closed in order to prevent the intake of external air and consequently an incorrect measurement.

D. Commissioning

This chapter describes the steps required to commission the product.

Control unit

- ▶ Remove the protective film from the display.

! There must always be batteries or rechargeable batteries in the control unit as otherwise it will not be possible to establish a connection to other system components.

The control unit is supplied with a rechargeable battery pack (0554 1097) already inserted.

Flue gas analyzer:

The flue gas analyzer is supplied with a rechargeable battery pack (0554 1098) already inserted.

- ▶ Charge the rechargeable battery fully before using the flue gas analyzer (see *Charging the battery*).
- ▶ To power the flue gas analyzer, connect the integrated mains unit and the mains lead to the mains port of the flue gas analyzer or to the line to the voltage source.

! On ships where there is no stable mains voltage, the flue gas analyzer should ideally be operated with the voltage source (11 - 40 V DC) or with a suitable mains filter.

! Operation via the integrated mains unit or the DC voltage source is recommended for longer measurements.

- ▶ To guarantee the reliability of the data connection, it is recommended that the control unit and the flue gas analyzer be connected using the connecting cable (art. no. 0449 0042 included in the set).

E. Operation

This chapter describes the steps that commonly have to be carried out when configuring the flue gas analyzer or using the product.

! Please read this chapter carefully. This chapter explains the basic operating concepts of the measuring instrument. The following chapters of this document will assume you are already familiar with the contents.

E.1 Mains unit, batteries/rechargeable batteries

! If the power supply to the control unit is interrupted for a long time (e.g. batteries/rechargeable batteries low), the date/time setting will be lost.
The measuring system cannot be started if the batteries/rechargeable batteries are low.

! If the power supply to the flue gas analyzer is interrupted for a long time (low rechargeable battery pack), it will be approx. 2 h before an accurate NO_x measurement can be carried out.

E.1.1 Changing batteries/rechargeable batteries

Control unit

! The control unit must be switched off. To prevent the date/time setting from being lost, always change batteries/rechargeable batteries within 1 minute.

- 1 Open the battery compartment on the rear of the control unit (clip lock).
- 2 Remove spent batteries/rechargeable batteries and insert new batteries/rechargeable batteries (4 x mignon, type AA). **Observe the polarity!**
- 3 Close the battery compartment.

Flue gas analyzer

! The flue gas analyzer must not be connected to a mains socket or to a DC voltage supply. The flue gas analyzer must be switched off.



- 1 Open the battery compartment on the rear of the flue gas analyzer (2 clip locks, ①).
- 2 Remove the rechargeable battery pack from the battery compartment and disconnect the connector ②.

! Only use the Testo rechargeable battery pack 0554 1098). When inserting the rechargeable battery pack, make sure that the connecting cables do not get kinked or squashed.

- 3 Connect the connector of the new rechargeable battery pack in the battery compartment and insert the rechargeable battery pack into the compartment.
- 4 Close the battery compartment.

E.1.2 Charging the battery

Control unit

Charging the rechargeable batteries in the control unit takes place via the **flue gas analyzer**.

Flue gas analyzer

The rechargeable battery pack can only be charged at an ambient temperature of $\pm 10 - +25$ °C. If the battery has discharged completely, the charging time at room temperature is approx. 4-5 h.

! The flue gas analyzer must be switched off. It is not possible to charge the rechargeable battery pack during operation.

- ▶ Connect the cable with battery terminals to the flue gas analyzer or the flue gas analyzer to a mains socket.
- The charging process will start automatically. The charge status is indicated on the “Battery charging” LED:

Status	LED display
Recharging battery (rapid charge)	green/flashing
Battery fully charged, trickle charge	green/steady

- The fan of the flue gas analyzer can run during the charging process.

Rechargeable battery care

- ▶ Do not let the rechargeable battery pack discharge completely; when the battery warning symbol (⚠) lights up, charge the rechargeable battery pack as soon as possible.
- ▶ Only store the rechargeable battery charged and at low temperatures, although not below 0°C. During long periods of disuse, discharge and recharge the rechargeable battery pack every 3 - 4 months. Trickle charge for no longer than 2 days.

E.1.3 Mains operation (110/230 V, 47 - 63 Hz)

- ▶ Connect the mains cable to the flue gas analyzer and a mains socket.
- The flue gas analyzer is powered via the mains unit.
- If the flue gas analyzer is switched off and a rechargeable battery pack is inserted, the charging process will start automatically. Battery charging stops when the measuring system is switched on using the control unit.

E.1.4 Operation with DC voltage (11 V - 40 V DC)

- ▶ Connect the cable with battery terminal and adapter (art. no. 0554 337) to the flue gas analyzer and to a designated port.
- If the flue gas analyzer is switched off and a rechargeable battery pack is inserted, the charging process will start automatically. Battery charging stops when the measuring system is switched on using the control unit. It is not possible to charge the rechargeable battery pack when measuring.

E.2 Probes/sensors

E.2.1 Connecting probes/sensors

! Probe detection is carried out during the activation process: Probes that are required must always be connected before the flue gas analyzer is switched on, or the flue gas analyzer must be switched off and then on again after a change of probe, so that the correct data can be read.

- ▶ Connect the required probes/sensors to the corresponding connections.



- ▶ The flue gas temperature is measured via the thermocouple at the tip of the flue gas probe below the probe filter.

E.2.2 Positioning flue gas probe

E.2.2.1 Flue gas flow with characteristics comparable to those in the centre of the flow

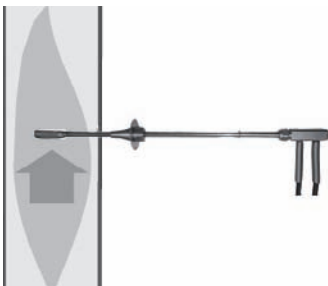

The tip of the probe must be in the centre of the flue gas flow.

- ▶ Align the flue gas probe in the flue gas duct so that the tip is in the area of the highest flue gas temperature.

! Do not take readings around the edges.
Measure at distance of min. 3x diameter of flue gas boiler from last elbow.

E.2.2.2 Flue gas flow without characteristics comparable to those in the centre of the flow

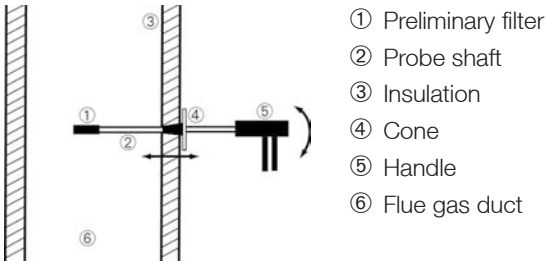

The immersion depth is dependent on the thickness of the insulation of the flue gas duct. If the flue gas is measured immediately downstream of the flue gas turbocharger, the flue gas in the flue gas duct is extremely homogenous due to the good mixing, i.e. there is no centre of flow. It is therefore not necessary to place the probe shaft in an exact position.

E.2.3 Options for securing the flue gas probe



To avoid damage to the instrument, the engine system or persons, special precautions must be taken to secure the flue gas probe if the flue gas duct is subject to strong vibration. Securing it simply by screwing in the probe cone will not hold permanently or provide a long-term tight fit if there is strong vibration.

The probe must be positioned so that no damage to the engine system can be caused by parts attached to the flue gas probe falling off or the probe fracturing.

Only leave the flue gas probe in the flue gas duct while measuring is in progress. Once measuring is finished, remove the probe from the flue gas duct.

If the end of the probe is hanging freely, it must be fixed/supported with an appropriate mechanism in addition to the probe fixture. Otherwise there is a risk that the probe will fracture.

E.2.3.1 Mounting flange

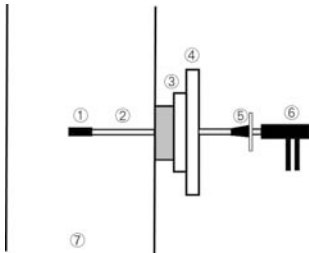

- ① Preliminary filter
- ② Probe shaft
- ③ Secured assembly component
- ④ Mounting flange
- ⑤ Cone
- ⑥ Handle
- ⑦ Flue gas duct

E.2.3.2 Using a mounting flange

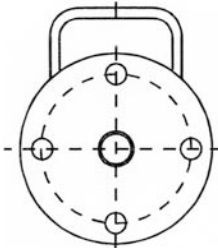

The mounting flange is used to secure the flue gas probes on the assembly component.

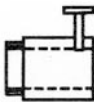

A feed-through socket is used to position the probe shaft and to allow infinitely variable adjustment of the length; this socket is screwed into the flange. The locating screw fixes and secures the sampling probe.



A reduction clamping sleeve is used to position the sampling probe and to allow infinitely variable adjustment of the length; this sleeve is inserted into the feed-through socket.

- ▶ Secure mounting flange to assembly component.
- ▶ Screw feed-through socket into the mounting flange.
- ▶ Tighten fixing screw of feed-through socket.

E.2.3.3 Using a cone

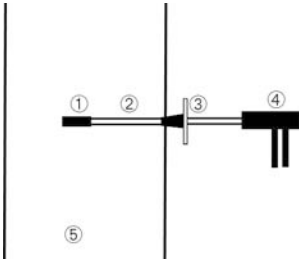

- ① Preliminary filter
- ② Probe shaft
- ③ Cone
- ④ Handle
- ⑤ Flue gas duct

- ▶ Align the flue gas probe in the flue gas duct so that the tip is in the area of the highest flue gas temperature.
- ▶ Tighten cone firmly.

E.2.3.4 Use welded-on shaft

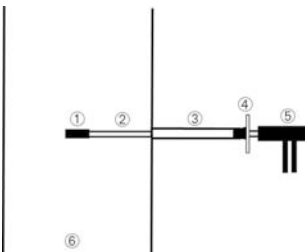

- ① Preliminary filter
- ② Probe shaft
- ③ Welded-on shaft
- ④ Cone
- ⑤ Handle
- ⑥ Flue gas duct

- ▶ Align the flue gas probe in the flue gas duct.
- ▶ Tighten cone firmly.

E.2.4 Vibrations

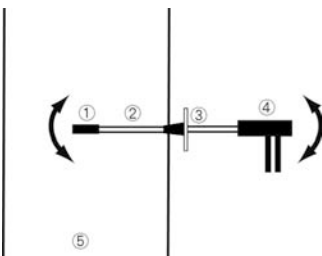

- ① Preliminary filter
- ② Probe shaft
- ③ Cone
- ④ Handle
- ⑤ Flue gas duct

- ▶ Secure cone in the sampling point and seal
- ▶ Ensure that no attached parts can fall into the flue gas shaft.
- ▶ If the end of the probe is hanging freely, stabilize the probe with appropriate means.

E.3 Basic operating steps

E.3.1 Connecting the control unit to the flue gas analyzer

! Only one flue gas analyzer can be connected to the control unit.

Connection using contact strips



- 1 Place the control unit on the flue gas analyzer so that the guide nose on the left side of the control unit (①) is above the guide groove of the flue gas analyzer (②).
- 2 Press the control unit against the flue gas analyzer until you hear it engage.

Connection using a data bus cable (included in the set)

- ! Only use Testo data bus cables.
- ! Do not lay data bus cables near power cables.
 - ▶ Connect the data bus cable to the “Data” ports of the control unit and flue gas analyzer.

E.3.2 Switching on the flue gas analyzer

- ! Before switching the flue gas analyzer on, check that:
- The control unit is correctly connected to the flue gas analyzer.
 - All the necessary probes/sensors are connected.
 - The power supply of all system components is guaranteed.

Measuring the ambient air temperature (AT)

If no ambient air temperature sensor is connected, the temperature measured by the thermocouple of the flue gas probe during the zeroing phase is used as the ambient air temperature. All dependent parameters are calculated using this value. This method of measuring ambient air temperature is sufficient for systems dependent on ambient air. The fresh air required for the zeroing phase is drawn in through the fresh air inlet. The flue gas probe may therefore already be in the flue gas duct before or during the zeroing phase.

During the zeroing phase, the measuring instrument verifies the zero point and the drift of the gas sensors. The O₂ sensor is also set to 21 % O₂.

If an ambient air temperature sensor is connected, the ambient air temperature is measured continuously via this sensor.





The flue gas probe may already be in the flue gas duct during the zeroing phase.

Zeroing phase

During the zeroing phase

- the measuring cells of the flue gas analyzer are zeroed.
- no interfering gases (e.g. CO, NO) may be present in the ambient air!

Switching on:

1. Press .
- The initialization screen is displayed and the data bus is scanned for connected system components (this takes up to 60 s).
- The zeroing phase starts (this takes 60 s).
- Measurement view is opened.
2. Access the selection window using the  key.
3. Choose between the control unit and flue gas analyzer using the ,  arrow keys.
4. Confirm with  key.

Switching off:

1. Press .



E.3.3 Calling up a function

Functions can be called up using function keys or from a selection list.

Calling up a function using a function key

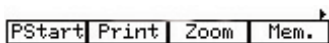
Only particular functions can be called up using a function key, see *Display*, section *Function bar*, page 17.







If an arrow appears above the function bar, it means that the  /  keys can be used to call up further functions to which a function key was assigned.

- ▶ Press the function key that is assigned the desired function.







Calling up a function using a selection list

Selection lists appear e.g. when the main menu is called up (press  in measurement view).

- 1 Select function:  or press .
- The selected function is shown with a black background.
- 2 Confirm selection: Press .
- The chosen function is opened.

E.3.4 Assigning a function key

The function keys that are shown on the display depend on the view that is selected. Only the function keys that can be used in the particular view are displayed.

- The measurement view is opened.
- 1 Press , release and immediately afterwards press the function key to be assigned.
 - A selection list showing the functions that can be assigned to a function key appears.
 - 2 Select the function with  or  and confirm with .

Function	Description
PStart, PStop	Start the measuring gas pump and display readings or stop the measuring gas pump (the function key switches between the two options automatically)
Zoom	Zoom in (display 6 or 3 readings per page)
v On, v Off	Zero the pressure sensor and activate flow measurement or switch off flow measurement (the function key switches between the two options automatically)
Save	Save readings
Start, Stop	Start or stop the measurement program (the function key switches between the two options automatically)
Print	Print readings
LF Pr	Activate the printer line feed
Zero	Start the zeroing phase manually (duration: 60 s)
Diag.	Display unrectified errors
dP	Activates the separate differential pressure measurement in the flue gas analyzer.
Gas (air)	Manual change from measuring gas to ambient air.
CO off	Manual disconnection and rinse with fresh air.
CO on	Manual connection of a deactivated CO sensor to the gas path.
(empty)	The function key does not trigger any function

E.3.5 Air humidity/temperature of engine intake air

The ambient humidity and temperature of the intake air of the turbocharger must be factored in to ensure that the flue gas values are calculated correctly in accordance with NOx-TC and MEPC.103(49).

The following values are stored as factory settings:

- Ambient humidity: 80% RH.
- Ambient temperature 20 °C

In order to factor the respective current ambient conditions into the measurement, it is recommended that the air probe (temperature and rel. humidity) with order no. 0636 9740 be connected to the control unit via the connecting cable (length 1.5 m) with order no. 0430 0143.

If the respective current ambient conditions are already known without using the Testo air probe, the factory settings can be overwritten with the current values using the input editor.





E.3.5.1 Accepting the current reading

The data of the air probe is recorded once when the gas sensors are zeroed and then used permanently for this series of measurements. The current values of the air probe are thus adopted each time the instrument is zeroed again.

Some functions require values (figures) or a name (characters) to be entered. Inputs are made using an input editor.

Input editor for values

Humidity/ambient air		
0.0	80.0	100.0
Min		Max
1	2	3
4	5	6
7	8	9
.	0	±
_ ×		
←	Curr.	End

1 Select the value (character): Press , , , .

2 Accept the value: Press .

Options:

Accept current reading from connected air probe (art. no. 0636 9740): .

Delete a character in front of the cursor: .

Accept the value currently highlighted: .

Select individual number (only when inputting date/time): , .

3 Repeat steps 1 and 2 as required.

4 Accept settings: Press .



Input editor for names



1 Select the value (character): Press **←**, **→**, **↑**, **↓**.

2 Accept the value: Press **OK**.

Options:

Switch between upper-case and lower-case letters: **a↔fl**.

Delete a character in front of the cursor: **←**.

Insert space: **↵**.

3 Repeat steps 1 and 2 as required.

4 Accept settings: Press **End**.

E.3.6 Printing data

To print readings, a function key must be assigned the **Print** (Print readings) function, see *Assigning a function key*, page 36.

Only those readings that were assigned a display field in the Measurement view will be printed.

E.3.6.1 Printing the current readings

► To print readings: **Print**.

The measurement data that are currently stored can be printed out while a measurement program is running.







1 Open the Main menu: Press **☰**.

2 **Memory** → **OK** → **Read out** → **OK**.

3 Select the protocol for the current measurement and confirm with **OK**.

4 Print readings: **Print**.

E.3.6.2 Printing stored readings

- 1 Open the Main menu: Press .
- 2 **Memory** →  → **Read out** → .
- 3 Select the measurement protocol with   and confirm with .
- 4 Press  function key.

The readings are printed column by column.

E.3.7 Saving data

To save readings, a function key must be assigned the **Save** (Save readings) function, see *Assigning a function key*, page 36.

Only those readings that were assigned a display field in the Measurement view will be saved.

- ▶ To save readings: .

E.3.8 Switching off the flue gas analyzer

! Unsaved readings are lost when the flue gas analyzer is switched off!

! Rinse phase

During the rinse phase the gas sensors of the flue gas analyzer are rinsed with fresh air. The duration of the rinse phase depends on the gas concentration in the measuring cells. The rinse phase is ended once a certain threshold value is reached.





Switching off:

- ▶ Press .
- The rinse phase starts.
- The measuring system switches itself off. It is normal for the fan of the flue gas analyzer to run on for a while.
- If the flue gas analyzer is connected to a mains socket and a rechargeable battery pack is inserted, the charging process will start automatically.









E.4 Setting the measuring system up

E.4.1 Setting the language

- The measurement view is opened.
- 1 Open the Main menu: Press .
- 2 **Service** →  → **Sprache** or **Lang.** → .
- 3 Select the language and confirm with .

E.4.2 Setting the date/time

- The measurement view is opened.
- No measurement program is active (otherwise the function is locked).
- 1 Open the Main menu: Press .
- 2 **Instrument** →  → **Change date** → .
- 3 Select the date or time with ,  and press .
- The input editor is opened.
- 4 Enter values and accept settings with .

E.4.3 Setting the fuel

- The measurement view is opened.

1 Open the Main menu: Press .

2 **Input** → **OK** → **Fuel** → **OK**.

The following fuels can be selected in the flue gas analyzer:

Fuel	Description
Distillate fuel oil (DM)	DMX
	DMA
	DMB
	DMC
Residual fuel oil (RM, RFO)	RMA 30
	RMB 30
	RMD 80
	RME 180
	RMF180
	RMG 380
	RMH 380
	RMK380
	RMH 700
	RMK 700
Rapeseed Oil Methyl Ester (RME)	RME (FAME)
Test gas	Test gas
User-defined 1	Fuel 1
User-defined 2	Fuel 2
Low-sulphur diesel (0.1% sulphur)	MDO 0.1% S

3 Select the fuel and confirm with **OK**.

E.4.3.1 Select user-defined fuel

- The measurement view is opened.

1 Open the Main menu: Press .

2 **Input** → **OK** → **Fuel** → **OK**.

3 Select **Fuel1/Fuel2** with ,  → **OK**

- Coefficient information window for **fuel1/fuel2**

- **H content** (hydrogen content), factory setting 13.6%

- **C content** (carbon content), factory setting 86.2%

- **S content** (sulphur content), factory setting 1.5% are displayed

4 Select hydrogen content, carbon content or sulphur content with , confirm with **OK**.

- The input editor is opened.



5 Enter the values

- **H content** adjustment range: 0.1...99.9%
- **C content** adjustment range: 0.1...99.9%
- **S content** adjustment range: 0.0...5.0%

6 Accept settings with .

E.4.4 Changing the display sequence

Only those parameters and units of measurement to which a display field was assigned in the measurement view are displayed in the measurement view, in the saved measurement protocols and on printouts of readings.

The assignment of parameters/units of measurement to the individual display fields in the Measurement view can be changed. The following parameters and units are available (may vary from one instrument to another):

Display	Parameter	Units
O2	Oxygen	%
CO	Carbon monoxide	ppm, %
NO	Nitrogen monoxide	ppm, %
SO2	Sulphur dioxide	ppm, %
NO2	Nitrogen dioxide	ppm, %
H2	Hydrogen	ppm
NOx (addition of NO and NO2)	Nitrogen oxides	ppm, %
FT	Flue gas temperature	°C, °F
AT	Ambient air temperature	°C, °F
CO2i	Carbon dioxide	%
dP	Differential pressure	mbar, hPa, mmWS, inW
Rech. batt.	Rechargeable battery voltage	V
	Flue gas analyzer	

Display	Parameter	Units
Itemp	Instrument temperature	°C, °F
B/h	Operating hours	h
Pump	Pump output	l/m
Speed	Flow speed	m/s
Fuel	Fuel	-
NOxt	NOx display value corrected for CLD (chemiluminescence) This display value is based on dry flue gas.	ppm %
NOxn	NOx display value corrected for CLD (chemiluminescence) This display value is based on wet flue gas.	ppm %
SO2n	Based on wet flue gas	ppm %
H2Ob	Calculated moisture content of fuel	%
Pabs	Absolute pressure	hPa

- The measurement view is opened.

1 Open the Main menu: Press .

2 **Instrument** → → **View** → .

- The parameter and the unit of the display fields is displayed.

3 Select the display field to be changed with , , , and confirm with .

Options:

▶ Insert a new display field: **Insert** → .

▶ Delete the current display field: **Delete** → .

4 Select **Parameter** and confirm with .

- 5 Select the parameter that is to be assigned to the display field and confirm with **OK**.
- 6 Select the unit of measurement that is to be assigned to the parameter and confirm with **OK**.

E.4.5 Setting up locations

The memory in the testo 350-MARITIME is organized in such a way that what is known as a “location” must be activated to identify a saved measurement. The default location is called **Noname**.

On saving, readings are assigned to whichever location is active at the time of saving. Several measurements can be saved for each location. It is also possible to organize locations in folders/subfolders.

The maximum possible number of measurements that can be saved depends on whether each individual measurement is saved under its own location or all measurements are stored exclusively under one location.

! The saved messages are stored consecutively with the respective date and time and can therefore be selected easily.

Unsaved readings are lost when the measuring instrument is switched off!

Creating/copying/editing/deleting folder/location:

- The measurement view is opened.
- 1 Open location management: **OK** and press **◀**.
 - Available folders (📁) and locations (📍) are displayed.
 - ▶ If the folder/location is to be created in an existing folder: Select the folder and confirm with **OK**.
 - ▶ If a folder/location is to be edited, deleted or copied: Select the folder so that it is given a colour background.
 - 2 Press **Edit**.

Options:

- ▶ To print saved measurement data records of the selected location:
Print location → **OK**.
 - ▶ To display information about the selected location: **Info** → **OK**.
- 3 Select the desired option and confirm with **OK**.
 - 4 When creating, copying or editing a folder/location: Enter the name and confirm with **End**.

Activating a location:

- The measurement view is opened.
- 1 Open location management: **OK** and press **◀**.
- Available folders (**📁**) and locations (**📍**) are displayed.
- 2 Select the desired folder or location and confirm with **OK**.
 - ▶ If a folder was selected: Repeat the process.
- Measurement view is opened.

E.4.6 Changing the instrument name

- The measurement view is opened.
- 1 Open location management: Press **OK**.
- 2 Press **▶**.
- The connected instruments are displayed.
- 3 Select the instrument and press **Edit**.
- 4 Enter the name and confirm with **End**.

E.4.7 Set up printer

The control unit must be switched off.

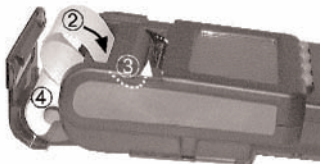

- 1 Open the printer paper compartment: Hold the cover by the recesses on the sides and pull upwards (①).
- 2 Push the start of the paper roll as far as possible into the infeed with the outside (= printable side) facing down (②).
- 3 Switch on the control unit Press **⏻**.
- 4 Press **LfDr** 12 or 13 times during the initialization phase to draw the paper in (③). The paper may have to be pushed in gently by hand until the forwarder roller picks it up.
- 5 Place the paper roll into the paper compartment (④) and close the paper compartment.

F. Main menu

This chapter describes the functions that are available in the main menu of the control unit and the flue gas analyzer.

! Familiarity with the contents of the chapter *E. Operation* (see page 27) is assumed.

F.1 Control unit

F.1.1 Probes

F.1.1.1 Damping

If the readings fluctuate widely, it is advisable to damp the readings.

1.  → **Probe** → **OK**.
2. **Damping** → **OK**.
3. Select **Internal sensor** or **Probe socket 1** and confirm with **OK**.
4. Select **Values** and confirm with **OK**.
5. When selecting values: Enter the value and confirm with .

Example:

n = min. 2 - max. 10: Running average over up to 10 measurement cycles.

n value = 5: Running average over 5 measurement cycles.

F.1.1.2 Surface addition

Surface probes withdraw heat from the measured surface immediately after the initial contact. This makes the measurement result lower than the true surface temperature without the probe (or the reverse if the surface is colder than the environment). This effect can be corrected by an increment in % of the reading.

All temperature probes are corrected by the entered value regardless of the selected location.

1.  → **Probe** → **OK**.
2. **Surface addition** → **OK**.
3. Enter the value and confirm with .

F.1.1.3 Temp. probe adjustment

Temperature probes with EEPROM can be adjusted to a reference temperature, e.g. using a calibration bath. The reference temperature is preferably present at the working point of the temperature probe. Following the adjustment, the temperature readings from this probe are then correspondingly altered, e.g. an offset correction takes place. An adjustment is only possible with an EEPROM temperature probe connected to the control unit.

1.  → **Probe** → **OK**.
2. **Point** → **OK**.
3. Enter the value and confirm with

F.1.1.4 Hum. probe adjustment

The 0636.9740 air probe is adjusted via the control unit (Control and adjustment set for humidity sensors 0554 0660).

1.  → **Probe** → **OK**.
2. **Calibr.** → **OK**.
3. Perform adjustment.

 No reset can be carried out for the humidity adjustment.

F.1.1.5 Scaling

Scaling can be performed for the current/voltage cable (order no. 0554.0007).

1.  → **Probe** → **OK**.
2. **Scaling** → **OK**.
3. Perform scaling.

F.1.1.6 Reset

Internal sensor, **Probe socket 1** and/or **All probes** can be reset to the factory setting.

The following is reset:

- the set damping
- the surface addition
- the adjustment
- and the scaling

1.  → **Probe** → **OK**.
2. **Reset** → **OK**.
3. Select **Internal sensor, Probe socket 1** or **All probes** and confirm with **OK**.

F.1.1.7 Info

Information about adjusted probes.

1.  → **Probe** → **OK**.
2. **Info** → **OK**.
3. Select **Internal sensor, Probe socket 1** and confirm with **OK**.

F.1.2 Instrument

F.1.2.1 Change date

Setting the date/time

- No measurement program is active (otherwise the function is locked).



1.  → **Instrument** → **OK**.
2. **Change date** → **OK**.
3. Select the date or time → .
4. Enter the values → .

F.1.2.2 Auto off

see Chapter C.2.4 Switch-off, page 19

F.1.2.3 Printer

Setting the contrast

1.  → **Instrument** → **OK**.
 2. **Printer** → **OK**.
 3. **Contrast** → **OK**.
 4. Set the contrast with , .
- Option:
- ▶ Start a test printout: .
 5. .



Entering header/footer text

To document the assigned company and the assigned employee, it is possible to enter printed texts: Three lines and one footer can be filled variably with numbers and letters.

- 1 → **Instrument** → **OK**.
- 2 **Printer** → **OK**.
- 3 **Print text** → **OK**.
- 4 Select the line → **OK**.
- 5 Enter the text → .

F.1.2.4 Light

Switching the display light on/off.

On/off

The display light is switched on/off via . After switching on, the display light must be activated by pressing the key.

Automatic

The display light is switched on when the control unit is switched on. The display light is switched off automatically after 3 minutes. By pressing , the display light remains on for an additional 3 minutes.

- 1 → **Instrument** → **OK**.
- 2 **Lighting** → **OK**.
- 3 Select **On/Off** or **Automatic** and confirm with **OK**.

! The lighting reduces the running time of the control unit in battery operation. Use the lighting only when needed.

F.1.2.5 Diagnosis

In the event of problems and malfunctions, the fault description and possible remedial measures are described

- 1 → **Instrument** → **OK**.
- 2 **Diagnosis** → **OK**.

1.2.6 Units

see Chapter C2.5 Changing units, page 20

F.1.2.7 Configuration

see Chapter C2.6 Showing/hiding integrated differential pressure probe, page 20

F.1.3 Service

F.1.3.1 Operating values

Displaying operating values:

- 1  → **Service** → **OK**.
- 2 **Operating values** → **OK**.

F.1.3.2 Reset Factory

Displaying operating values:

- 1  → **Service** → **OK**.
- 2 **Reset Factory** → **OK**.
- 3 **Yes** or **No** and confirm with **OK**.
- 4 If **Yes** is selected: The values are reset to the factory setting.

F.1.3.3 Address

Displaying the Testo service address:

- 1  → **Service** → **OK**.
- 2 **Address** → **OK**.

F.1.3.4 Instrument data

Displaying instrument data:

- 1  → **Service** → **OK**.
- 2 **Instrument data** → **OK**.

F.1.3.5 Language

Setting the menu language:

- 1  → **Service** → **OK**.
- 2 **Sprache** or **Lang.** → **OK**.
- 3 Select the language → **OK**.



F.2 Flue gas analyzer

F.2.1 Memory

F.2.1.1 Reading out

Viewing/printing saved measurement data:

1  → **Memory** → **OK**.

2 **Read out** → **OK**.

3 Select the measurement data record.

Option:

▶ View the properties of the measurement data record: , return with .

4 Confirm with **OK**.

Option:

▶ Print a measurement data record: .

F.2.1.2 Program

Instrument settings cannot be changed if a program is active or running.

Saving (= activating) a measurement program:

1  → **Memory** → **OK**.

2 **Program** → **OK**.

3 Select the measurement program and confirm with **OK**.

4 Select **Save** and confirm with **OK**.

- The measurement program is activated.

Deleting (= deactivating) a measurement program:

1  → **Memory** → **OK**.

2 **Program** → **OK**.

3 Select the measurement program and confirm with **OK**.

4 **Delete** → **OK**.

- The measurement program is deactivated (not deleted!).

View the properties of the measurement program:

- 1  → **Memory** → **OK**.
- 2 **Program** → **OK**.
- 3 Select the measurement program.
- 4 Press **Information**
- or -
OK → **Info** → **OK**.
- The properties of the selected measurement program are displayed.
- 5 To leave the function without activating a program: **ESC**.
To leave the function and activate a program: **OK**.

Editing a measurement program:

- 1  → **Memory** → **OK**.
- 2 **Program** → **OK**.
- 3 Select the measurement program and confirm with **OK**.
- 4 Select the first parameter for defining the measurement program and confirm with **OK**.
- 5 Enter the properties/values and confirm.
- 6 Repeat the process for other parameters.

Long-term measurement of flue gas

Programming the instrument

 No settings can be made on the instrument while the program is active.

Enter values according to the measurement task:

- 1 **Memory** → **Program** → **Start** → **OK**

Start criteria:

- **Manual:**
By pressing the **Start** function key in the measurement menu.
 - **Date/time:**
Beginning of measurement at the selected date/selected time
- 2 Enter the start criterion.



3 Confirm with **OK**.

- Program jumps automatically to the mean calculation:
- With Mean **Yes**, only the mean values are stored:
The measuring rate is the storage cycle of the mean values.
- Mean of mean values:
The instrument stores a mean value of all the mean values. Once the measurement data have been retrieved from the memory, this mean value is marked with *.

4 Enter the measuring rate.

- Program jumps automatically to the selection of the end criterion:

Memory full
Number of values
Date/Time

5 Enter the values and confirm with **End**.

- Program jumps automatically to the selection of the gas time cycle (= flue gas measurement).

6 Enter the gas time and confirm.

! The pump is stopped when a threshold concentration is reached (e.g. $O_2 > 20.5\%$).
Reason: low wear and power consumption.

- Program jumps automatically to the selection of the rinse time cycle:

7 Enter the rinse time and confirm.

- An overview of a programmed long-term measurement appears.

8 Confirm measurement program with **OK**.

- Measurement program is accepted and configured:

9 Press the **Start** function key.

- Long-term measurement begins:
⚡ symbol indicates that a program is running.

The long-term measurement starts with the fresh air/rinse phase:

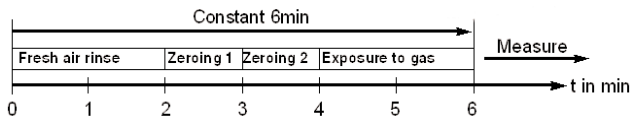

Fresh air time between measuring cycles:

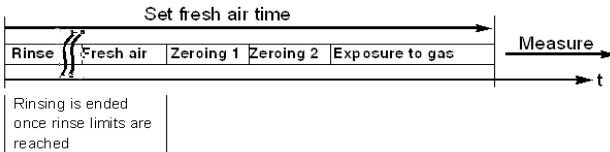

Minimum and maximum measuring and fresh air cycles:

Measuring cycles: 2 min ... 240 min (4 h)

Fresh air cycles: 5 min ... 1,440 min (24 h)

10 Stop the programmed measurement early with **Stop**.

- The measurement program stays activated (indicated by the symbol).
- At the end of the measurement program there is a rinse phase of 2 min (pump runs on).

Restarting the measurement program

- ▶ Press the **Start** function key.
- The measurement program starts again.

Deleting the instrument's programming

1 Select **Memory** → **Program** → → **Delete**.

The measurement program is only deactivated and not deleted.

2 Select **Memory** → **Program** → **Info**.

- The measurement program that was last set will be displayed.

3 Reactivate by pressing the function key.

F.2.1.3 Delete memory

Deleting the entire memory (folders, locations and measurement data):

1 → **Memory** → .

2 **Delete memory** → .

3 **No** → : Cancel the function.

- or -

Yes → : Clear the memory.

F.2.1.4 Free memory

Viewing free memory space:

1 → **Memory** → .

2 **Free memory-** → .



F.2.2 Sensors

F.2.2.1 Calibration/readjustment

CO, SO₂, NO₂, NO and O₂ sensors can be tested (calibrated) and readjusted; the CO₂(IR) sensor can be readjusted. A readjustment of O₂ only lasts until zeroing is performed. Calibration data are stored in the sensor, not in the instrument! The relevant calibration specifications in the applicable standards/guidelines must be observed.

If readings displayed are obviously unrealistic, the measuring cells should be checked and readjusted as required. To ensure that specific accuracies are retained, Testo recommends testing every six months and readjustment when required.



Warnung!

Dangerous gases

Danger of poisoning!

- ▶ Observe safety regulations/accident prevention regulations when handling test gases.
- ▶ Use test gases in well ventilated rooms only.
- ▶ Before calibrating/readjusting, select the fuel “test gas” (see Setting the fuels, page 41)

Once the calibration/readjustment has been successfully completed, it is essential that the fuel from the application is reset in order to avoid incorrect measurement results.

Recommended test gas concentrations

In order to achieve the maximum sensor accuracy possible, the following test gas concentrations and test gas compositions are recommended:

Parameter	Meas. range
CO	500 ppm (in N ₂)
CO ₂	10% (in N ₂)
NO	1000 ppm (in N ₂)
NO ₂	100 ppm (in synthetic air)
SO ₂	1,000 ppm (in N ₂) (maximum)

! Readjustment with low gas concentrations can lead to deviations in accuracy in the upper measuring ranges. Sensor protection (**Switch-off** function) is not deactivated in readjustment. The test gas concentration should therefore be lower than the set thresholds for the sensor protection.

The following conditions must be met when readjusting:

- Use absorption-free tube material
- Switch the measuring instrument on at least 20 min before readjustment (warming-up)
- Use clean air for gas zeroing
- Maximum overpressure of the test gas: 30 hPa (recommended: unpressurized via bypass)
- Charge the test gas for at least 3 min

The **Recal.** function can be protected by means of a password. The password may be customized, see *Parameter*.

Performing CO₂(IR) readjustment:

A zeropoint calibration must be performed before CO₂(IR) is readjusted. Gradient adjustment (2nd calibration point) can be carried out subsequently if necessary.

The zeropoint calibration requires a test gas of 0% CO₂ or a CO₂ filter (absorption filter). If using a CO₂ filter, please follow the corresponding instructions for use.

! At ambient temperatures of <10 °C, the warm-up time required by the CO₂ IR sensor to reach full measuring accuracy is short. At -5 °C, it is typically 15 min.

Checking the CO₂ module

Check the CO₂ module at regular intervals using the absorption filter in order to obtain accurate readings.

The instructions for use enclosed with the CO₂ filter set out how the filter should be handled.

The CO₂ value displayed should be < 0.3% CO₂. If the value is any higher than this, a zeropoint calibration and where necessary a gradient calibration must be performed.

1  → **Sensors** → .

2 **Recal.** → .

3 If password protection is activated: Enter the password → .

4 **CO₂i** → .

5 Connect the CO₂ filter or apply test gas (0% CO) and confirm with .

- A rinse phase is started.

6 When the rinse phase is over start zero point calibration with .

- Once a stable actual value is reached, the zero point is automatically calibrated.

7 Repeat zero point calibration: **Zeropoint calibration** → .

- or -

End the function: .



56 F. Main menu
F.2 Flue gas analyzer

- or -

Perform gradient calibration: **Gradient** → **OK**.

8 Enter the test gas concentration (nominal value) → **Start**.

9 Start gradient adjustment with **Start**.

- Once a stable actual value is reached, the gradient is automatically calibrated.

A test gas check can be carried out to check the readjustment:

10 End the function without carrying out a check: **ESC**

- or -

Carry out a check: **OK**.

11 Enter the test gas concentration (nominal value) (or a different concentration as in recalibration) → **Start**.

- Once a stable actual value is reached, the result of the test gas check is displayed.

12 Save the nominal value/actual value and date/time of the test without adjusting the sensor and end the function: **Save**.

Calibrating/readjusting CO/NO2/NO/O2 sensors:

1  → **Sensors** → **OK**.

2 **Recal.** → **OK**.

3 If password protection is activated: Enter the password → **End**.

4 Select the sensor → **OK**.

5 Enter the test gas concentration (nominal value) → **End**.

6 Charge the sensor with test gas and wait until the actual value is stable.

7 Save the nominal value/actual value and date/time of the test without adjusting the sensor and end the function: **Save**.

-or-

Adjust sensor: **OK**.

A test gas check can be carried out to check the readjustment:

8 End the function without carrying out a check: **ESC**

- or -

Carry out a check: **OK**.

9 Enter the test gas concentration (nominal value) (or a different concentration as in recalibration) → **End**.

10 Charge the sensor with test gas and wait until the actual value is stable.

11 Save the nominal value/actual value and date/time of the test without adjusting the sensor and end the function: **Save**.

Calibrating/readjusting SO₂ sensor

! While carrying out steps 6 to 10, the measuring instrument must **continuously** be connected to test gas!

1  → **Sensors** → **OK**.

2 **Recal.** → **OK**.

3 If password protection is activated: Enter the password → **End**.

4 Select the sensor → **OK**.

5 Enter the test gas concentration (nominal value) → **Ende**.

6 Charge the **SO₂** sensor with test gas and wait until the actual value is stable.

7 Save the nominal value/actual value and date/time of the test without adjusting the sensor and end the function: **Save**

-or-

Adjust SO₂ sensor: **OK**.

8 Continue test gas connection until the actual value is stable.

9 Save the nominal value/actual value and date/time of the test without adjusting the sensor and end the function: **Save**.

-or-

End adjustment of SO₂ sensor: **OK**.

A test gas check can be carried out to check the readjustment.

10 End the function without carrying out a check: **ESC**

- or -

Carry out a check: **OK**.

11 Enter the test gas concentration (nominal value) (or a different concentration as in recalibration) → **End**.

12 Charge the sensor with test gas and wait until the actual value is stable.

13 Save the nominal value/actual value and date/time of the test without adjusting the sensor and end the function: **Save**.



F.2.2.2 Printing sensor data

Printing saved sensor data:

- 1  → **Sensors** → **OK**.
- 2 **Print sensor data** → **OK**.

F.2.2.3 Sensor status

Display the adjustment date, sensitivity of the sensors and filter life (in ppmh):

- 1  → **Sensors** → **OK**.
- 2 **Sensor status** → **OK**.

- CO and NO filter life is displayed and can be printed out.

Example calculation for 350 ppm SO₂ and 600 ppm NO_x and
4 h measurement/day

CO sensor

$600 \text{ ppm NO}_x + 350 \text{ ppm SO}_2 \times 4 \text{ h/day} = 3,800 \text{ ppmh/day}$
 $275,000 \text{ ppmh} / 3,800 \text{ ppmh/day} = 72 \text{ days}$

NO sensor

$350 \text{ ppm SO}_2 \times 4 \text{ h/day} = 1,400 \text{ ppmh/day}$
 $70,000 \text{ ppmh} / 1,400 \text{ ppmh/day} = 50 \text{ days}$

! As soon as the sensitivity of a sensor falls below a certain threshold (<50 %),
the sensor should be replaced.

F.2.3 Input

F.2.3.1 Fuel

Selecting fuel:

- 1  → **Input** → **OK**.
- 2 **Fuel** → **OK**.
- 3 Select the fuel → **OK**.





F.2.3.2 Parameter

Entering calculation parameters:





Some calculated variables relate to particular reference values (ambient conditions or factors for certain probes). These can be entered by means of the parameter function.

The following values can be entered for the individual parameters:







Parameters	Value input
Pressure	from altitude: Enter the barometric pressure, metres above sea level and differential pressure absolute: Enter the absolute pressure directly or have the absolute pressure calculated from the values of the barometric pressure, metres above sea level and differential pressure parameters with 
Pitot tube factor	This value depends on the type of Pitot tube that is used
Cross-section	Circle: Enter the diameter of the circle Square: Enter the side length Rectangle: Enter the side lengths a and b Area: Enter the cross-section area
Correction factor	This should be set at 1.00 for all standard applications

- 1  → Input → .
- 2 Parameter → .
- 3 Select the parameter → .
- 4 Enter the value(s) → .

Viewing the settings of the calculation parameters:

- 1  → Input → .
- 2 Parameter → .
- 3 Info → .

F.2.3.3 AL temp./humidity

- 1  → Input → .
- 2 AL temp./humidity → .
- 3 AL temp → .
- 4 Enter the value(s) → .
- 3 AL humidity → .
- 4 Enter the value(s) → .



F.2.4. Instrument

F.2.4.1. View

The assignment of parameters/units of measurement to the individual display fields in the measurement view can be changed, see *Changing the display sequence*, see page 42.

F.2.4.2 Diagnostic

In the event of problems and malfunctions, the fault description and possible remedial measures are described

- 1  → **Instrument** → **OK**.
- 2 **Diagnosis** → **OK**.

F.2.5 Service

F.2.5.1 Operating values

Displaying operating values:

- 1  → **Service** → **OK**.
- 2 **Operating values** → **OK**.

F.2.5.2 Switch-off

Threshold values can be set in order to protect the sensors against overloading. If these values are exceeded, the sensors are switched off automatically.

The switch-off function can be protected by means of a password. The password may be customized.

Setting switch-off thresholds:

- 1  → **Service** → **OK**.
- 2 **Switch-off** → **OK**.
- 3 If password protection is activated: Enter the password → .
- 4 Select the sensor → **OK**.
- 5 Enter the threshold value → .

F.2.5.3 Address

Displaying the Testo service address:

- 1  → **Service** → **OK**.
- 2 **Address** → **OK**.

F.2.5.4 Instrument data

Displaying instrument data:

- 1  → **Service** → **OK**.
- 2 **Instrument data** → **OK**.

F.2.5.5 Bus address

To enable the system components to communicate via the Testo databus, each system component has its own bus address which can be customized.

We recommend that you do not change the preset address.

Changing the bus address:

 The changed bus address will not be active until the next time the measuring system is started.

- 1  → **Service** → **OK**.
- 2 **Bus address** → **OK**.
- 3 Enter the value → .



G. Measuring

This chapter describes the measuring tasks that can be carried out with the product.

! Familiarity with the contents of the chapter *Operation* is assumed.

G.1 Preparing measurements

Setting the measuring system up:

- ▶ Set the fuel of the diesel engine that is to be measured, see *Setting fuel*.
- ▶ Activate the location to which the readings are to be assigned, see *Setting locations*.

Keeping gas outlets clear (see chapter C.2.1. ⑤)

When measuring, ensure that the gas outlets of the flue gas analyzer are exposed to allow the gas to escape unobstructed. Otherwise the measurement results may be distorted.



Dangerous mixture of gases

Danger of explosion!

- ▶ Always perform measurements in flue gas ducts.

! If there is a temperature change/change of location, the instrument must be zeroed prior to operation.

G.2 Flue gas measurement

There are two possible ways of carrying out a flue gas measurement. The flue gas analyzer must be in its protective case during the measurement in accordance with proper use!

G.2.1 Performing an individual or spot measurement

Readings are not automatically stored in the flue gas analyzer in this instance. The reading is only saved if the Save button is pressed during the measurement.

The flue gas analyzer must be calibrated or readjusted prior to the measurement (max. 6-8 hours beforehand) in accordance with country-specific statutory requirements. Observe the calibration specifications prescribed in MARPOL Annex VI and NOx Technical Code. A chosen load point (according to NOx Technical Code) must be maintained constantly. Once the load point is stable, start the flue gas measurement.

A function key must be assigned the function **PStart** (start measuring gas pump) in order to carry out a flue gas measurement, see *Assigning a function key*, see page 36.

! After measurements involving high concentrations and measurements over long periods of time, the instrument should be rinsed with fresh air so that the measuring cells can regenerate themselves again, see *Chapter Recommended rinse times*, page 7 .

Measuring:

- 1 Start measuring: .
- The readings are displayed.
- 2 Stop measuring and record the readings: .

G.2.2 Carrying out a measurement program

In this case, all readings are automatically stored in the flue gas analyzer during the course of the measurement program.

The flue gas analyzer must be calibrated or readjusted prior to the measurement (max. 6-8 hours beforehand) in accordance with country-specific statutory requirements. Observe the calibration specifications prescribed in MARPOL Annex VI and NOx Technical Code. A chosen load point (according to NOx Technical Code) must be maintained constantly. Once the load point is stable, start the flue gas measurement.

A function key must be assigned the function **Start** (start measurement program) in order to carry out a measurement program, see *Assigning a function key*.

Differential pressure and flow rate readings cannot be determined within one measurement program.

The measurement program must be activated, see *Program*.

Measuring:

- 1 Start the measurement program: .
- The measurement starts. The measurement program always begins with a rinse phase (duration: 6 min).
- Measuring phases (gas time) and rinsing phases (rinsing time) alternate according to the programmed values.

Option:

- ▶ Interrupt the measurement program manually: , start again with .



- The measurement program runs until the set end criterion has been reached. This is always followed by a rinse phase (duration: 2 min).
- The measurement program remains active even after the program has come to an end.
 - ▶ Deactivate the measurement program, see *Program*.

G.3 Differential pressure measurement

A differential pressure measurement is built into the flue gas analyzer. In conjunction with this, Pitot tubes can also be used to carry out velocity measurements simultaneously with the gas analysis. If desired, the instrument can then also calculate the mass flow.

A function key must be assigned the function **dP** (draught/differential pressure measurement) in order to carry out a differential pressure measurement, see *Assigning a function key*.

Measuring:

! Do not measure for longer than 5 min, as the drift of the pressure sensor means that the readings could be outside the tolerance limits.

Do not change between rechargeable battery and mains operation during the draught/differential pressure measurement (voltage fluctuations influence the measurement result)!

If you conduct the differential pressure measurement after a flue gas measurement, there will still be back pressure in the hose after the pump has stopped, which must be dispelled. This occurs within approx. 30 seconds.

Remove any residues of condensate in the flue gas probe (shake out the probe with the tip towards the floor).

When measuring the gas flow pressure, e.g. in gas heaters:



Warnung!

Dangerous mixture of gases

Danger of explosion!

- ▶ Make sure there are no leaks between the sampling point and the measuring instrument.
- ▶ Do not smoke or use naked flames during measurement.

1 Depressurize pressure inlets (ambient pressure).

2 Start measuring: .

- The pressure sensors are zeroed.

- 3 Pressurise the pressure inputs.
 - The readings are displayed.
- 4 End measurement: **OK**.
 - If a display field is assigned the parameter **dP**, the reading is copied into the measurement view.

G.4 Velocity measurement

A function key must be assigned the **V On** (flow measurement) function in order to carry out a flow measurement, see *Assigning a function key, page 36*. A display field must be assigned the necessary flow parameter (**Spd, Vols, MCO, MSO2, MNOx**) in order to display the readings. A temperature probe must be connected to the flue gas temperature probe input. The flow measurement can be carried out alongside a flue gas measurement.

To ensure correct measurement results, the parameters must be **pressure, Pitot tube factor** and **cross section**, as well as **ambient air dew point**.

Measuring:

- ! Do not measure for longer than 5 min, as the drift of the pressure sensor means that
 - the readings could be outside the tolerance limits.
- 1 Depressurize pressure inlets (ambient pressure).
- 2 Start measuring: **v On**.
 - The pressure sensors are zeroed.
- 3 Pressurise pressure inlets/insert the Pitot tube into the flow duct.
 - The readings are displayed.
- 4 Stop measuring and record the readings: **v Off**.

H. Care and maintenance

This chapter describes the action required in order to keep the product functioning properly.

H.1 Cleaning the flue gas analyzer

- ▶ If the housing of the flue gas analyzer is dirty, clean it with a damp cloth. Do not use any aggressive cleaning agents or solvents! Weak household cleaning agents and soap suds may be used.

H.2 Changing/retrofitting sensors

A slot bridge (0192 1552) must be inserted in slots which do not have a sensor. Used sensors must be disposed of as special waste!

The CO₂ IR sensor can only be changed/retrofitted by a Testo service centre.

The flue gas analyzer must be switched off and isolated from the mains supply.

- 1 Place the flue gas analyzer on its front.
- 2 Open the cover of the sensor compartment (clip lock) and remove.
- 3 If applicable: disconnect the sensor heater from the faulty sensor.
- 4 Disconnect the tube connections from the connecting nipples of the faulty sensor/bridge and remove the faulty sensor/bridge from the slot.

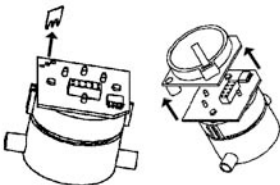

! Do not remove shorting jumpers/auxiliary circuit boards of the new sensors until immediately before installation. Do not leave the sensors without a shorting jumper/auxiliary circuit boards for longer than 15 min.

- ▶ CO, NO₂, SO₂, H₂S sensor:
Remove the shorting jumper.
- ▶ NO sensor:
Remove the auxiliary circuit board.

Sensors must be connected in the designated slots. These are marked accordingly.

Measuring cell type	Slot
O ₂	O2
CO	CO
NO	NO
NO ₂ , SO ₂	Set switch to Type A!

5 Insert a new sensor/bridge in the slot.

6 If applicable: connect the sensor heater to the sensor.

7 Attach tube connections to the connecting nipples of the sensor/bridge.

8 Replace the cover of the sensor compartment and close.

! After replacing an O₂ sensor, wait for an equalization period of 60 min to elapse before using the instrument again.

After installation (connection to the supply voltage), an NO sensor needs about 2 h before it is operational.

H.3 Calibrating/readjusting the sensors

See Chapter *F.2.2 Sensors*, page 55

H.4 Cleaning the flue gas probe

Soot or particle deposits on the probe pre-filter can be easily removed using a wire brush.

! The probe pre-filter cannot be exchanged. For safety reasons, the screw on the probe pre-filter is welded on and is not to be removed.

H.5 Replacing thermocouple

! Only remove the thermocouple if it is faulty.

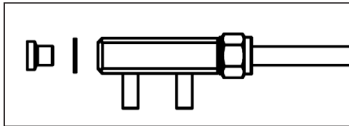

- Loosen the screw connection at the end of the handle with an Allen key (\varnothing 4 mm).

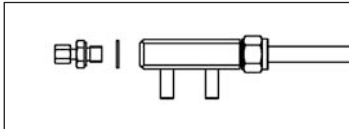

- Screw in new screw connection with new seal and tighten again.

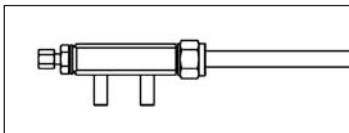

- Loosen union nut.

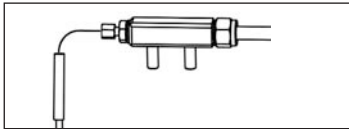

- Insert thermocouple.
- Tighten union nut by hand.



- Slide heat guard over handle.



- Screw on heat guard.

H.6 Changing the printer paper

See *Setting up the printer*, page 44

H.7 Changing the batteries/ rechargeable batteries

See *Changing rechargeable batteries*, page 27

H.8 Condensate container

With gas preparation fitted, the condensate is separated from the measuring gas and is led into a condensate container that is isolated from the gas path. In the case of longer measurements with moist flue gas, the condensate can be led off using a tube without any external air being carried along.

The fill level of the condensate container is indicated by the markings.

Emptying the condensate container

! The condensate consists of a weak mix of acids. Avoid contact with the skin. Make sure that the condensate does not run over the housing.



Condensate entering the gas path.

Damage to the measuring cells and flue gas pump!

- ▶ Do not empty the condensate container while the flue gas pump is in operation.

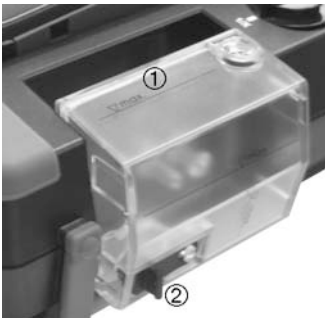

- 1 Detach the condensate container (①) horizontally from the flue gas analyzer.
- 2 Open the drain plug (②) and allow the condensate to drain into a sink.
- 3 Wipe off any drops still on the condensate outlet using a cloth and close the condensate outlet.
- 4 Attach the condensate container to the flue gas analyzer.

H.9 Checking/replacing the particle filter

Checking the particle filter:

- ▶ Check the particle filter of the flue gas analyzer for contamination at regular intervals: Check visually by looking through the window of the filter chambers.
Replace the filter if there are signs of contamination.

Replacing the particle filter:



- ! The filter chamber may contain condensate.
- 1 Open the filter chamber: Turn the filter cover (①) anticlockwise and remove.
- 2 Remove the spent filter and replace it with a new one (0554 3381).
- 3 Attach the filter cover and lock by turning it clockwise. The cross part of the filter cover must be aligned with the markings on the housing (②).

H.10 Cleaning/changing the pumps

! Disconnect the mains plug before carrying out maintenance work



1. Switch off the measuring instrument and disconnect the mains plug.
2. Remove the condensate container.
3. Unlock the three filter housings.
4. Unscrew the 8 Philips screws of the bottom of the housing.
5. Turn the measuring instrument back over and remove the upper part of the housing.

H.10.1 Cleaning the main gas pump

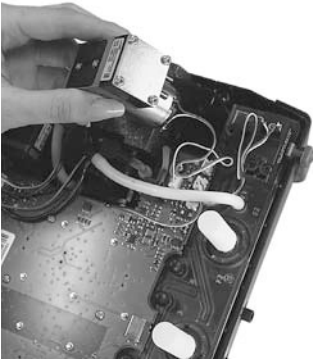

1. Remove the Philips screw from the plastic pump bracket.
2. Bend the plastic holder gently to one side.
3. Pull the gas pump upwards from the gas measuring block.
4. Unscrew the 4 fastening screws from the pump head of the main gas pump.
5. Pull off the pump head.
6. Remove the two circlips from the recesses on the pump head (front and rear).
7. Remove and clean the pump diaphragm (e.g. with white spirit).
8. If necessary, blow through the inlet and outlet fittings with compressed air.
9. Reattach the pump diaphragms with the circlips.
10. Attach the pump head to the main gas pump and fasten with the screws.
11. Replace the pump in the gas measuring block and fasten the pump to the plastic pump bracket with the Philips screw.
12. Add the upper part of the housing. Ensure that no cables are trapped.
13. Turn the measuring instrument over and tighten the 8 Philips screws.
14. Mount the filter housing and the condensate container.

H.10.2 Cleaning the purging pump/conveying pump for diluting gas

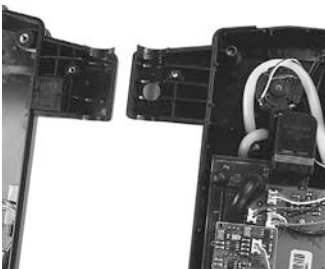

1. Unscrew the Philips screw in the plastic pump holder.
2. Bend the plastic holder gently aside.
3. Pull out the pump carefully.
4. Push the pump tool into the guides of the pump head.
5. Remove the pump tool from the pump head.

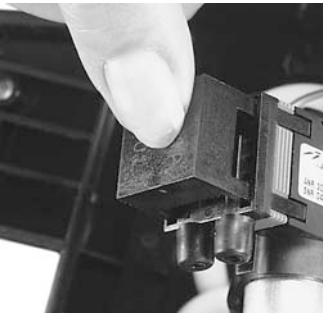

6. Remove the diaphragm holder from the pump head and remove the diaphragm.
7. Place the pump diaphragm in the diaphragm holder and insert in the pump head.
8. Place the pump head on the pump.
9. Remove “pump tool”.
10. Insert pump in the installation block.
11. Replace the pump in the gas measuring block and fasten the pump to the plastic pump bracket with the Philips screw.
12. Add the upper part of the housing. Ensure that no cables are trapped.
13. Turn the measuring instrument over and tighten the 8 Philips screws.
14. Mount the filter housing on the condensate container.

H.10.3 Changing the condensate pump

The condensate pump is only available in instruments with the gas preparation (GP) option.



- 1 Empty the condensation container.
- 2 Place the flue gas analyzer on its front, undo both screws of the pump compartment cover and remove the cover.
- 3 Unlock the two lateral clip locks of the condensate pump and withdraw the pump.
- 4 Disconnect the inlet and outlet tube from the connecting nipples of the flue gas analyzer.
- 5 Remove the bend protection spring from the inlet tube and push it onto the inlet tube of the new pump.
- 6 Attach the inlet and outlet tube to the connecting nipples of the flue gas analyzer.
- 7 Push onto the motor shaft until the clip locks engage. Make sure that the tubes are not pinched or constrained.
- 8 Attach the cover.

H.11 Changing the filter fleece in the gas cooler

The flue gas analyzer must be switched off and isolated from the mains supply.



- 1 Place the flue gas analyzer on its front.
- 2 Open the cover of the measuring cell compartment (clip lock) and remove.
- 3 Open the cover of the filter fleece (①) clockwise.
- 5 Replace the used filter with a new filter.
- 6 Close the cover.
- 7 Replace the cover of the sensor compartment and close.



H.12 Checking flue gas analyzer for leaks

Check the flue gas analyzer for leaks at regular intervals. This will help to ensure accurate measurement.

The gas sampling probe may not be connected to the flue gas analyzer when carrying out a gas-tightness test. The gas-tightness of the gas path in the flue gas analyzer testo 350-MARITIME can be tested by closing the flue gas input (see Ch. 3.3). The instrument must be switched on. A function key must be assigned the function **Pstart** (start measuring gas pump), see *Assigning a function key*, page 36. A display field of the measurement view must be assigned the parameter **Pump** (flue gas pump volumetric flow rate), see *Changing the display sequence*, see page 42.

- The measurement view is opened.
- 1 Close flue gas input (see Ch. 3.3.) in the flue gas analyzer (e. g. with a thumb).
- 2 Press .
- Volumetric flow rate less than or equal to 0.1 l/min: measuring system is not leaking.
- or-
- Volumetric flow rate greater than 0.1 l/min = measuring system is leaking.
 - ▶ Check the flue gas analyzer for leaks.

H.13 Recommended maintenance cycles

Component	Life	Application	Remedy
Measuring gas pump	1,200 h	general	▶ Replace entire pump
Diluting pump	1,200 h	general	▶ Replace entire pump
Hose pump	2,500 h	general	▶ Replace pump head with hose
	5,000 h	general	▶ Replace entire pump
Fleece in gas cooler	1,200 h	Fuel: gas, light fuel oil	▶ Clean the housing, replace fleece
Condensate vessel	25 ml condensate	general	▶ Free draining of condensate must be ensured

I. Questions and answers

This chapter gives answers to frequently asked questions.

Question	Possible causes	Remedy
Rech. battery low	-	► Switch to mains operation.
Measuring instrument keeps switching off by itself or measuring instrument will not switch on	Batteries/rech. batteries empty.	► Charge the battery or change to mains operation (see <i>Operation, page 27</i>).
NO value drifts	Aux. voltage for NO measuring cell was interrupted, e.g. by change of cell	► Wait until cell is regenerated. Stable NO measuring not possible until approx. 2 h after.
Double module	One measuring cell of the same type is already inserted.	-
Dilution	Gas flow rate in dilution path too high / too low.	► Please contact your dealer or Testo Customer Service.
O ₂ cell used up	-	► Replace O ₂ measuring cell.
... signal too high	Signal of indicated measuring cell is too high.	► Wait until regenerated (repeat zeroing starts automatically).
... Signal not stable	Signal of indicated measuring cell drifts too much (faulty).	► Replace measuring cell.
... Switch-off	Reading of indicated measuring cell is above the set switch-off threshold.	-
Instrument temperature	Instrument temperature is outside the operating temperature	-
Pump volumetric flow rate	Gas flow rate too low (filter clogged) or gas flow rate too high (positive pressure)	► Check gas path/filter.
Gas cooling system	Gas cooler not working (faulty).	► Please contact your dealer or Testo Customer Service.
Cell temperature too high	O ₂ cell temperature outside the specifications	-
Probe break or probe not connected	Temperature sensor not connected or thermocouple broken	Connect temperature probe or replace thermocouple
Ambient air temperature stored	No AT probe connected. The measured temperature of the flue gas analyzer probe is stored as the ambient air temperature	
The input has effects on values entered previously	The programming relates to a memory program, e.g. end criterion is invalid because start criterion was changed.	
Cell no. X of sensor faulty	The cell on slot no. X is faulty and must be replaced	Contact your dealer or Testo Customer Service.
Check CO ₂ IR sensor	Various	Perform zeropoint calibration. If this is no longer possible, contact your dealer or Testo Customer Service.

If we could not answer your question, please contact your dealer or Testo Customer Service. For contact details see the reverse side of this document or the web page www.testo.com/service-contact.



J. Technical data

J.1 Checks and certifications

The testo 350-MARITIME has the following certificate:
Germanischer Lloyd (GL) certificate no. 59488 - 08 HH and DET NORSKE VERITAS
(DNV)-Certificate No. A-11316 in accordance with MARPOL 73/78 Annex VI and
NOx Technical Code and (MEPC.177(58)) guideline

Type Approval Certificate



This is to certify that the undernoted product(s) has/have been tested in accordance with the relevant requirements of the GL Type Approval System.

Certificate No.	59 488 - 08 HH
Company	Testo AG Testostr. 1 79853 Lenzkirch, GERMANY
Product Description	Exhaust gas measuring device
Type	"testo 350-MARITIME" including sensors as listed below and the "MARITIME"-components: Control-Unit, sample probe and protective case
Environmental Category	A, D, EMC2
Technical Data / Range of Application	Mobile exhaust gas measuring device for NOx, CO, CO2, SO2 and O2. Component / Sensor type / Range NO / TNF / 0-3000 vol.-ppm NO2 / TND / 0-500 vol.-ppm CO / TCHI / 0-3000 vol.-ppm CO2 / TCO2 / 0-40 vol.-% O2 / TO2 / 0-25 vol.-% SO2 / TSF / 0-3000 vol.-ppm Power supply: 11... 40V DC or 110 ... 230V AC 50/60Hz Sample pressure range: -200hPa ... 50hPa Ambient temperature: 5°C ... 50°C Protective case: part no. 05163500 Software Version: Analyzer 2.10, Control-Unit: 2.03 Environmental category "D" only for the sample probe
Test Standard	Guidelines for the Performance of Type Approvals, Chapter 2, Edition 2003; MARPOL 73/78 Annex VI and NOx Technical Code; MEPC.103(49)
Documents	Test reports: TÜV ME -E 1052-00/06, Testo Climate, DT2-TESTO-2009-01, Vibration DT2-TESTO-2008-01/-02, Insulation resistance, High voltage, EMV, EMV Labor no. 2008001098; Equivalence reports 42-967-50/0608 and I-0409; drawings, part lists acc. to submitted files
Remarks	The "testo 350-MARITIME" should operate always with the Control-Unit "MARITIME" in the protective case. Operating instruction must be advised.
Valid until	2013-09-18
Page	1 of 2
File No.	I.A.02
Hamburg, 2009-05-18	

Type Approval Symbol



Germanischer Lloyd

Hans-Joachim Götze
Hans-Joachim Götze

Hilmar Brumm
Hilmar Brumm

This certificate is issued on the basis of "Guidelines for the Performance of Type Approvals Part 1, Procedure"



Type Approval Certificate



This is to certify that the undemoted product(s) has/have been tested in accordance with the relevant requirements of the GL Type Approval System.

Certificate No. 59 488 - 08 HH

Further Technical data / Range of Application

The "testo 350-MARITIME" is found to comply with MEPC.103 (49), Analysing equipment, Sections 1.1 Emission Species Measurement and 1.2 Analyser specifications. This includes some parts of MARPOL Annex VI and the NOx Technical Code, Appendix 3 and 4, as indicated in the MEPC.103(49).

The "testo 350-MARITIME" is found to be within the requirements of MEPC.103(49) MARPOL Annex VI and NOx Technical Code and suitable as a component of a complete monitoring system. In order to completely fulfill the requirements of MEPC.103(49), MARPOL Annex VI and NOx Technical Code for the On-board verification procedure "Direct measurement and monitoring method", additional equipment will have to be installed.

Equivalence of the alternative Sensors have been demonstrated under surveillance and to the satisfaction of GL in accordance with ISO 8178:2006 Part 1, Section 7 and Appendix D.

The "testo 350-MARITIME" must be operated and calibrated in accordance with the requirements and intervals as specified in MEPC.103(49) Section 3.3

CO, NO, SO2 and NO2 testing

-Principle of detection (MEPC.103(49), 1.1.3.1 and 1.1.3.4): Equivalence tests have been carried out.

-Measurement error (NOx Technical Code, Appendix 3, 1.5).

-Repeatability (NOx Technical Code, Appendix 3, 1.6).

-Noise (NOx Technical Code, Appendix 3, 1.7).

-Zero and span drift (NOx Technical Code, Appendix 3, 1.8 and 1.9).

-Interference effect (NOx Technical Code, Appendix 4, 8).

-Leakage test (NOx Technical Code, Appendix 4, 4).

-Calibration curve (NOx Technical Code, Appendix 4, 5.5.1).

CO2 and O2 testing

-Principle of detection (MEPC.103(49), 1.1.3.2 and 1.1.3.3).

-Measurement error (NOx Technical Code, Appendix 3, 1.5).

-Repeatability (NOx Technical Code, Appendix 3, 1.6).

-Noise (NOx Technical Code, Appendix 3, 1.7).

-Zero and span drift (NOx Technical Code, Appendix 3, 1.8 and 1.9).

-Leakage test (NOx Technical Code, Appendix 4, 4).

-Calibration curve (NOx Technical Code, Appendix 4, 5.5.1).

Valid until 2013-09-18

Page 2 of 2

File No. IA.02

Hamburg, 2009-05-18

Germanischer Lloyd

Type Approval Symbol



Hans-Joachim Götze

Hilmar Brumm

This certificate is issued on the basis of "Guidelines for the Performance of Type Approvals Part 1, Procedure"



DET NORSKE VERITAS

TYPE EXAMINATION CERTIFICATE

CERTIFICATE NO. A-11316
This Certificate consists of 4 pages

This is to certify that the
Gas Detectors for Exhaust Gas Emissions
with type designation
testo 350-MARITIME

Manufactured by
Testo AG
Lenzkirch, Germany

is found to comply with
Det Norske Veritas' Rules for Classification of Ships, High Speed & Light Craft and
Det Norske Veritas' Offshore Standards
Revised MARPOL 73/78: Annex VI and the NOx Technical Code 2008
(IMO Resolution MEPC.177(58))

Application
The testo 350-MARITIME is a portable exhaust gas measuring device for combustion engines. It is examined for use as a component of a complete monitoring system in a "Direct measurement and monitoring method" On-board NOx verification system.

Location classes:

Type	Temperature	Humidity	Vibration	EMC
testo 350-MARITIME	A	B	A	A
Sample probe	A	B	B	A

Place and date
Høvik, 2009-12-01
for DET NORSKE VERITAS AS

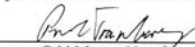
Odd Magne Nesvåg
Head of Section



Local Office
DNV Essen

This Certificate is valid until
2013-12-31

 
Ståle Sneen / Vidar Johansen
Surveyors

Notice: This Certificate is subject to terms and conditions overlaid. Any significant change in design or construction may render this Certificate invalid. The validity date relates to the Type Examination Certificate and not to the approval of equipment/systems installed.

If any person suffers loss or damage which is proved to have been caused by any negligence act or omission of Det Norske Veritas, then Det Norske Veritas shall pay compensation to such person for the proved direct loss or damage. However, the compensation shall not exceed an amount equal to ten times the fee charged for the service in question, provided that the maximum compensation shall never exceed USD 2 million in this provision. Det Norske Veritas' shall mean the Foundation Det Norske Veritas as well as all its subsidiaries, directors, officers, employees, agents and any other acting on behalf of Det Norske Veritas.

Cert. No.: A-11316
File No.: 760.30
Job ID: 262.1-007767-1**Product description**

testo 350-MARITIME is a portable measurement instrument for measuring exhaust gas emissions from combustion engines, in compliance with the regulations for direct measurement and monitoring methods laid down in the Revised MARPOL 73/78 Annex VI and the NOx Technical Code 2008 (IMO Resolution MEPC.177(58)), Chapter 6.4 and Appendix 8.

The Type Examination covers the following hardware:

Type	Description
testo 350-MARITIME	Portable exhaust gas analyser for NO _x , CO, CO ₂ , SO ₂ and O ₂
Sample probe	Gas sampling probe with pre-filter
Case	Protective case

The Type Examination covers the following software:

Analyser: Software version 2.10
Control Unit: Software version 2.03

The software revisions are recorded in Testo's internal QA system.

Power supply:

Mains operation (110/230V AC 50/60Hz)
DC voltage operation (11V – 40V DC)

Technical specification:

Component	Range
O ₂	0 - 25 vol.%
CO	0 - 3,000 ppm
NO	0 - 3,000 ppm
NO ₂	0 - 500 ppm
SO ₂	0 - 3,000 ppm
CO ₂ (IR)	0 - 40 vol.%

The measurement range is variable for each application, and is dependent on the test gas concentration selected.

Application/Limitation

The Type Examination covers hardware and software listed under Product description above.

The "testo 350-MARITIME" must be operated and calibrated in accordance with the requirements and intervals as specified in MEPC.177(58) section 6.4.8.

The "testo 350-MARITIME" shall always be operated with the Control Unit "MARITIME" in the protective case as specified in the instruction manual.



Cert. No.: A-11316
File No.: 760.30
Job ID: 262.1-007767-1

Equivalence of alternative sensors has been demonstrated in accordance with ISO 8178:2006 Part 1, Section 7 and Appendix D.

Changes to Revised MARPOL 73/78 Annex VI or MEPC.177(58) may, depending on their nature, render this certificate invalid if these changes enter into force before the expiry date of this certificate.

Type Examination documentation

testo 350-MARITIME – Environmental Test Reports, 2008	42-871-50/0608
testo 350-MARITIME – Equivalence Report, June 2008	42-967-50/0608
testo 350-MARITIME – Supplementary document to report 42-967-50/608, April 2009	I-0409
Vibration Testing with Sulphur Dioxide Test Gas, 2009-07-24	DT2-TESTO-2009-01-EN
testo 350-MARITIME – Instruction Manual	0970 3506 en 01 V02.22 en V02.06

Tests carried out

Environmental testing

- Applicable tests according to DNV Standard for Certification No. 2.4, April 2006

CO, NO, NO₂ and SO₂ testing according to NO_x Technical Code 2008 (MEPC.177(58)):

- Principle of detection	(Appendix 3, 1.2.10 & Appendix 8, 2.1.1.1)
	Equivalence tests have been carried out.
- Measurement error	(Appendix 3, 1.6)
- Repeatability	(Appendix 3, 1.7)
- Noise	(Appendix 3, 1.8)
- Zero drift	(Appendix 3, 1.9)
- Span drift	(Appendix 3, 1.10)
- Interference effect	(Appendix 4, 9)
- Leakage test	(Appendix 4, 4)
- Calibration curve	(Appendix 4, 5.5.1)

CO₂ and O₂ testing according to MEPC.177(58):

- Principle of detection	(Appendix 3, 1.2.12 & Appendix 8, 2.1.1.5)
- Measurement error	(Appendix 3, 1.6)
- Repeatability	(Appendix 3, 1.7)
- Noise	(Appendix 3, 1.8)
- Zero drift	(Appendix 3, 1.9)
- Span drift	(Appendix 3, 1.10)
- Leakage test	(Appendix 4, 4)
- Calibration curve	(Appendix 4, 5.5.1)



Cert. No.: A-11316
File No.: 760.30
Job ID: 262.1-007767-1

Marking of product

The product is to be marked with the manufacturer's name, and the product's type designation and serial number.

Certificate retention survey

The scope of the retention/renewal survey is to verify that the conditions stipulated for the type are complied with, and that no alterations are made to the product design or choice of systems, software versions, components and/or materials.

The main elements of the survey are:

- Ensure that type approved documentation is available
- Inspection of factory samples, selected at random from the production line (where practicable)
- Review of production and inspection routines, including test records from product sample tests and control routines
- Ensuring that systems, software versions, components and/or materials used comply with type approved documents and/or referenced system, software, component and material specifications
- Review of possible changes in design of systems, software versions, components, materials and/or performance, and make sure that such changes do not affect the type approval given
- Ensuring traceability between manufacturer's product type marking and the type approval certificate

Retention survey is to be performed at least every second year and at renewal of this certificate.

END OF CERTIFICATE

EC Certificate of Conformity Quality System (Module D)



Germanischer Lloyd as the notified body performing the quality assessment procedures certifies that the manufacturer maintains and applies a quality system which is in compliance with the requirements of the Marine Equipment Directive (MED) 96/98/EC, as amended, ensuring that the equipment identified below is conform to the type as described in the EC Type Examination Certificate, subject to any conditions in the schedule attached hereto.

Certificate No. 94 414 - 10 HH

Manufacturer **Testo AG**
Testostr. 1
79853 Lenzkirch, GERMANY

Product Description **Onboard NOx monitoring and recording device**

Product Name **testo 350-MARITIME**

Trade Name **testo 350-MARITIME**

EC Type Examination
Certificate No. 94 366 - 10 HH
Date of Issue 2010-04-30
Valid Until 2015-04-29
Notified Body ID No. 0098

Related Directive 2009/26/EC
Equipment Section **Marine pollution prevention**
Annex A.1 Item No. A.1/2.8

Date of Issue 2010-04-30
Expiry Date 2015-04-29

Germanischer Lloyd



Nils Wegener

Notified Body No.: 0098

Page 1 of 2



Certificate No: 94 414 - 10 HH Date of Issue: 2010-04-30

Schedule of Approval

Remarks

Audit report is based on GL Audit performed on 07./08./09.10.2009 in Lenzkirch. No additional Audit for issuance of MED Module D for Testo 350 Maritime has been performed, yet.

Notes:

This certificate authorises the manufacturer in conjunction with the EC Type Examination (Module B) Certificate of the equipment listed before to affix the Mark of Conformity (wheelmark) to the product described herein.

This certificate loses its validity if the manufacturer makes any changes or modifications to the approved quality system, which have not been notified to, and agreed with the notified body named on this certificate and/or after lapse of time, withdrawal or revocation of the EC Type Examination (Module B) Certificate.

Wheelmark Format and application:



0098/yy

0098
yy

Notified Body number undertaking quality surveillance
Last two digits of year in which the mark is affixed

EC Certificate Type Examination (Module B)



This is to certify that:

Germanischer Lloyd, a Notified Body under the terms of the Marine Equipment Directive 96/98/EC of 20 December 1996, did undertake the relevant type approval procedures for the equipment identified below which was found to be in compliance with the requirements of Marine Equipment Directive (MED) 96/98/EC as amended, subject to any conditions in the schedule attached hereto.

Certificate No.	94 366 - 10 HH
Applicant	Testo AG Testostr. 1 79853 Lenzkirch, GERMANY
Manufacturer	Testo AG Testostr. 1 79853 Lenzkirch, GERMANY
Product Description	Onboard NOx monitoring and recording device
Product Name	testo 350-MARITIME
Trade Name	testo 350-MARITIME
Specified Standards	Guidelines for the Performance of Type Approvals, Chapter 2, Edition 2003; MARPOL Annex VI and NOx Technical Code; MEPC.103(49)
Related Directive	2009/26/EC
Equipment Section	Marine pollution prevention
Annex A.1 Item No.	A.1/2.8
Date of Issue	2010-04-30
Expiry Date	2015-04-29

Germanischer Lloyd

Notified Body No.: 0098

Page 1 of 3



Nils Wegener



Certificate No: 94 356 - 10 HH Date of Issue: 2010-04-30

Schedule of Approval

Additional Standards

MARPOL Annex VI Reg. 13 and NOx Technical Code

Approval Documentation

GL Type Approval Certificate 58488-08 HH

Test reports: TÜV ME-E 1052-00/06, Testo Climate, DT2-TESTO-2009-01, Vibration DT2-TESTO-2008-01/02, insulation resistance, High voltage, EMV, EMV Labor no. 2008001098; Equivalence reports 42-967-50/0608 and 1-0409; drawings, part lists acc. to submitted files

Technical Data

Mobile exhaust gas measuring device for NOx, CO, CO₂, SO₂ and O₂.

Component / Sensor type / Range: NO / TNF / 0-3000 vol.-ppm
NO₂ / TND / 0-500 vol.-ppm
CO / TCH / 0-3000 vol.-ppm
CO₂ / TCO₂ / 0-40 vol.-%
O₂ / TO₂ / 0-25 vol.-%
SO₂ / TSF / 0-3000 vol.-ppm

The measurement range is variable for each application, and is dependent on the test gas concentration selected.

Power supply: 11 ... 40V DC or 110 ... 230V AC 50/60Hz

Sample pressure range: -200hPa ... 50hPa

Ambient temperature: 5°C ... 50°C

Protective case: part no. 05163500

Software Version: Analyzer 2.10, Control-Unit: 2.03

Environmental category "D" only for the sample probe

Further Technical data / Range of Application

The "testo 350-MARITIME" is found to comply with MEPC.103(49), Analysing equipment, Sections 1.1 Emission Species Measurement and 1.2 Analyser specifications. This includes some parts of MARPOL Annex VI and the NOx Technical Code, Appendix 3 and 4, as indicated in the MEPC.103(49).

The "testo 350-MARITIME" is found to be within the requirements of MEPC.103(49) MARPOL Annex VI and NOx Technical Code and suitable as a component of a complete monitoring system. In order to completely fulfil the requirements of MEPC.103(49), MARPOL Annex VI and NOx Technical Code for the On-board verification procedure "Direct measurement and monitoring method", additional equipment will have to be installed.

Equivalence of the alternative Sensors have been demonstrated under surveillance and to the satisfaction of GL in accordance with ISO 8178:2006 Part 1, Section 7 and Appendix D.

The "testo 350-MARITIME" must be operated and calibrated in accordance with the requirements and intervals as specified in MEPC.103(49) Section 3.3

CO, NO, SO₂ and NO₂ testing

- Principle of detection (MEPC.103(49), 1.1.3.1 and 1.1.3.4): Equivalence tests have been carried out.
- Measurement error (NOx Technical Code, Appendix 3, 1.5).
- Repeatability (NOx Technical Code, Appendix 3, 1.6).



Certificate No: 94 366 - 10 HH Date of Issue: 2010-04-30

- Noise (NOx Technical Code, Appendix 3, 1.7).
- Zero and span drift (NOx Technical Code, Appendix 3, 1.8 and 1.9).
- Interference effect (NOx Technical Code, Appendix 4, 8).
- Leakage test (NOx Technical Code, Appendix 4, 4).
- Calibration curve (NOx Technical Code, Appendix 4, 5.5.1).

CO2 and O2 testing

- Principle of detection (MEPC.103(49), 1.1.3.2 and 1.1.3.3).
- Measurement error (NOx Technical Code, Appendix 3, 1.5).
- Repeatability (NOx Technical Code, Appendix 3, 1.6).
- Noise (NOx Technical Code, Appendix 3, 1.7).
- Zero and span drift (NOx Technical Code, Appendix 3, 1.8 and 1.9).
- Leakage test (NOx Technical Code, Appendix 4, 4).
- Calibration curve (NOx Technical Code, Appendix 4, 5.5.1).

Remarks

The "testo 350-MARITIME" should operate always with the Control-Unit "MARITIME" in the protective case. Operating instruction must be advised.

Limitations on the acceptance or use of the product

GL Environmental Category A,D, EMC2

Notes:

This certificate is valid for equipment, which is conform to the approved type. The manufacturer shall inform Germanischer Lloyd, as the Notified Body, of any modifications or changes to the approved equipment.

Should the specified regulations or standards be amended during the validity of this certificate, the product is to be re-approved before being placed on board a vessel to which the amended regulations or standards apply.



The mark of conformity may only be affixed to the above type approved equipment and a Manufacturer's Declaration of Conformity issued when the production-surveillance module (D, E or F) of Annex B of the MED is fully complied with and controlled by a written inspection agreement with a Notified Body.



РОССИЙСКИЙ МОРСКОЙ РЕГИСТР СУДОХОДСТВА
RUSSIAN MARITIME REGISTER OF SHIPPING

6.8.3



СВИДЕТЕЛЬСТВО О ТИПОВОМ ОДОБРЕНИИ
TYPE APPROVAL CERTIFICATE

Изготовитель
Manufacturer **Testo AG**

Адрес **Testostrasse 1, 79853 Lenzkirch, Germany.**

Address

Изделие*
Product* **Анализатор выпускных газов типа
testo 350-MARITIME.**

**Exhaust gas analyser
of testo 350-MARITIME type .**

Код номенклатуры **15130100**
Code of nomenclature

На основании освидетельствования и проведенных испытаний удостоверяется, что выше-упомянутое(ые) изделие(я) удовлетворяет(ют) требованиям Российского морского регистра судоходства.
This is to certify that on the basis of the survey and tests carried out the above mentioned item(s) complies(y) with the requirements of Russian Maritime Register of Shipping.

*Часть XV "Автоматизация" Правил классификации и постройки морских судов 2010 г. издания; Конвенция МАРПОЛ 73/78, Приложение VI; Резолюция МЕРС.177(58) Поправки к Техническому кодексу по контролю выброса окислов азота из морских дизельных двигателей.
Part XV "Automation" of Rules for the classification and construction of sea-going ships, Edition 2010; Convention MARPOL 73/78, Annex VI; Resolution MEPC.177(58) Amendments to the Technical Code on control of emission of nitrogen Oxides from marine diesel engines.

Настоящее Свидетельство о типовом одобрении действительно до **24.09.2015**
This Type Approval Certificate is valid until

Настоящее Свидетельство о типовом одобрении теряет силу в случаях, установленных в Правилах технического наблюдения за постройкой судов и изготовлением материалов и изделий для судов.
This Type Approval Certificate becomes invalid in cases stipulated in Rules for the Technical Supervision during Construction of Ships and Manufacture of Shipboard Materials and Products.

Дата выдачи **24.09.2010** № **10.04101.250**
Date of issue

Российский морской регистр судоходства
Russian Maritime Register of Shipping

подпись
signature

В.В. Морозов/V. Morozov
(фамилия, инициалы
name

*Дополнительную информацию см. на обороте.
Additional information on reverse side.

Технические данные
Technical data

Диапазон измерения:

O2	0 - 25 % (объем)
CO	0 - 3,000 ppm
NO	0 - 3,000 ppm
NO2	0 - 500 ppm
SO2	0 - 3,000 ppm
CO2 (IR)	0 - 40 % (объем)

Напряжение питания: от 11 В до 40 В постоянного тока или 110/230 В, 50/60 Гц
Температура окружающей среды: от +5°C до +50°C

Measurement Range:

O2	0 - 25 vol.%
CO	0 - 3,000 ppm
NO	0 - 3,000 ppm
NO2	0 - 500 ppm
SO2	0 - 3,000 ppm
CO2 (IR)	0 - 40 vol.%

Power supply: up 11V to 40V DC or 110/230V AC 50/60Hz
Ambient temperature: up 5°C to 50°C

Техническая документация и дата ее одобрения Российским морским регистром судоходства
Technical documentation and the date of its approval by Russian Maritime Register of Shipping

Техническая документация одобрена письмом No. 250-011-1-229 от 24.09.2010 г.

Technical documentation approved by the letter No. 250-011-1-229 of 24.09.2010.

Образец изделия испытан под техническим наблюдением Российского морского регистра судоходства.
Product's specimen has been tested under the technical supervision of Russian Maritime Register of Shipping.

Акт № 10.02045.250 от 24.09.2010
Report No. _____ of _____

Область применения и ограничения
Application and limitations

Анализатор выпускных газов "testo 350-MARITIME" должен использоваться, а также подвергаться калибровке в соответствии с требованиями и интервалами предписанными Резолюцией МЕРС.177(58) Поправки к Техническому кодексу по контролю выброса окислов азота из морских дизельных двигателей.

The exhaust gas analyser "testo 350-MARITIME" must be operated and calibrated in accordance with the requirements and intervals as specified in Resolution МЕРС.177(58) Amendments to the Technical Code on control of emission of nitrogen Oxides from marine diesel engines.

Вид документа, выдаваемого на изделие
Type of document issued for product

Изделия должны поставляться с копией настоящего Свидетельства о типовом одобрении.

The products shall be delivered with the copy of this Type Approval Certificates.



J.2 Measuring ranges and accuracies

Parameter	Measuring range	Tolerance
°C, exhaust gas	-40 - +1,000 °C	max. ± 5 K
O ₂	0 - 25 vol.%	According to MARPOL, Annex VI or NOx Technical Code
CO	0 - 3,000 ppm	
NO	0 - 3,000 ppm	
NO ₂	0 - 500 ppm	
SO ₂	0 - 3,000 ppm	
CO ₂ (IR)	0 - 40 vol.%	
P _{abs}	600 - 1,150 hPa	± 5 hPa at 22 °C ± 10 hPa at -5 - +45 °C

Parameter	Measuring range	Accuracy	Resolution	Response time ¹⁾
dP	-200 - 200 hPa ±1.5% of reading	±0.5 hPa (-49.9 - 49.9 hPa) (rest of range)	0.1 hPa	-
Temperature	-40 - 1,000 °C	max. ±5 °K	0.1 °C	depending on probe
Efficiency	0 - 120%	-	0.1%	-
Flue gas loss	-20.0 - 99.9%	-	0.1%	-

¹⁾ Recommended minimum duration of measurement to guarantee correct readings: 3 min

Testo 350-MARITIME flue gas analyzer, test gas concentrations

Parameter	Measuring range
CO	500 ppm (in N ₂)
CO ₂	10% (in N ₂)
NO	1,000 ppm (in N ₂)
NO ₂	100 ppm (in synthetic air)
SO ₂	1,000 ppm (in N ₂) (maximum)

J.3 Other instrument data

Characteristic	Values
Measuring system	
Operating temperature	+5 - +50 °C
Storage/transport temperature	-10 - 50 °C
Housing	ABS
Guarantee (according to Testo guarantee conditions)	Measuring instrument: 24 months, flue gas probe: 24 months, thermocouple: 12 months, rechargeable battery: 12 months Measuring cells: NO ₂ measuring cell: 12 months, O ₂ measuring cell: 18 months, CO ₂ (IR) measuring cell: 24 months, CO measuring cell: 12 months or max. 275,000 ppmh filter life, NO measuring cell: 12 months or max. 70,000 ppmh filter life SO ₂ measuring cell: 12 months
testo 350-MARITIME control unit	
Power supply	4x mignon AA 1.5 V
Battery service life	approx. 8 h
Dimensions (L x W x H)	252 x 115 x 58 mm
Weight	approx. 850 g
testo 350-MARITIME flue gas analyzer	
Power supply	Rechargeable battery pack (8.4 V/4.5 Ah) Integrated mains unit (90 - 260 V, 47-63 Hz, 0.3 A/230 V AC, 0.5 A/110 V AC)
Rechargeable battery charge time	approx. 4-5 h
Dimensions (L x W x H)	395 x 275 x 95 mm
Weight	approx. 3,200 g
Memory	250,000 readings
Max. flue gas positive pressure	50 hPa
Max. underpressure	200 hPa
Pump volumetric flow rate	1.0 m/s, monitored
Diluting gas	Fresh air or nitrogen
Max. flue gas dust load	20 g/m ³
Max. humidity load	70 °Ctd at measuring inlet
Dew point temperature	at the measuring inlet of the flue gas analyzer



J.4 Recommended rinse times

Recommended rinse times for measurements involving high concentrations and measurements over long periods of time:

- Rinsing the instrument: Expose the probe to fresh air and start flue gas measurement.

Parameter	Concentration [ppm]	Measurement period [min]	Rinse time [min]	Calibration cycles/ Month	Filter life [ppm/h]
CO	50	60	05	3	275,000 (NOx/SO2)
	100	30	05		
	200	20	10		
	500	10	10		
	1,000	10	15		
	2,000	10	20		
	4,000	5	30	1	
	8,000	5	45		
	10,000	5	60		
NO	50	60	05	3	70,000 (SO2)
	100	45	05		
	200	30	05		
	500	20	10		
	1,000	10	10	1	
	2,000	10	20		
	3,000	5	30		
NO2	10	60	05	3	
	20	45	05		
	50	30	05		
	100	20	10		
	200	10	10		
	500	10	20		
SO2	50	60	05	3	200,000 (H2S/HCl)
	100	30	05		
	200	20	10		
	500	15	10		
	1,000	10	10		
	2,000	10	20	1	
	5,000	05	40		

J.5 Principles of calculation

J.5.1 Fuel parameters

Fuel	Designation	Max. permissible	Cc carbon	Ch hydrogen	α	Source:
		S content (%) (mass)	content (%) (mass)	content (%) (mass)		
Distillate fuel oil, DM	DMX	1.0	86.2	13.6	~1.88	Draft NTC 2008, ISO 8217-3: 2005
	DMA	1.5				
	DMB	2				
	DMC	2				
Residual fuel oil, RM	RMA 30	3.5	86.1	10.9	~1.51	Draft NTC 2008, ISO 8217-3: 2005
	RMB 30	3.5				
	RMD 80	4				
	RME 180	4.5				
	RMF 180	4.5				
	RMG 380	4.5				
	RMH 380	4.5				
	RMK 380	4.5				
	RMH 700	4.5				
	RMK 700	4.5				
Rapeseed oil methyl ester	RME	0	77.2	12.0	~1.85	ISO 8178-1:2006
Low-sulphur diesel	MDO 0.1 S	0.1	86.2	13.6	~1.88	None
2 x user-defined fuel			Input	Input	Calculated	None



K. Accessories / spare parts

This chapter gives important accessory and spare parts for the product.

Designation	Article no.
Flue gas probes	
Engine probe with filter and hose, 2.20 m	0600 7551
Engine probe with filter and hose, 5 m	0600 7553
Thermocouple, 2.2 m	0600 8894
Thermocouple, 5 m	0600 8895
Spare probe shaft with filter	0554 7455
Measuring cells (replacement)	
O ₂	0390 0070
CO	0390 0088
NO	0390 0074
NO ₂	0390 0075
SO ₂	0390 0081
Measuring cells (for retrofitting by Service)	
SO ₂	0554 3381
Miscellaneous	
Thermal paper for printer (6 rolls)	0554 0569
Rechargeable battery pack for flue gas analyzer	0554 1098
Rechargeable battery pack for control unit	0554 1097
Filter for flue gas analyzer, 20 pieces, yellow	0554 3381
Testo databus connecting cable, 2 m	0449 0042
Testo databus connecting cable, 5 m	0449 0043
Testo databus connecting cable, 20 m	0449 0044
Refill pack for CO ₂ filter granulate	0554 0369
Measuring gas pump	0239 0009
Pump diaphragm for measuring gas pump	0193 0049
Purging and diluting pump	0239 0014
Pump diaphragm for purging and diluting pump	0193 0072
Cassette for hose pump cartridge	0440 0013

For a complete list of all accessories and spare parts, please refer to the product catalogues and brochures or look up our website at: www.testo.com

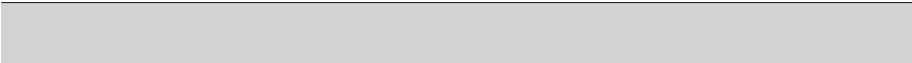

testo AG

Postfach 11 40, D-79849 Lenzkirch

Testo-Straße 1, D-79853 Lenzkirch

Telephone: +49 (0)7653-681-0

Fax: +49 (0)7653-681-100

E-mail: info@testo.de

Internet: <http://www.testo.com>