



ATS-850E-M THERMOSTREAM®

-90° to +300°C

Designed for **60Hz operation only**, this Advanced Temperature Source is for fast and precise thermal conditioning of components, parts, hybrids, modules, subassemblies, and printed circuit boards. Capable of ultra-low temperatures **without** the use of Liquid Nitrogen (LN₂) or Liquid Carbon Dioxide (LCO₂).

PERFORMANCE:

Temperature Range* - No LN₂ or LCO₂ Required

-90 to +300°C

Transition Rate*

-55 to +125°C, approx. 10 seconds or less

125 to -55°C, approx. 10 seconds or less

System Airflow Output*

4 to 18scfm (1.9 to 8.5 l/s) Continuous

TEMPERATURE CONTROL:

Temperature Display & Resolution

+/- 0.1°C

Temperature Accuracy

1.0°C (when calibrated against NIST standard)

DUT Temperature Control

Proprietary control algorithm enables DUT temperature to be directly controlled

DUT Sensor Ports

Internal diode, thermocouples (T & K), RTD (100 Ohm platinum)



E Series Systems Equipped with Embedded Software Controls, Eliminating Windows® OS

- Significant reduction in security vulnerabilities
- Minimizes software and hardware obsolescence concerns
- Improved responsiveness of the touch screen
- Faster system boot and startup times

FEATURES:

Frost Free Feature

Dry air purge for tester interface, prevents condensation: 0.5 to 3scfm (0.25 to 1.5 l/s)

ECO Friendly Features

- Automatic Power Reduction: reduces power usage during idle periods
- Heat Only Mode: reduces power usage when cold temperatures are not used

Heated Defrost Feature

Quickly removes moisture buildup from internal chiller

Fully Adjustable Thermal Head

Thermal Cap

5.5 inch ID, High Temperature Rated Thermal Cap or optional

- Embedded Control System
- Local & Remote Operations
- On-Screen Help
- Ethernet, IEEE-488, RS232 ports
- USB, keyboard, mouse, & printer ports
- Customizable and savable test setups
- Program & Datalog Storage (via ethernet or USB)
- User Defined Temperature Limits

**Under nominal operating conditions
Ultimate low: (±1°C) achieved at 18scfm
Ultimate high: (±1°C) achieved at 16scfm*



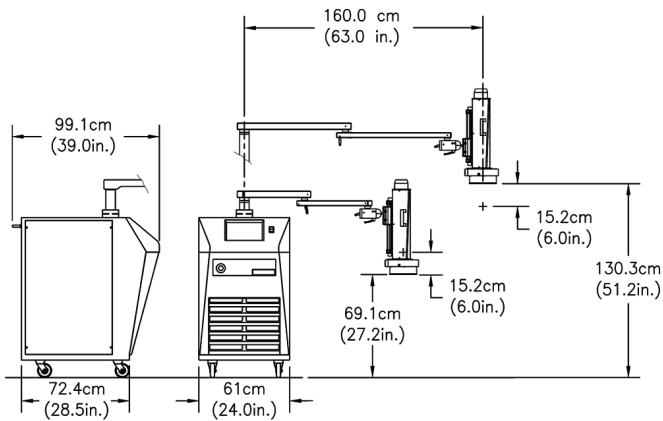

**SYSTEM DIMENSIONS
STANDARD**

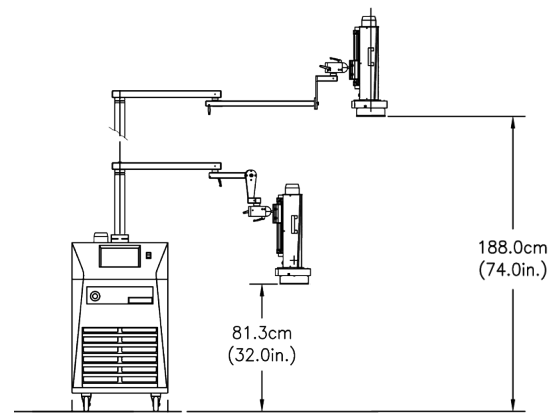

**SYSTEM DIMENSIONS
EXTENDED HEIGHT**

FACILITY REQUIREMENTS

Power ¹	U.S.A. Domestic Voltage Configurations Supported 200 - 250 VAC (230V nominal), 60Hz, 30 amp, 1phase
COMPRESSED AIR²	
Clean, Dry Air (CDA)	Filtered to 5 micron particulate contamination. Oil Content: <0.1 ppm, by weight, filtered to 0.01 micron oil contaminant. Dewpoint: <10°C @ 6.2 BAR (90PSI)
Air Supply Pressure	6.2 to 7.6 BAR (90 to 110 PSIG)
Total Air Flow Rate Required	7.1 to 14.2 l/s (15-30 scfm), 11.8 l/s (25 scfm) nominal
Air Supply Temperature	+20° to +25°C; +22°C nominal
OPERATING ENVIRONMENT²	
Operating Temperature	+20° to +28°C; +23°C nominal
Humidity	0 to 60%; 45% nominal

WEIGHTS & DIMENSIONS

Base ³	Width: 61.0 cm (24 in.), Depth: 72.4 cm (28.5 in.), Height: 108 cm (42.5 in.)
System Weight	Not packed: 236 kg (520 lbs.) Packed: 365 kg (805 lbs.)
Mobility	Four static dissipative, swivel caster wheels
Maximum Reach	160.0cm (63 in.)
Maximum Operating Height	130.3 cm (51.2 in.) Extended height option: 188.0 (74.0 in.)
Minimum Operating Height	69.1 cm (27.2 in.) Extended height option: 81.3 (32.0 in.)
Noise Level	<65dBA

SERVICE & SAFETY

Refrigerants	HCFC and CFC-free, non-toxic, non-flammable
Serviceability	Auto-diagnostics and field replaceable modules
Over Temperature Protection	+305°C (factory set): Operator can set high and low air temperature limits

¹System is configured for operation within voltages listed above using an internal transformer. Please specify power configuration with order

²Under operating conditions which are greater or less than nominal, performance may be less than specification provided

³An additional 20.3cm (8 in.) clearance is required for supply connections and cabinet ventilation

